



TYPICAL

GC20606L18

GC20606-1L18

**Long Arm Double/Single Needle Compound Feed
Heavy Duty Lockstitch Sewing Machine**

OPERATION INSTRUCTION / PARTS MANUAL

CONTENTS

Operation instruction

1. Brief introduction	1
2. Main specifications	1
3. Machine installation and operation preparation	1
1. Machine installation	1-3
2. Operation preparation and notice before running	3-4
4. Machine operation	5-6
1. Coordination among needle, thread and materials	5
2. Install the needle	5
3. Winding the bobbin thread	5-6
5. Machine adjustment	6-9
1. Adjust the needle thread tension and bobbin thread tension	6-7
2. Adjust the pressure of presser foot	7
3. Adjust the safety clutch device	7-9

Parts manual

1. GC2060L18 machine casting components	10-13
2. GC20606-1L18 machine casting components	14-17
3. Upper shaft and presser foot components	18-19
4. Needle bar and lower feed components	20-23
5. Lower shaft thread looping components	24-25
6. Stitch length adjustment components	26-27
7. Knee lifter and winding components	28-29
8. Lubrication components	30-31
9. Accessories	32-33

1. Brief introduction

GC20606L18 machine adopts straight double needle and two vertical auto-lubricating hooks for thread looping, sliding lever for thread take up to form two lines of lockstitch seam. The upper and lower shafts are supported by needle bearing and driven by toothed belt, plunger oil pump lubrication system, compound feed mechanism of feed dog, walking foot and needle, so even if for long stitch length or sewing long materials, it can deal with them freely.

GC20606-1L18 sewing machine adopts single straight needle and vertical auto-lubricating hook for thread looping, it has all of the advantages of GC20606L18.

Both of the models are widely used in the factories of suitcase, tent, cushion, leather goods, apparel, mat, etc.

3. Machine installation

1. Machine installation

1.1 Location of the machine

The machine must be located on the rigid and flat floor for ensuring its smooth operation and reducing its vibration. Meanwhile, a rubber mat should be inserted between the machine stand and the floor for further reducing the running noise.

1.2 Install the oil pan (Fig. 1)

Put the oil pan into the table cutout and place the four cushions on the four corners of the cutout, finally fix the cushion and oil pan on the table by nail.

1.3 Install the machine head (Fig. 2)

Make the hinge A of machine head engaged with hinge socket B on the table, then turn the machine head till it is seated on the frame of table cutout, please keep the turning freely.

2. Main specifications

Model	GC20606L18	GC20606-1L18
Applications	Medium and heavy weight materials	
Max. Sewing speed	1200s.p.m	
Max. Stitch length	9mm	
Needle bar stroke	16mm	
Presser foot lift height	8mm by hand More than 16mm by pedal	
Hook	Large vertical auto-lubricating hook	
Needle	DP×17 Nm125~180	
Needle gauge	6.4mm (standard)	
Lubrication	Auto-lubricating	

Special needle gauge available (mm):3,2,4,4.8,8,9.5,12.7,16,19,25.4.

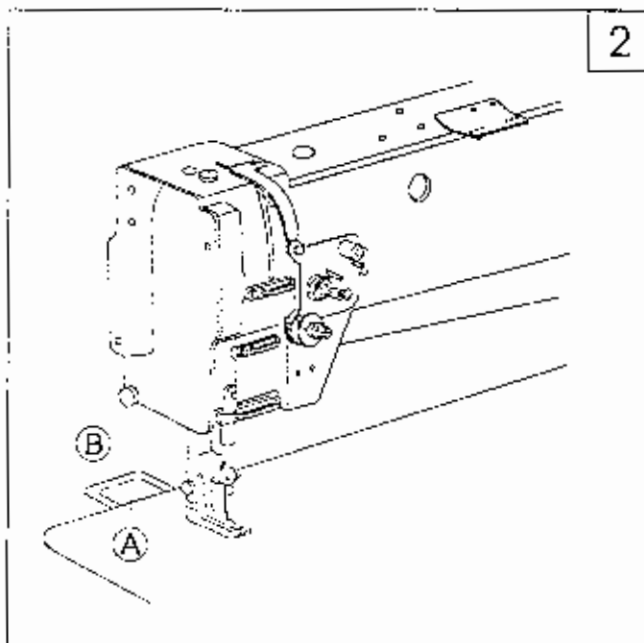
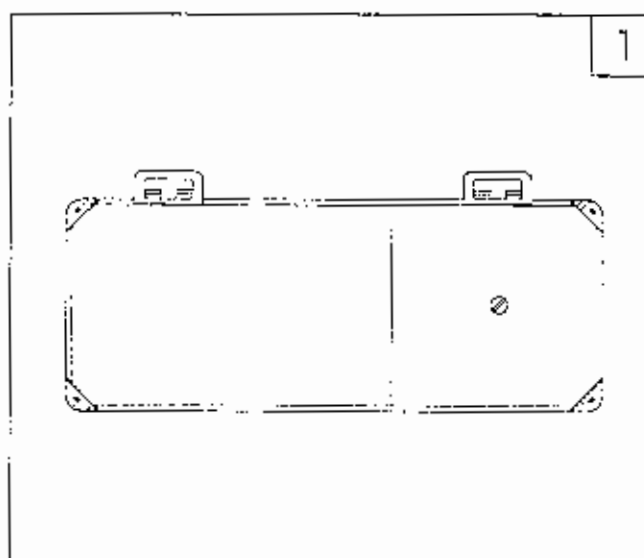

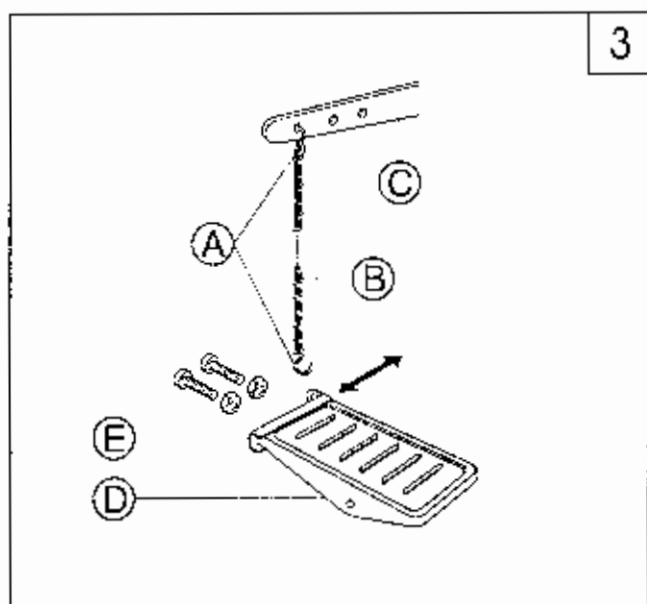

1.4 Install the presser foot lifting controller (Fig. 3)

First connect the chain B with presser foot lift lever C by hooks A, then install the pedal assembly D on the rung of the stand, move the controller E leftward or rightward to make the chain in one line, fix it with bolt and nut, finally connect the hook with the controller E.

(An automatic presser foot lifter is also available, please refer to parts manual Part 7. "Knee lifter and winding components")

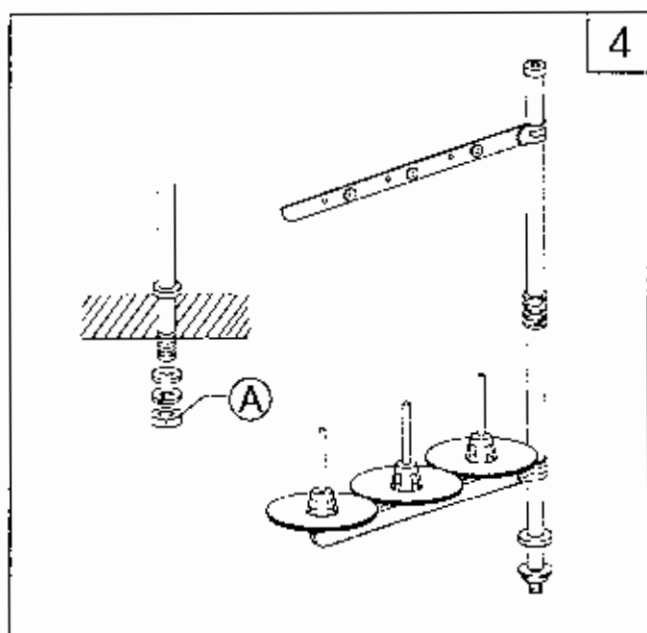

1.5 Install the thread stand (Fig. 4)

The thread stand should be located on the right backside of the table. Threading should be smooth when sewing. When the machine head is turned backward, it should not be touched with the thread stand, then tighten the nut A.

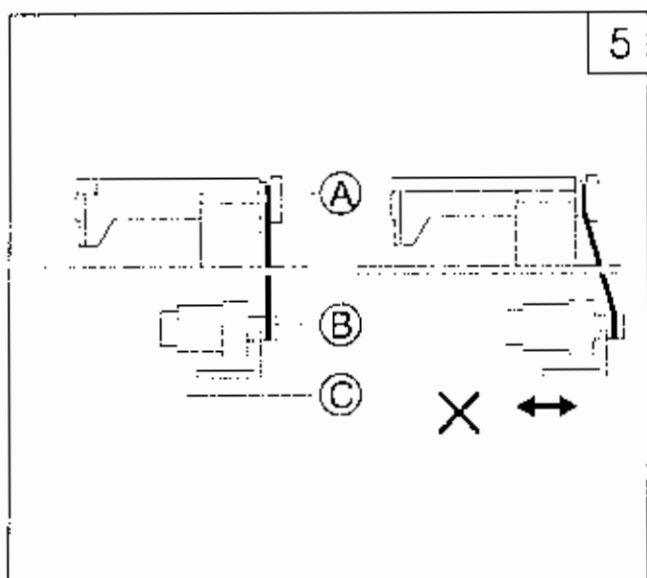

1.6 Install the motor (Fig. 5)

Move the motor C leftward or rightward to make the hand wheel belt groove A and motor pulley belt groove B run in line.

- 1.7 Connecting the clutch lever to the pedal (Fig. 6)
- A. The optimum tilt angle of pedal against floor is approx. 20° ~ 30° .
- B. Adjust the clutch of motor so that the clutch lever C and draw bar B run in line.
- C. The machine hand wheel should rotate counter-clockwise for normal sewing when view from opposite side of balance wheel. The motor should rotate in the same direction. The rotation can be reversed by reversing the plug of motor (turn over 180°)
- D. Adjust the tension of V-belt F by moving the motor up and down. The proper tension of V-belt is a slack of 10 - 12mm when the belt is depressed at the belt span by finger.

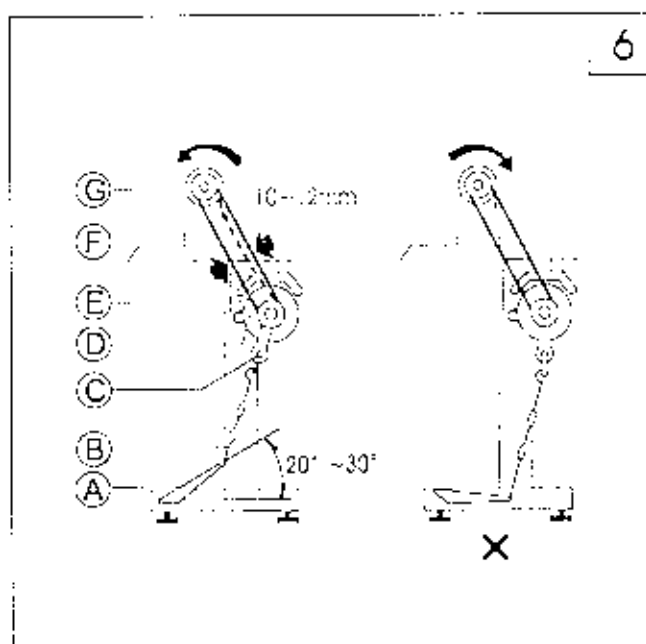

2. Operation preparation and notice before running

2.1 Clearing the machine

Before the head is packed, all of the parts of the machine are coated with anti-rust grease, meanwhile the grease can harden and the dust can cover the machine, surface during long time storage and shipment, so, the dust and grease must be cleared by clean cloth with gasoline.

2.2 Examination

Although every machine is conformed by strict inspection and test before delivery, the parts of the machine may be loose and deformed after long distance transportation with jolt. A thorough examination must be performed. Turn the balance wheel slightly by hand to check if there is running obstruction, parts collision, uneven resistance and abnormal noise. If any of these exist, adjustment must be made accordingly before running.

2.3 Notice before running

A. Oiling (Fig. 7)

Oil amount should be filled according to the marks in the oil pan, Mark A refers to the highest of oil amount; Mark B refers to the lowest, be careful that the oil amount should not be lower than Mark B, otherwise the machine parts can not be fed with oil and cause overheat and collision.

Please be sure to use machine oil 18# or HJ-7.

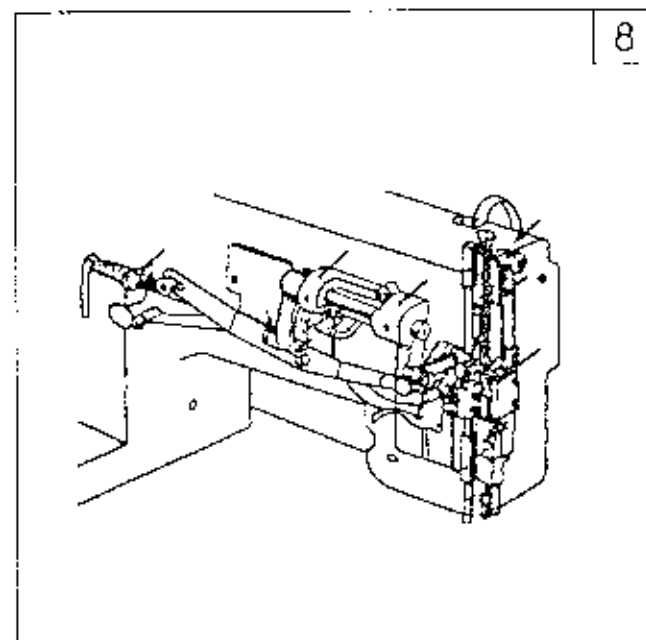
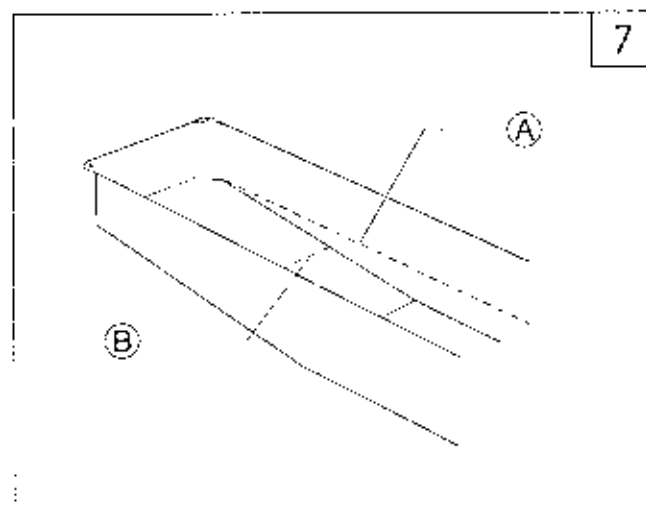

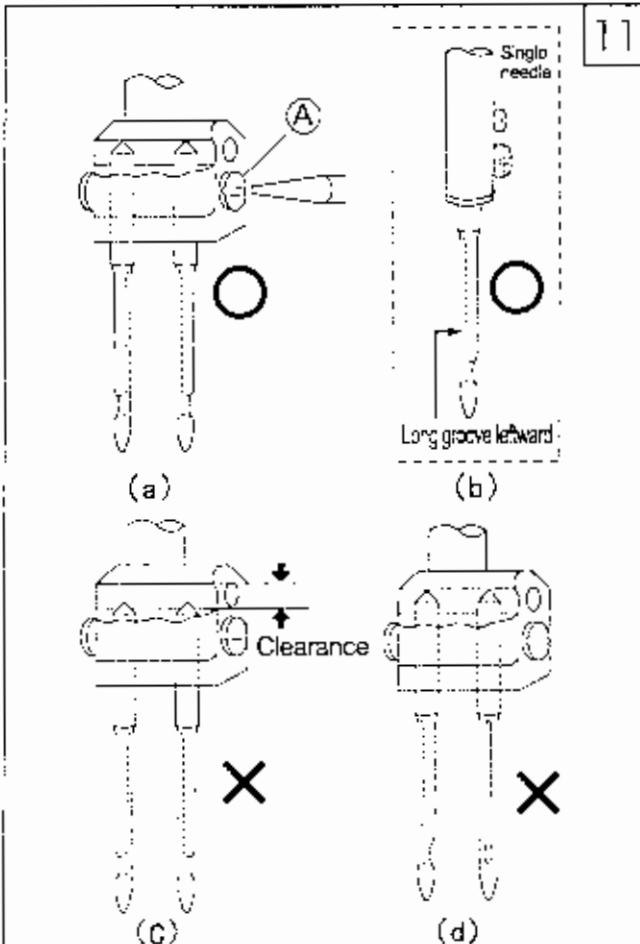
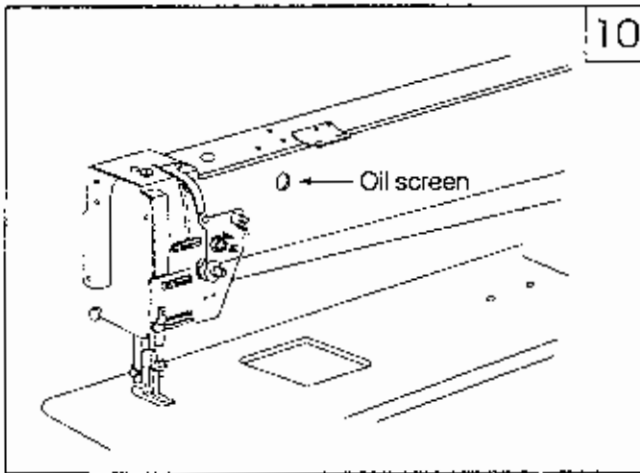
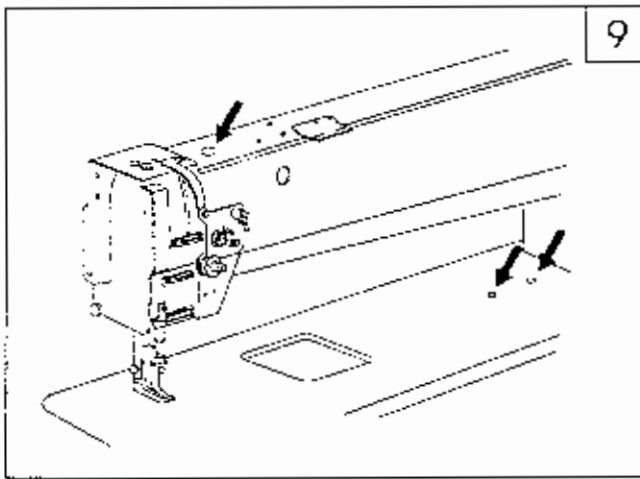

B. When the machine starts for initial time or reuse after a long time, the proper oil amount should be filled in the sections of machine shown by arrows in Fig. 8,9. When it is in operation, please observe the oil sparking in oil screen to check the oil condition.

C. When a new machine starts running, for extending its life, please run at a medium and low speed (1000s.p.m) for about 2 month and then raise the speed gradually.

D. Please turn off the power when it is not in use or the operator leaves away from it.

E. Replace the oil every month, when replacing, fully drain off the old oil in the oil pan and add the new one.

F. For GC20606L18, the needle gauge options are: 6.4, 3.2,4,4.8,8,9.5,12,7,16,19,24.5mm. To get it, the needle plate, inner and outer presser foot, needle holder, feed dog, left and right sliding plate, thread guide should be changed, the standard needle gauge is 6.4mm, for the other needle gauge, the relevant parts can be ordered from the factory.

4. Machine operation

1. Coordination among needle, thread and materials

Please use needle DP x 17 or 135 ~ 17, Nm125 ~ 180, the coarseness of needle should be in accordance with the nature of materials. If stitching on heavy weight materials with a slim needle, the needle will be broken easily. Needle skipping or thread breakage will also occur. On the contrary, stitch on tightly materials with a very coarse needle, the materials will be destroyed because of over-big needle hole, so the needle and thread should be properly selected.

2. Install the needle (Fig. 11)

Turn the hand wheel to lift the needle bar to its highest position, loosen the needle set screw A, fully insert the needle shank up to the bottom of needle holder, keep the long grooves of the two needles opposite with each other, then tighten the set screw as shown in Fig.(a), For single needle, keep the long groove of needle facing the left of the operator as shown in Fig.(b).

Note: Fig.(c) insufficient insertion or Fig. (d) wrong direction of needle groove is incorrect.

3. Winding the bobbin thread

3.1 The method of winding

Insert the bobbin B into winder shaft, threading the thread A to upper and lower holes of pin E, then to thread tension disc F, draw the thread up and wind thread several circles around bobbin B, put the winding lever D into bobbin B, then it can automatic winding when sewing. (If only winding, not sewing, please lift the presser foot.)

Please don't overfill the bobbin thread, otherwise the thread will loosen down from the bobbin. The optimum capacity of bobbin thread is fill about 80% of bobbin outside diameter, and this can be adjusted by screw D. After finish, thread can be cut by thread cutter shown in Fig. 12. Wind the thread A several circles around cutter C, draw the thread and the thread is cut.

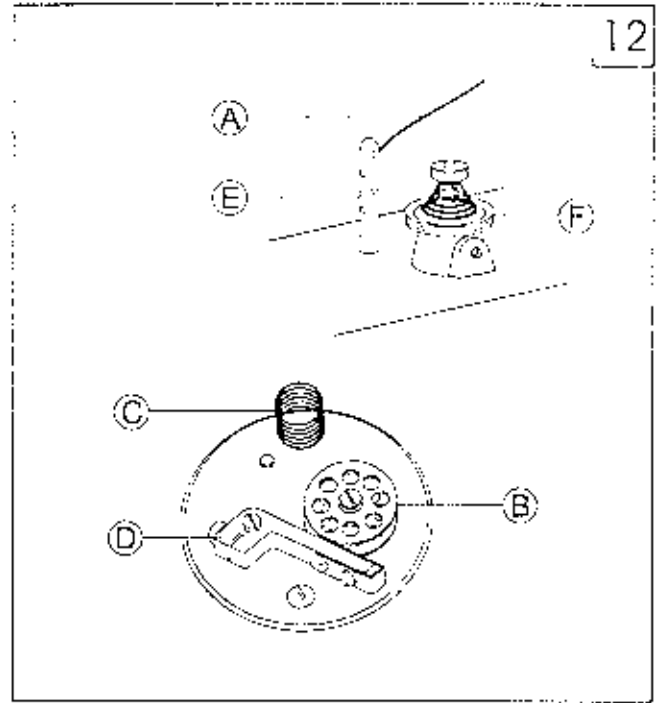

3.2 Threading (Fig. 13)

A. Every thread should be drawn through thread hole A, when using light and smooth thread (polyester or long silk thread), it should be drawn through thread hole B.

B. Keep the thread take-up lever at its highest position, threading the needle thread in the following numerical order.

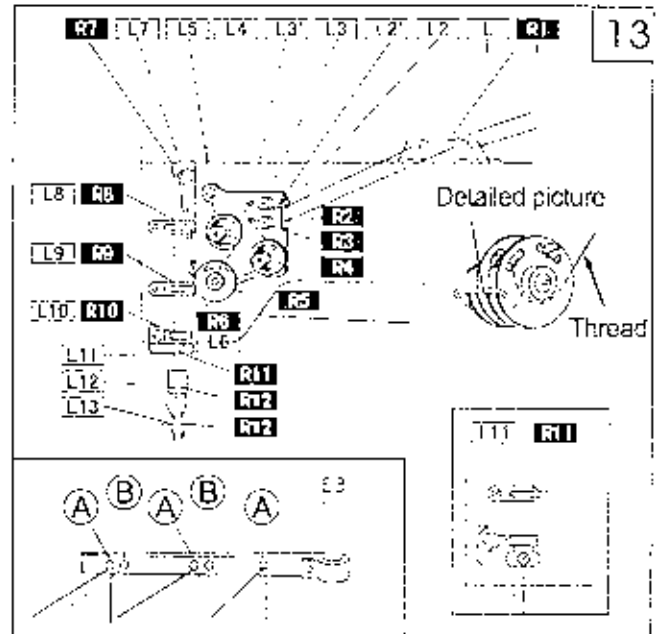

3.3 Stitch length (Fig.14)

The stitch length can be regulated by stitch length dial A. Turn it counter-clockwise to expand its length and clockwise to shorten its length. The numbers on dial show the sizes of the stitch length in mm.

For reverse feed, press down feed lever B to perform reverse sewing. Release the lever, the feed lever can reset automatic and the forward sewing is resumed.

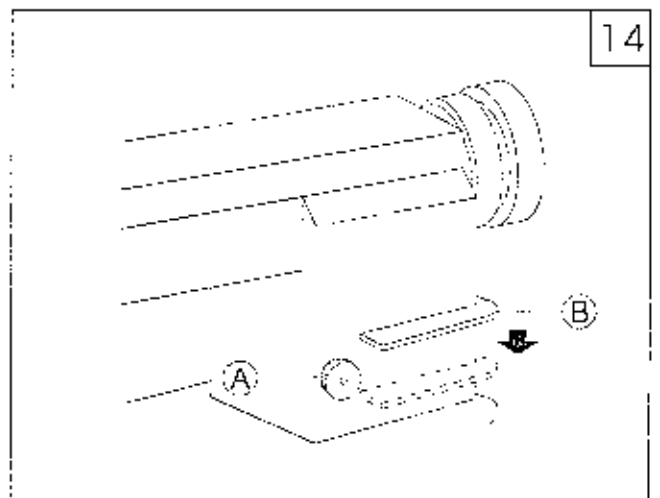

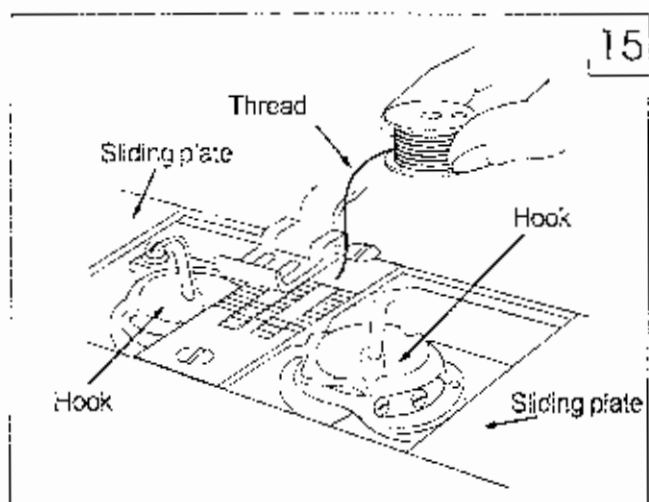

3.4 Placing bobbin (Fig. 15)

Note: when bobbin is placed into the bobbin case, the thread should be wound properly in the correct direction shown in the figure.

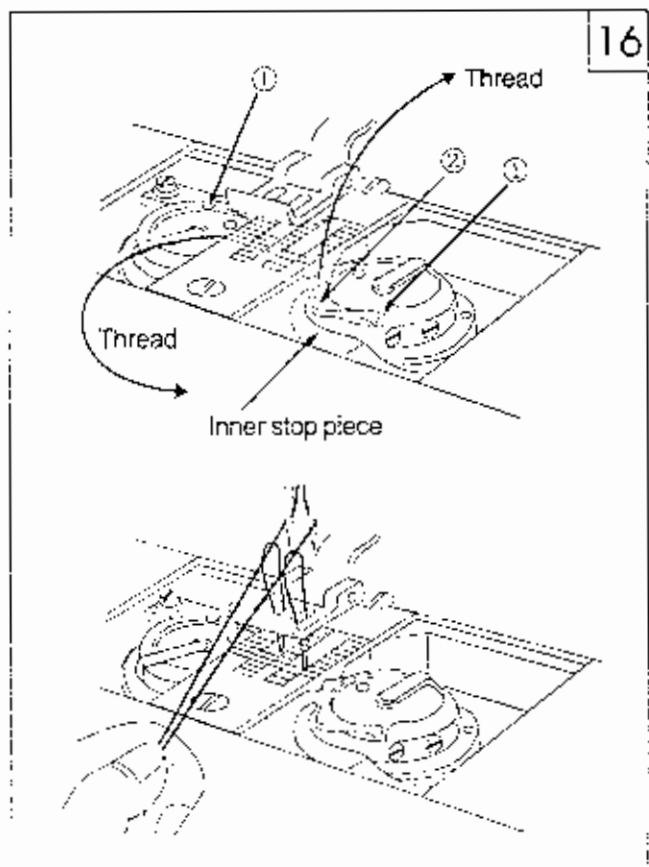

3.5 Drawing thread from the bobbin (Fig. 16)

A. Draw the thread end to bobbin slot ① shown in the figure, and pull it out down through the inner bobbin stop piece.

B. Hold the thread end with left hand, turn the hand wheel slowly and get the bobbin thread, then draw them a little apart from the presser foot.



5. Machine adjustment

1. Adjust the needle thread tension and bobbin thread tension

All forms of stitches are shown in Fig. 20

The normal stitch of sewing machine is shown in Fig. 17A. If stitch is abnormal, the puckering and thread breakage will occur, the needle thread tension and bobbin thread tension should be adjusted so that the normal stitch can be obtained.

A. If the stitch seam shows as Fig. 17B, indicates that the needle thread tension is too tight or the bobbin thread tension is too loose. Please turn the thread tension nut counter-clockwise to release the needle thread pressure; or turn the bobbin lace adjusting screw with a screwdriver to increase the bobbin thread tension. (See Fig. 18,19)

B. If the needle thread tension is too loose or the bobbin thread tension is too tight shown as Fig. 17C. Please turn the thread tension nut clockwise to increase the needle thread pressure; or turn the bobbin lace adjusting screw with a screwdriver to decrease the bobbin thread tension. (See Fig. 18,19)

For special sewing with special thread, the tension needed can be obtained by adjusting the power and stroke of the thread take-up spring.

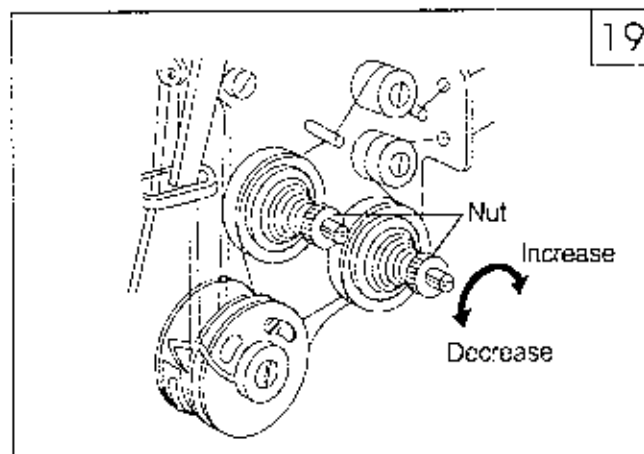
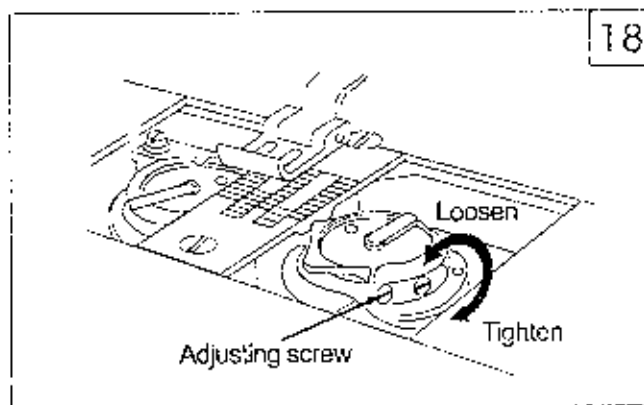

2. Adjust the pressure of presser foot (Fig.20)

The pressure of presser foot should be adjusted according to the thickness of the sewing materials. If stitch on heavy weight materials, the pressure should be increased by turning the pressure adjusting screw on the back of machine head clockwise, on the contrary, turn it counter-clockwise.

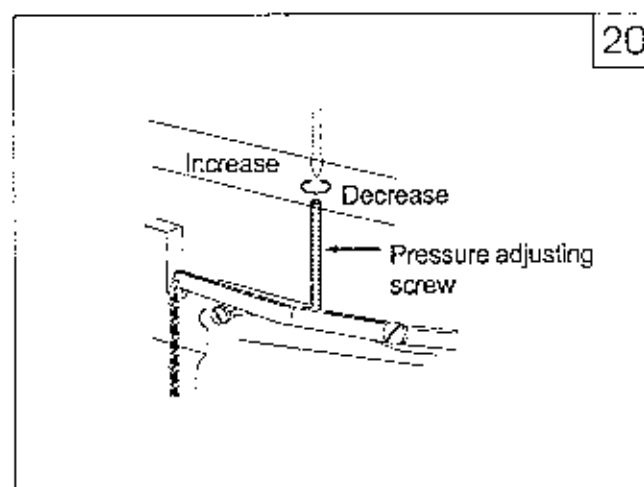

3. Adjust the safety clutch device

The function of safety clutch device is to prevent the hook and toothed belt from being damaged when the needle thread is drawn into the hook for abnormal load during the operation.

3.1 The function of safety clutch device (Fig.21)

A. When the safety clutch is functioning, the toothed belt will remove the load and the hook shaft will stop rotating, only the upper shaft still rotates, and the machine stops work.

B. Clean off the needle thread which is draw into the hook.

C. Turn the toothed belt shaft by hand to check if the hook shaft can turn smoothly, then reset the safety clutch device.

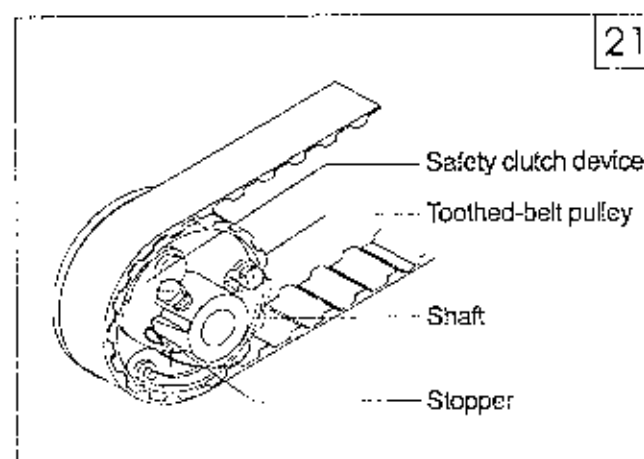

22

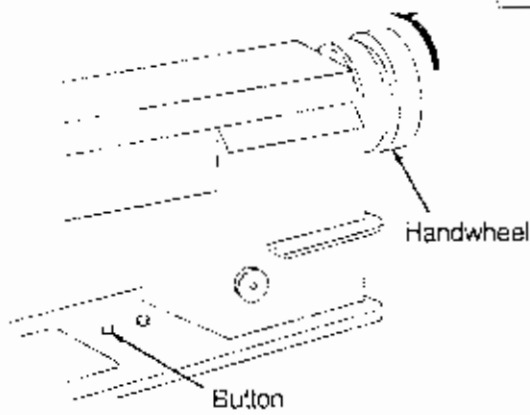

3.2 How to reset the safety clutch device (Fig.22)

- A. While press down the button on the bed surface with left hand, turn the hand wheel slowly with right hand in the direction shown in Fig. 22 (clockwise).
- B. When the stopper brakes the hand wheel, more strength is needed to turn the balance wheel to reset the safety clutch device.
- C. Release the button.
- D. So the resetting is OK and put the bobbin into hook. (See Fig.15)

23

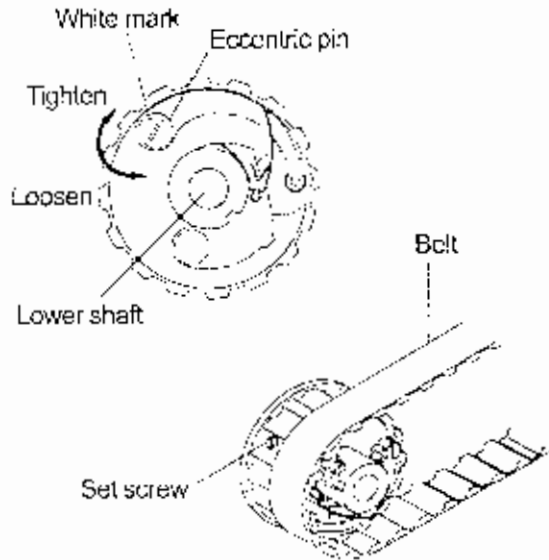

3.3 How to adjust the strength on the safety clutch device (Fig.23)

- A. When the white mark of the eccentric pin aims at the centre of the lower shaft, indicates that the strength on the safety clutch is the minimum. When the white mark points outward, the strength is properly increased.
- B. For adjusting the strength of it, move the belt and loosen the set screw of eccentric pin, and turn the eccentric pin.
- C. After adjustment, please tighten the set screw.

24

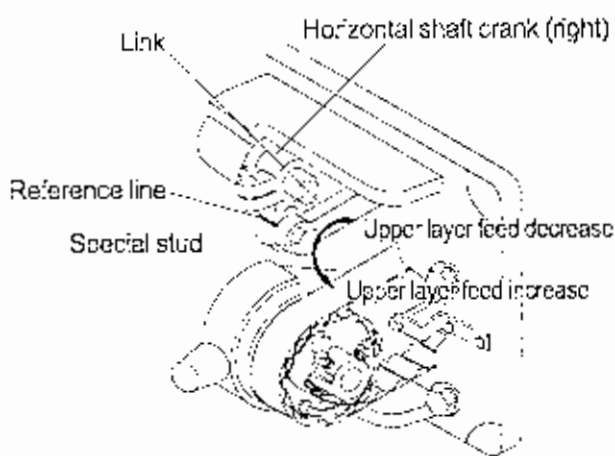

3.4 Adjust the upper feed mechanism (Fig.23)

If the upper and lower feed are not in timing during sewing, the long hole of the horizontal feed crank(right) should be adjusted to get the length of upper feed.

Adjusting as follows:

- A. Loosen the special stud.
- B. Move the stud upward to decrease the amount of upper feed.
- C. Move the stud downward to increase the amount of upper feed. Theoretically, when it is on the reference line of the horizontal feed crank, the upper feed amount equals to the lower feed amount.
- D. After adjustment, tighten the special stud.

3.5 Adjust the vertical stroke of presser foot (Fig. 25)
When stitch on the very elastic materials or the thickness of sewing materials changes, the adjustment should be done in the following order:

A. Loosen the special stud.

B. When the central line distance between the special stud and the presser foot lifting rear crank becomes shorter, the vertical stroke of presser foot will become longer, on the contrary, the distance becomes longer, the stroke will become shorter.

C. After adjustment, tighten the special stud. The common vertical stroke of presser foot can be adjusted within the range of 2 ~ 6mm.

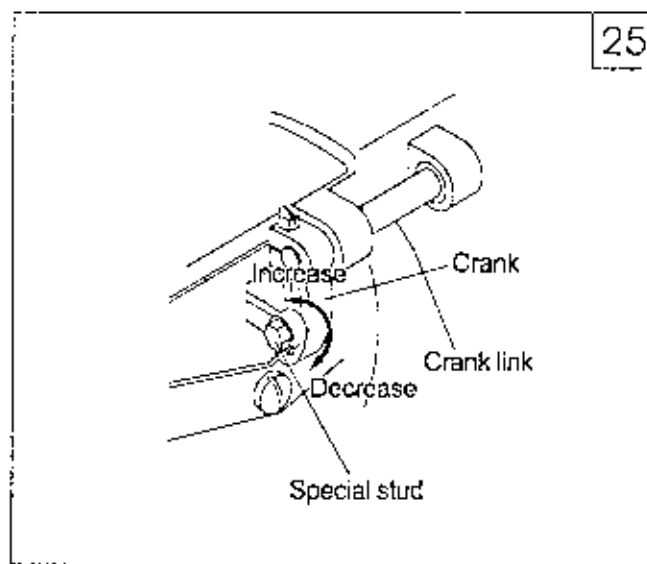

3.6 Adjust the hook oil amount (Fig. 26)

It adopts plunger full auto-lubricating system, even at a very low speed, it still can supply and suck oil very well. Generally, only the hook oil amount can be adjusted, the others cannot be adjusted. The hook oil amount can be controlled by the oil amount adjusting screw. First loosen the nut of adjusting screw, turn the screw clockwise to increase the oil amount, on the contrary, decrease the oil amount. After adjustment, tighten the nut.

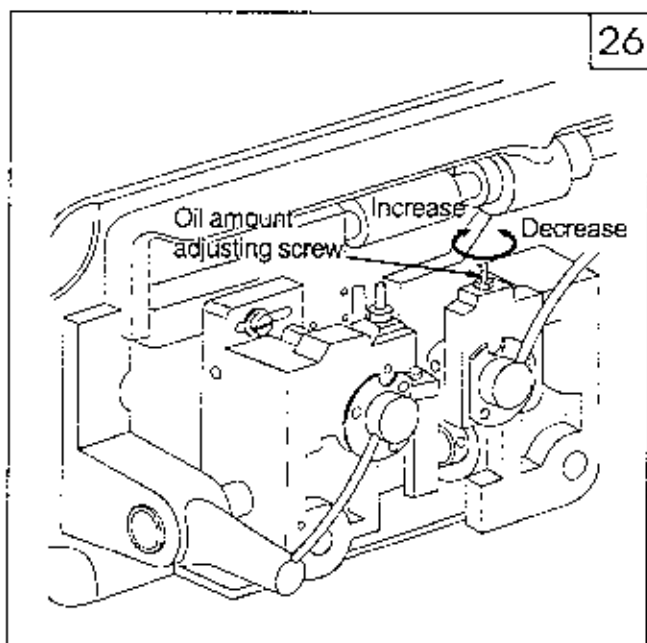

Parts manual

1.GC20606L18 machine casting components

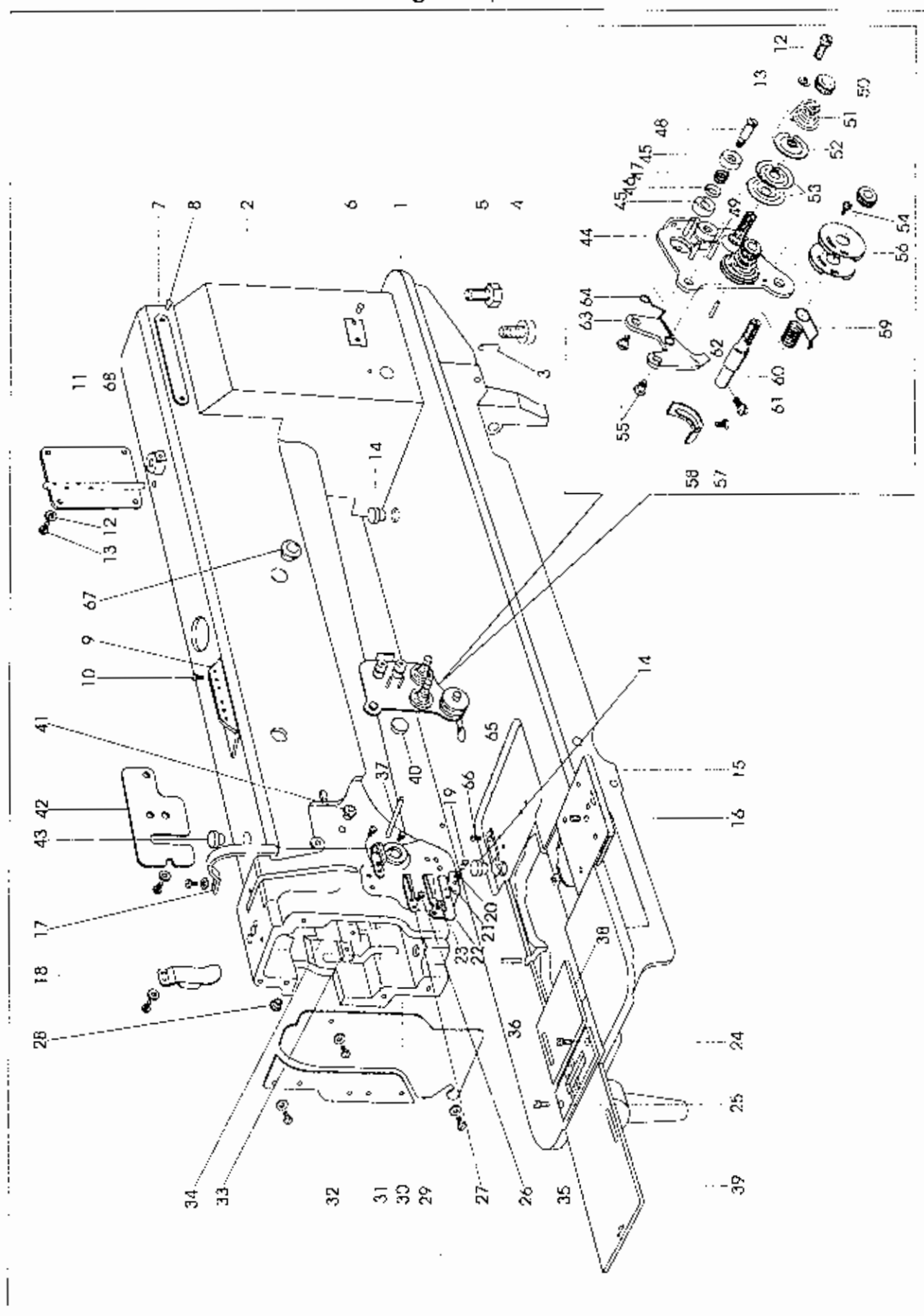

1.GC20606L18 machine casting components

No.	Part number	Name	Qt.	Remark
1	43WF1-001	Machine bed	1	
2	43WF1-002	Machine arm	1	
3		Pin	2	A6×30 GB117-86
4		Screw	1	M10×35 GB70-85
5		Screw	3	M10×35 GB5781-85
6	43WF1-003B	Model label	1	
7	43WF1-004B	Brand label	1	
8		Rivet	4	φ2.5×5 GB827-86
9	1WF1-015	Upper thread guide	1	
10	1WF1-016	Screw	2	SM11/64"×40/8
11	1WF1-017	Back cover	1	
12	1WF1-011	Screw	15	SM11/64"×40/9
13	22T1-007	Washer	15	
14	1WF1-032	Cover	2	PE
15	1WF1-038	Front slide plate	1	
16	1WF1-039	Screw	1	SM11/64"×32/5.4
17	1WF1-019	Thread take-up lever cover	1	
18	1WF1-030	Back front cover	1	
19	1WF1-027	Screw	1	
20	1WF1-028	Spring	1	
21	1WF1-003	Thread retainer	1	
22	1WF1-004	Lower thread finger	1	
23	1WF1-005	Screw	1	SM9/64"×40/6.5
24	1WF1-034	Screw	1	
25	1WF1-036	Screw	1	SM11/64"×40
26	1WF1-007	Screw	1	SM9/64"×40
27	1WF1-006	Middle thread finger	1	
28	1WF1-018	Rubber plug (φ8.5)	2	
29	1WF1-013	Face plate	1	
30	1WF1-009	Screw	2	SM3/16"×28
31	1WF1-008	Upper thread finger	1	
32	1WF1-012	Guide set plate	1	
33	1WF1-021	Oil stopper set plate	1	
34	1WF1-020	Oil stopper	1	
35	1WF1-035	Needle plate	1	
36	1WF1-037	Pin shaft	1	
37	1WF1-023	Thread releasing lever	1	
38	1WF1-033	Right sliding plate	1	
39	1WF1-040	Left sliding plate	1	
40	1WF1-029	Rubber plug (φ14.5)	1	
41	1WF1-022	Rubber plug (φ12.7)	1	
42	1WF1-031	Back fitting cover	1	
43	1WF1-014	Rubber plug (φ12.7)	1	

1.GC20606L18 machine casting components

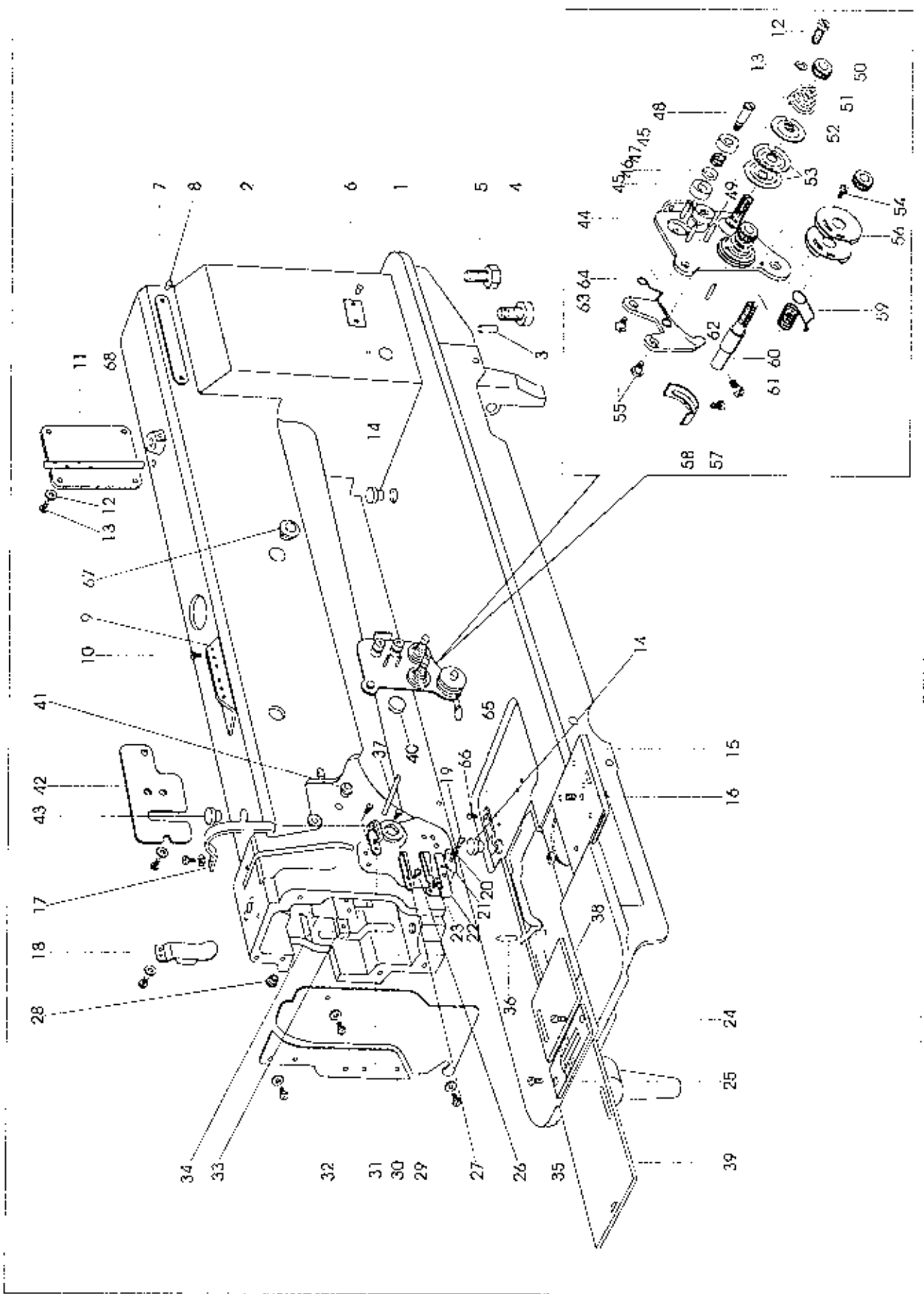

1.GC20606L18 machine casting components

No.	Part number	Name	Qt.	Remark
44	1WF1-010A	Thread tension fixing bracket assembly	1	
45	1WF1-010B	Thread guide bracket	2	
46	1WF1-010C	Thread guide plate	2	
47	1WF1-010D	Spring	2	
48	1WF1-010E	Thread guide bracket screw assembly	2	
49	1WF1-010M	Thread releasing pin (short)	1	
50	1WF1-010H	Thread tension nut	3	
51	1WF1-010G	Thread tension spring	2	
52	1WF1-010S	Thread releasing disc	2	
53	1WF1-010F	Thread tension disc	4	
54	1WF1-010R	Screw	1	
55	1WF1-010Q	Screw	2	
56	1WF1-010J	Thread controlling disc assembly	2	
57	1WF1-026	Screw	1	SM9/64"X40/4.5
58	1WF1-025	Stop plate	1	
59	1WF1-010K	Thread take-up spring	1	
60	1WF1-010I	Thread take-up spring shaft	1	
61	1WF1-024	Screw	1	SM/64"X40/4.5
62	1WF1-010L	Thread releasing pin (long)	1	
63	1WF1-010W	Thread tension retaining plate	1	
64	1WF1-010P	Thread releasing spring	1	
65	1WF1-043	Spring retaining plate	1	
66	22T2-004	Screw	1	
67	43WF1-006	Rubber plug	1	
68	35WF1-006	Thread guide pin	1	

2.GC20606-1L18 machine casting components

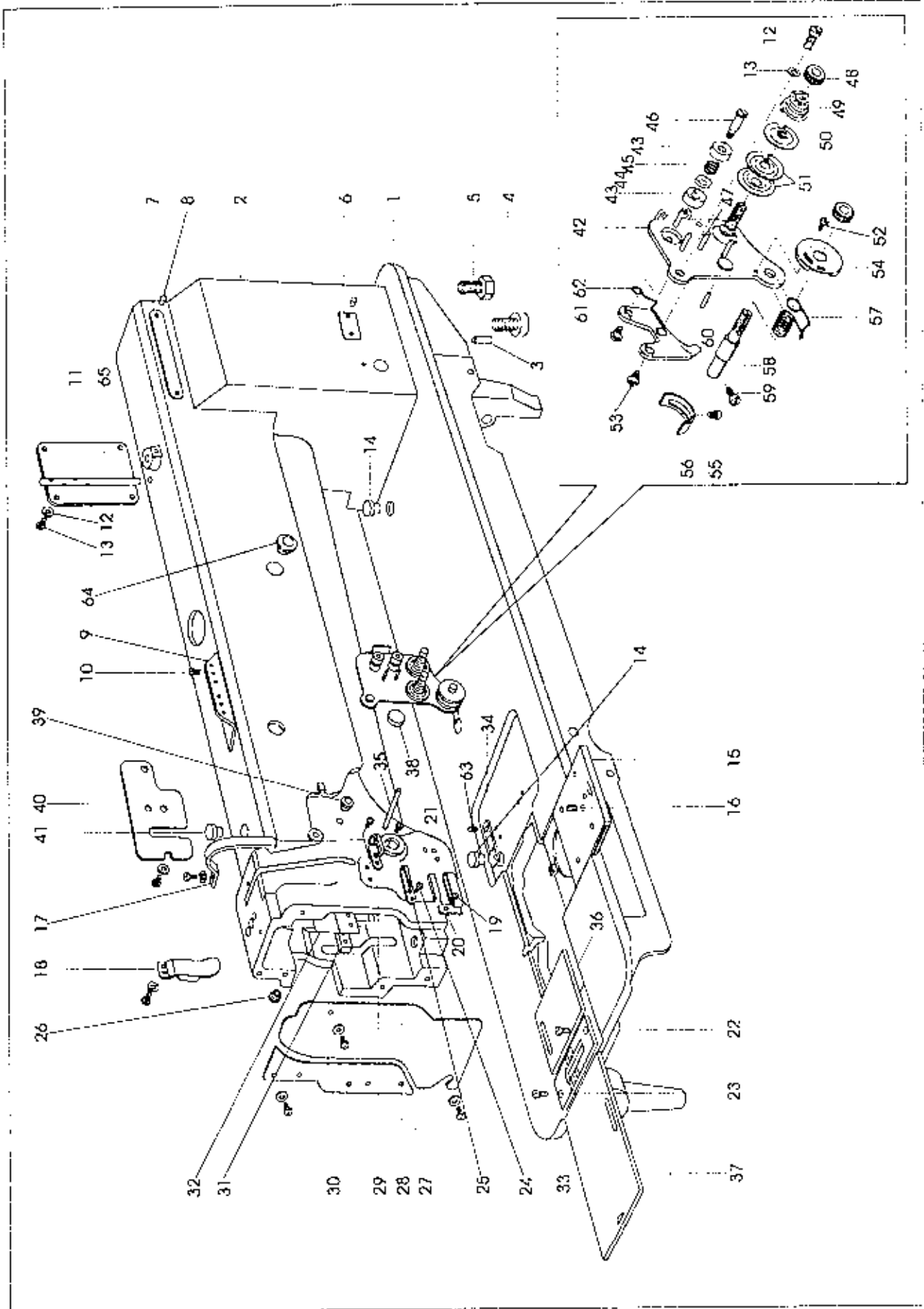

2.GC0602-1L18 machine casting components

No.	Part number	Name	Qt.	Remark
1	44WF1-003	Machine bed	1	
2	43WF1-002	Machine arm	1	
3		Pin	2	A6×30 GB117-86
4		Screw	1	M10×35 GB70-85
5		Screw	3	M10×35 GB5781-85
6	44WF1-002	Model label	1	
7	44WF1-005	Brand label	1	
8		Rivet	4	φ2.5×5 GB827-86
9	1WF1-015	Upper thread guide	1	
10	1WF1-016	Screw	2	SM11/64"×40/8
11	1WF1-017	Back cover	1	
12	1WF1-011	Screw	15	SM11/64"×40/9
13	22T1-007	Washer	15	
14	1WF1-032	Cover	2	PE
15	1WF1-038	Front slide plate	1	
16	1WF1-039	Screw	1	SM11/64"×32/5.4
17	1WF1-019	Thread take-up lever cover	1	
18	1WF1-030	Back front cover	1	
19	1WF1-005	Screw	1	
20	9WF1-001	Lower thread finger	1	
21	9WF1-002	Oil felt	1	
22	1WF1-034	Screw	1	
23	1WF1-036	Screw	1	
24	1WF1-007	Screw	1	
25	1WF1-006	middle thread finger	1	
26	1WF1-018	Rubber plug (φ8.5)	1	
27	1WF1-013	Face plate	1	
28	1WF1-009	Screw	2	SM3/16"×28
29	1WF1-008	Upper thread finger	1	
30	1WF1-012	Guide set plate	1	
31	1WF1-021	Oil stopper set plate	1	
32	1WF1-020	Oil stopper	1	
33	9WF1-004A	Needle plate	1	
34	1WF1-043	Right sliding plate spring retainer	1	
35	1WF1-023	Thread releasing lever	1	
36	1WF1-033	Right sliding plate	1	
37	1WF1-040	Left sliding plate	1	
38	1WF1-029	Rubber plug (φ14.5)	1	
39	1WF1-022	Rubber plug (φ12.7)	1	
40	1WF1-031	Back fitting cover	1	
41	1WF1-034	Rubber plug (φ12.7)	1	

2.GC0602-1L18 machine casting components

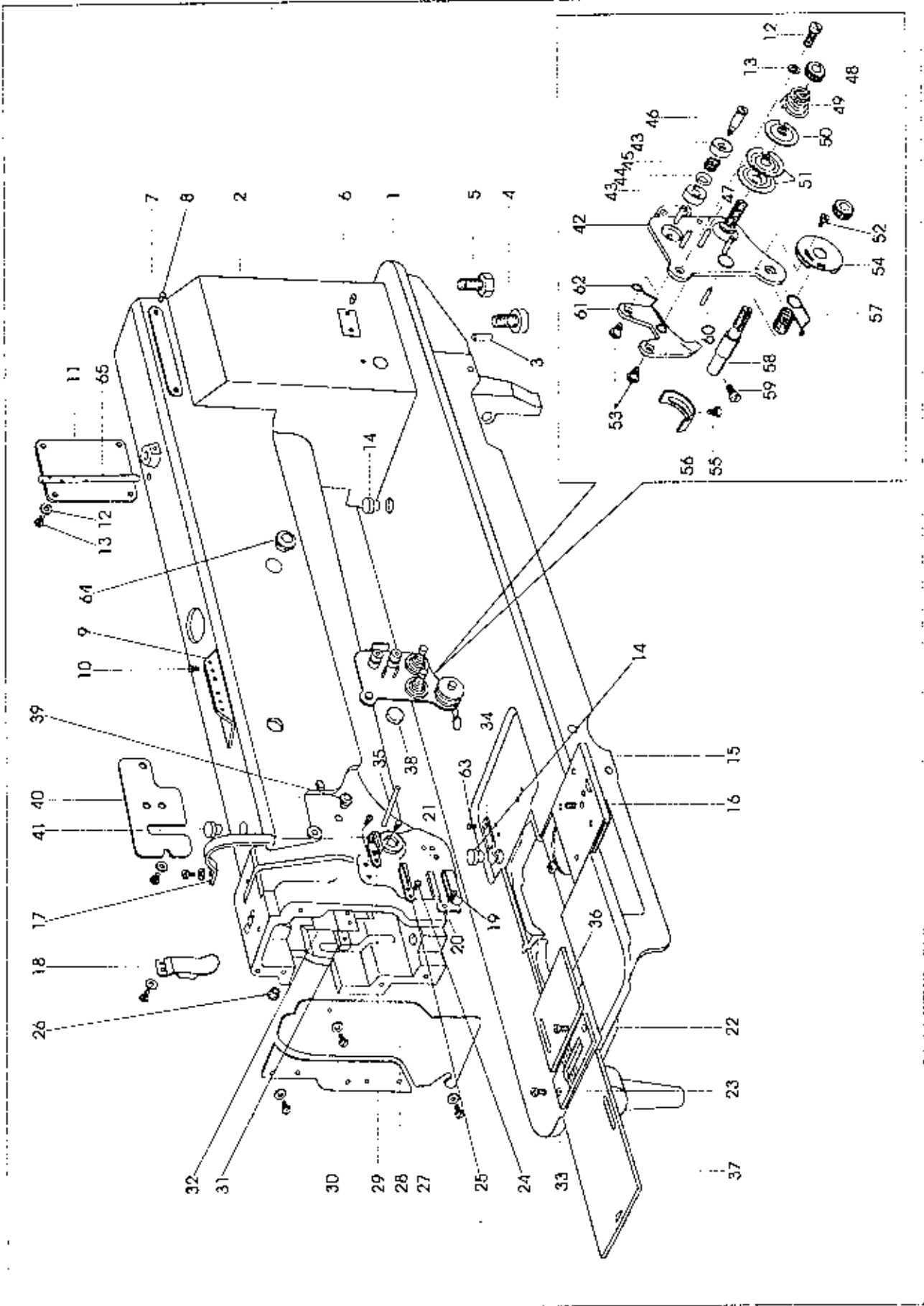

2.GC0602-1L18 machine casting components

No.	Part number	Name	Qt.	Remark
42	1WF1-010A	Thread tension fixing bracket assembly	1	
43	1WF1-010B	Thread guide bracket	1	
44	1WF1-010C	Thread guide plate	1	
45	1WF1-010D	Spring	1	
46	1WF1-010E	Thread guide bracket screw assembly	1	
47	1WF1-010M	Thread releasing pin (short)	1	
48	1WF1-010H	Thread tension nut	1	
49	1WF1-010G	Thread tension spring	1	
50	1WF1-010S	Thread releasing disc	1	
51	1WF1-010F	Thread tension disc	2	
52	1WF1-010R	Screw	1	
53	1WF1-010Q	Screw	2	
54	1WF1-010J	Thread controlling disc assembly	1	
55	1WF1-026	Screw	1	SM9/64"×40/4.5
56	1WF1-025	Stop plate	1	
57	1WF1-010K	Thread take-up spring	1	
58	1WF1-003A	Thread take-up spring shaft	1	
59	1WF1-024	Screw	1	SM/64"×40/4.5
60	1WF1-010I	Thread releasing pin (long)	1	
61	1WF1-010W	Thread tension retaining plate	1	
62	1WF1-010P	Thread releasing spring	1	
63	22T2-004	Screw	1	
64	43WF1-006	Rubber plug	1	
65	35WF1-006	Thread guide pin	1	

3. Upper shaft and presser foot components

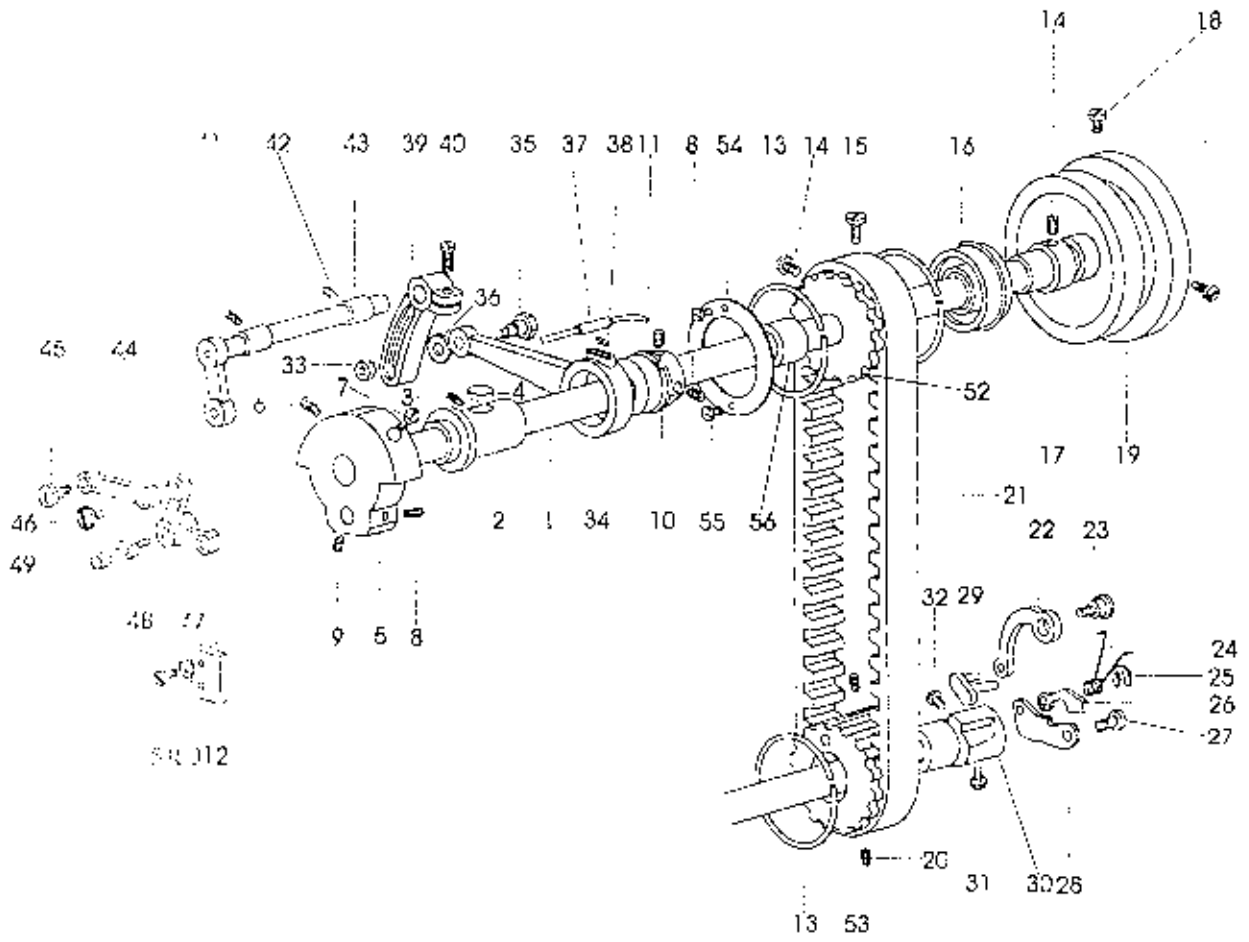

3. Upper shaft and presser foot components

No.	Part number	Name	Qt.	Remark
1	43WF2-001	Upper shaft	1	
2	1WF2-022	Upper shaft bushing (front)	1	
3	1WF2-023	Screw	1	SM1/4"×24/13
4	1WF2-024	Oil felt	1	Wool felt
5	1WF2-021	Needle crank	1	
6	1WF2-020	Screw	1	SM9/32"×28
7	1WF2-007	Screw	1	Interchangeable with GB7-1
8	1WF2-010	Screw	3	SM1/4"×40/7
9	1WF2-009	Screw	1	SM1/4"×40/4
10	1WF5-026	Eccentric cam	1	
11		Stop ring	1	φ25 GB894.1-86
12	1WF5-041	Slot for front crank sliding block	1	
13	1WF2-026	Stop ring	3	
14	1WF2-030	Screw	3	SM15/64"×28/8.5
15	1WF2-029	Screw	1	SM15/64"×28/15
16		Ball bearing	1	
17	1WF2-031	Upper shaft bushing (rear)	1	
18	1WF2-019	Screw	2	SM15/64"×28/12
19	1WF2-032	Hand wheel	1	
20	1WF2-044	Screw	2	SM15/64"×28/4.5
21	1WF2-028	Toothed belt	1	
22	1WF2-039	Spring plate	1	
23	1WF2-037	Pin	1	
24	1WF2-041	Spring	1	
25		Split stop ring	1	φ3 GB896-86
26	1WF2-040	Stop plate	1	
27	1WF2-048	Nail	1	
28	1WF2-045	Braking plate	1	
29	1WF2-042	Connector	1	
30	1WF2-046	Bushing	1	
31	1WF2-047	Screw	1	SM15/64"×28/10.5
32	1WF2-038	Screw	1	SM15/64"×28/10
33	1WF5-001	Nut	1	
34	1WF5-025	Link lever	1	
35	1WF5-044	Bolt	1	
36		Washer	1	Washer 6 GB95-85
37	1WF5-023	Oil pipe assembly	1	
38	1WF5-024	Spring	1	
39	1WF5-045	Presser foot lifting crank (rear)	1	
40	1WF4-018	Screw	3	SM1/4"×24/16
41	1WF5-038	Presser foot lifting crank (front)	1	
42	1WF5-028	Screw	2	SM1/4"×24/8
43	1WF5-037	Bushing	2	
44	1WF5-030	Link lever	1	
45	1WF5-029	Screw	1	
46	1WF5-032	Screw	1	SM11/64"×40/6
47	1WF5-033	Presser foot lifting movable plate	1	
48	1WF5-034	Rolling ball shaft	1	
49	1WF5-035	Rolling ball	1	
50		Washer	2	Washer 4 GB848-85
51	1WF5-042	Screw	2	SM11/64"×40/10
52	1WF2-027	Upper shaft timing pulley	1	
53	1WF2-037	Lower shaft timing pulley	1	
54	43WF3-004	Bobbin winding shaft	1	
55	JO.0.40	Screw	2	
56	43WF2-003	Upper shaft bushing (middle)	1	

4. Needle bar and lower feed components

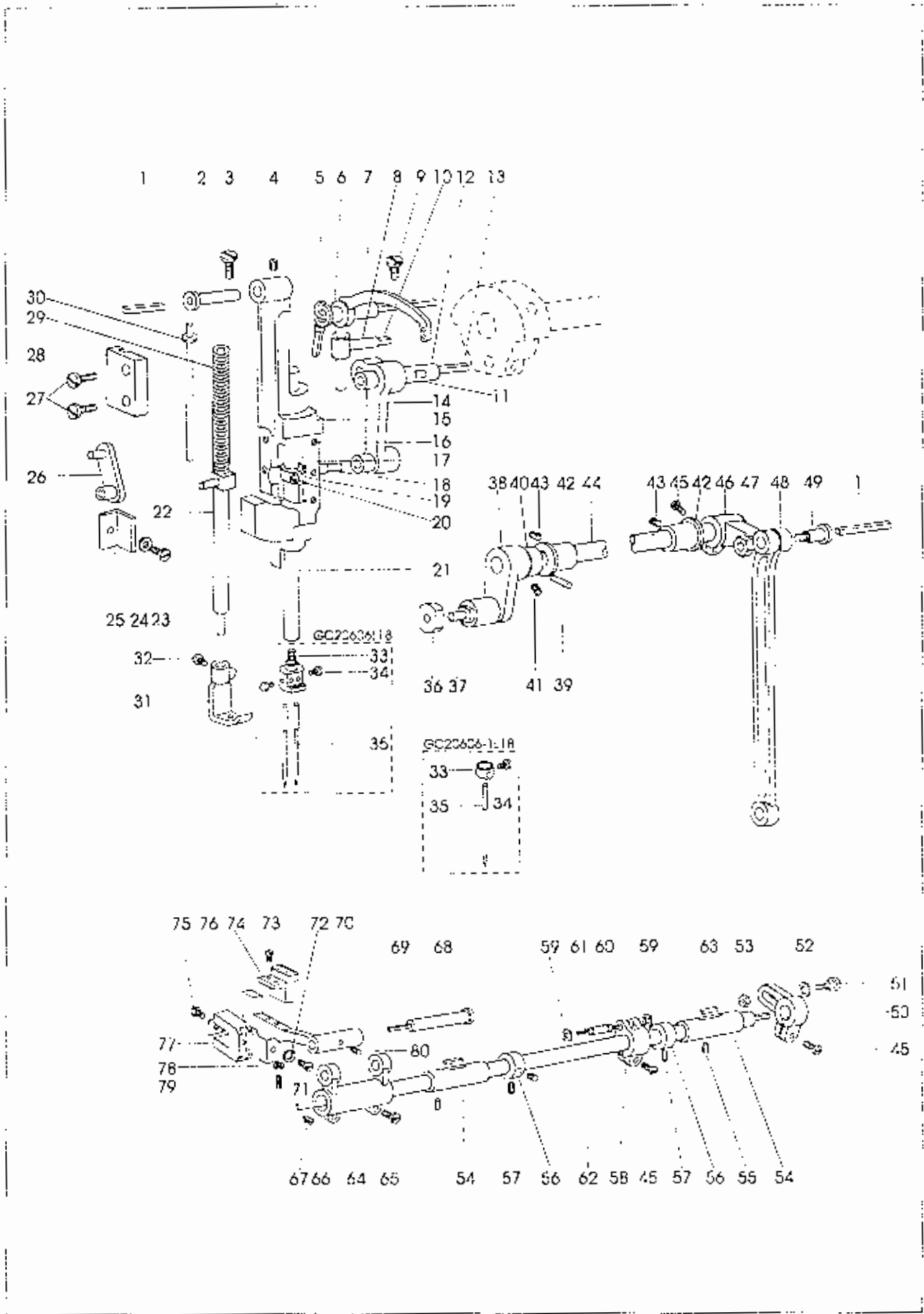

4. Needle bar and lower feed components

No.	Part number	Name	Qt.	Remark
1	1WF5-017	Oil wick	1	$\phi 2.5 \times 80$ cotton thread
2	1WF5-018	Shaft for needle bar rocking frame	1	
3	1WF5-031	Screw	1	SM5/16" \times 28/10
4	1WF5-019	Screw	1	SM15/64" \times 28/8
5	1WF2-018	Oil wick	1	$\phi 2.5 \times 240$ cotton thread
6	1WF2-017	Bushing	1	
7	1WF2-016	Thread take-up lever	1	
8	1WF2-011	Thread take-up lever sliding block	1	
9	1WF2-019	Screw	1	SM15/64" \times 28/12
10	1WF2-012	Oil wick	1	$\phi 3 \times 25$
11	1WF2-013	Plug	1	
12	1WF2-014	Needle bar crank pin	1	
13	1WF2-015	Oil wick	1	$\phi 3 \times 80$ cotton thread
14	1WF2-008	Needle bar link	1	
15	1WF5-011	Needle bar rocking frame	1	
16	1WF5-013	Screw	6	SM3/32" \times 56/4.6
17	1WF5-012	Shim needle bar rocking frame	2	
18	1WF2-007	Oil felt	1	
19	1WF2-005	Needle bar connector	1	
20	1WF2-006	Screw	1	SM9/64" \times 40/8.5
21	1WF2-004	Needle bar	1	(GC20606L18)
	1WF2-001	Needle bar	1	(GC20606-1L18)
22	1WF2-006	rocking pressing bar	1	
23	1WF5-010	Screw	1	SM11/64" \times 40/12
24	22T1-007	Washer	1	Washer GB848-85
25	1WF5-009	Needle bar holder guide	1	
26	1WF5-036	Pressing bar link	1	
27	1WF3-009	Screw	2	SM11/64" \times 40/15
28	1WF5-014	Guiding plate	1	
29	1WF5-016	Spring	1	
30	1WF5-015	Spring bar	1	
31	1WF5-043	Inner presser foot	1	(GC20606L18)
	35T5-502	Inner presser foot	1	(GC20606-1L18)
32	22T2-004	Screw	1	
33	1WF2-003	Needle holder	1	(GC20606L18)
	35T1-103	Needle bar thread guide	1	(GC20606-1L18)
34	1WF2-002	Needle holder screw	2	SM9/64" \times 40/4.3
	22T2-017	Needle set screw	1	(GC20606-1L18)
35	1F-009	Needle	2	DP \times 17 23#
36	1WF5-007	Needle bar rocking sliding block	1	
37	1WF5-008	Sliding block shaft	1	
38	1WF5-020	Needle bar rocking left crank	1	
39		Pin	1	A4 \times 24 GB117-86
40	1WF5-021	Washer	1	

4. Needle bar and lower feed components

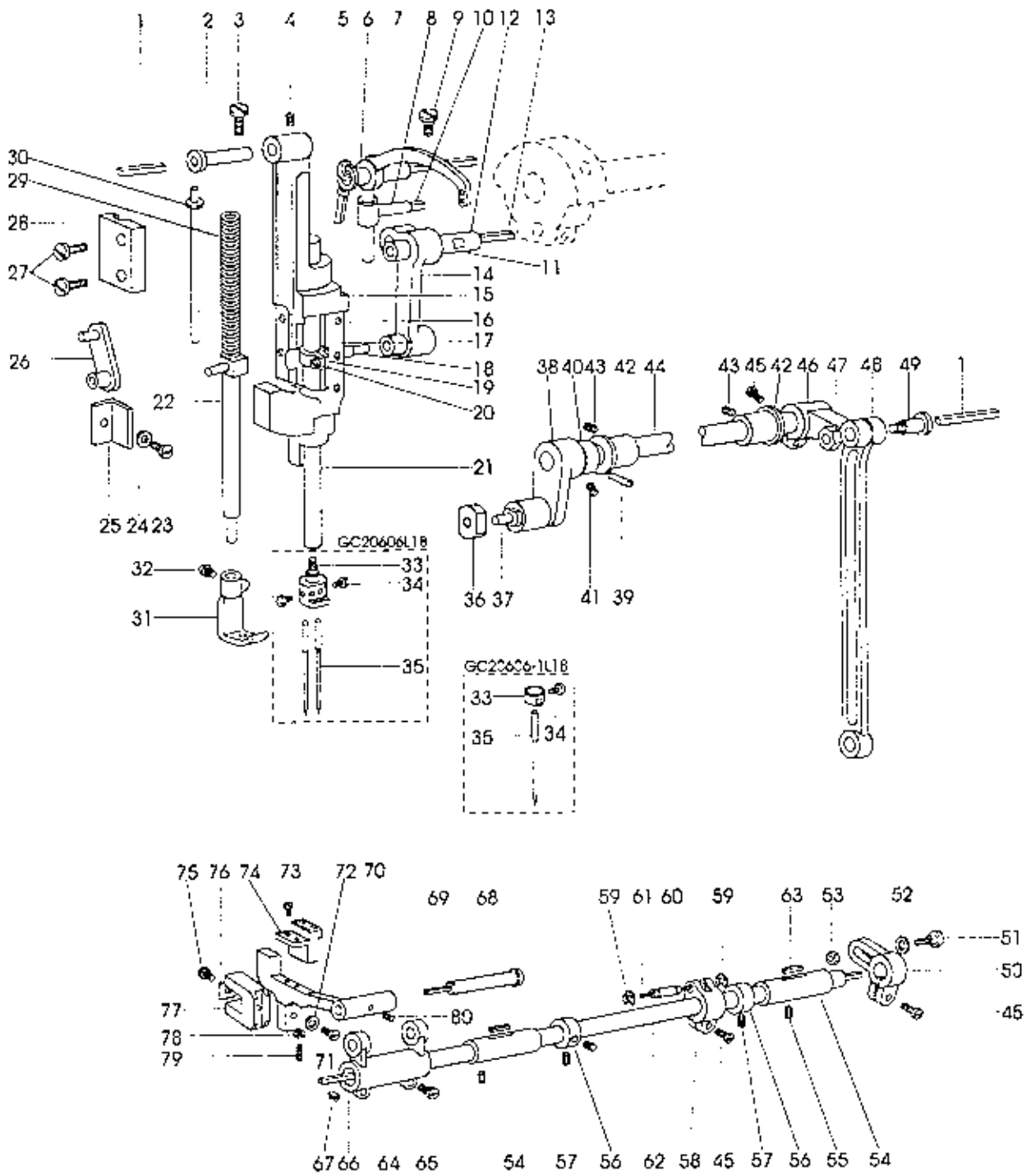

4. Needle bar and lower feed components

No.	Part number	Name	Qt.	Remark
41	1WF5-022	Screw	2	
42	1WF5-027	Bushing	2	
43	1WF5-028	Screw	2	SM1/4"×24/8
44	43WF5-001	Needle bar rocking shaft	1	
45	1WF4-018	Screw	3	
46	1WF5-005	Rear crank	1	
47	1WF5-004	Nut	1	
48	1WF5-003	Link lever	1	
49	1WF5-049	Screw	1	
50	1WF5-002	Feed shaft right crank	1	
51	1WF5-046	Pin	1	
52	1WF5-047	Washer	1	
53	1WF5-001	Nut	1	
54	1WF4-052	Feed shaft bushing	2	
55	1WF2-023	Screw	2	
56	1WF4-054	Collar	2	
57	1WF2-009	Screw	4	SM1/4"×40/4
58	1WF4-017	Feed crank	1	
59		Split stop ring	2	Stop ring 5 GB896-86
60	1WF4-019	Crank pin	1	
61	1WF4-020	Oil wick	1	φ3×55 cotton thread
62	43WF4-001	Feed shaft	1	
63	1WF4-038	Oil felt	2	Wool felt
64	1WF4-035	Connecting crank (left)	1	
65	1WF4-034	Screw	2	SM3/16"×28/12
66	1WF4-030	Oil wick	1	φ2.5×450 cotton thread
67	1WF4-029	Oil wick clamp	1	
68	1WF4-036	Crank shaft	1	
69	1WF4-031	Oil wick	1	
70	1WF4-001	Feed dog support	1	(GC20606L18)
	9WF4-001	Feed dog support	1	(GC20606-11.18)
71	1WF4-032	Screw	1	SM15/64"×28/16
72		Washer	1	Washer GB95-85
73	1WF4-005	Screw	2	SM1/8"×40/7
74	1WF4-004	Feed dog	1	(GC20606L18)
	9WF4-002A	Feed dog	1	(GC20606-11.18)
75	1WF4-007	Screw	1	SM1/8"×40/4
76	1WF4-008	Oil felt	1	Wool felt
77	1WF4-009	Feed dog lifting fork	1	
78	1WF4-002	Nut	1	
79	1WF4-003	Screw	1	SM1/8"×40/13.5
80	1WF4-033	Screw	1	SM11/32"×40/6

5. Lower shaft thread looping components

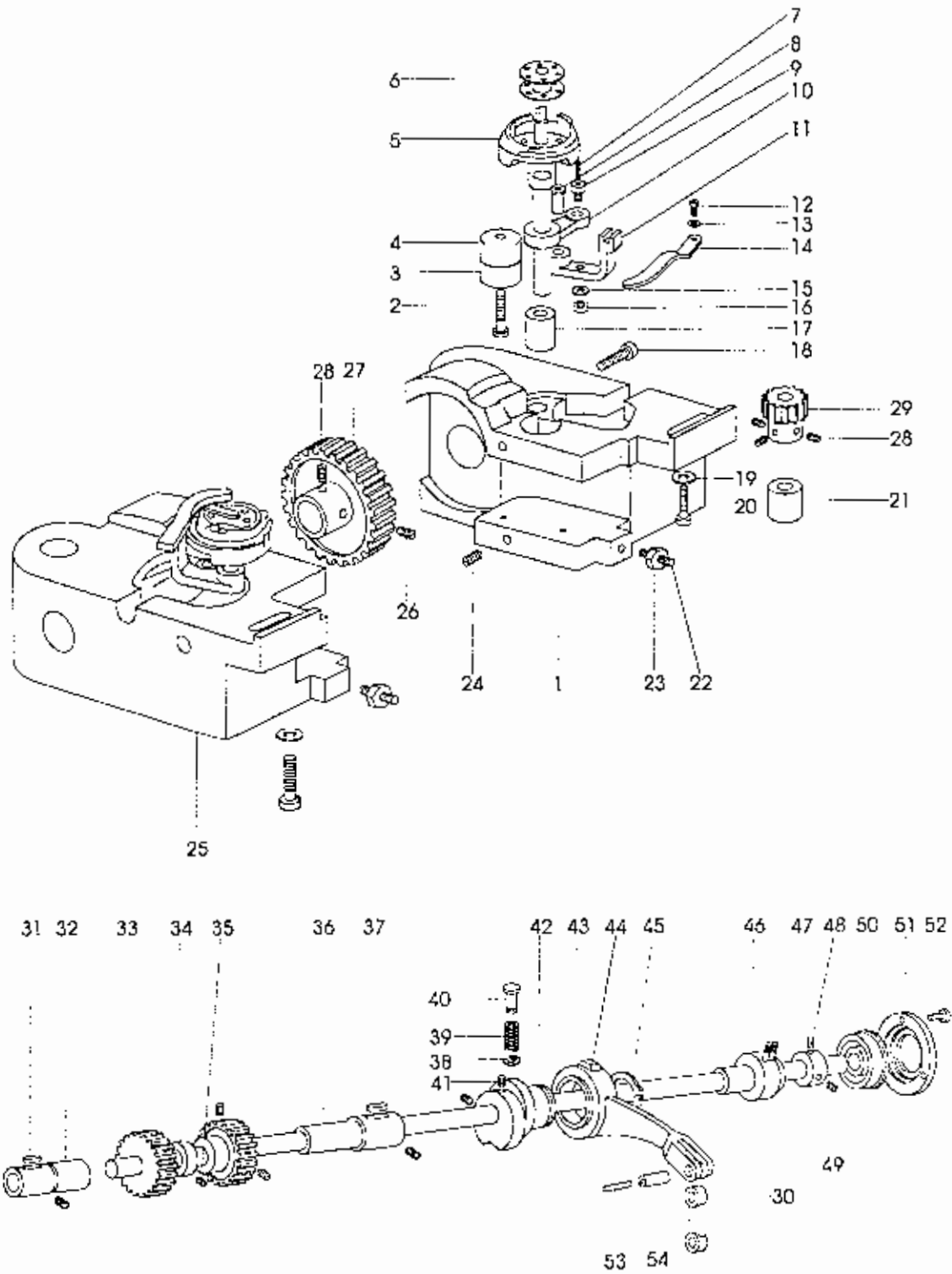

5. Lower shaft thread looping components

No.	Part number	Name	Qt.	Remark
1	1WF2-063	Right hook saddle	1	
2	1WF2-060	Screw	2 (1)	SM14/64"×28
3	1WF2-059	Upper bushing	2 (1)	
4	1WF2-061	Lower bushing	2 (1)	
5	1WF2-064	Rotary hook assembly	2 (1)	
6	1WF2-065	Bobbin	2 (1)	
7	1WF2-070	Oil wick	2 (1)	φ2.5×14 cotton thread
8	1WF2-069	Hinge shaft	2 (1)	
9	1WF2-072	Screw	2 (1)	SM3/16"×32
10	1WF2-071	Link lever	2 (1)	
11	1WF2-075	Inner hook finger bracket	2 (1)	
12	1WF2-026	Screw	2 (1)	SM9/64"×40/4.5
13		Washer	2 (1)	Washer 4 GB848-85
14	1WF2-076	Inner hook finger	2 (1)	
15		Washer	2 (1)	Washer 4 GB848-85
16	1WF2-074	Nut	2 (1)	SM3/16"×32
17	1WF2-062	Upper bushing	2 (1)	
18	1WF2-034	Screw	2 (1)	SM3/16"×28/14.5
19		Washer	2 (1)	Stop ring 6 GB95-85
20	1WF2-033	Screw	2 (1)	SM1/4"×24/20
21	1WF2-077	Lower bushing	2 (1)	
22	1WF2-067	Nut	2 (1)	SM3/16"×28
23	1WF2-066	Screw	2 (1)	SM3/16"×28/25.5
24	1WF2-044	Screw	2 (1)	SM1/4"×40/5
25	1WF2-068	Left hook saddle	1	
26	1WF2-052	Screw	2 (1)	SM1/4"×40/4
27	1WF2-078	Spiral gear	2 (1)	
28	1WF2-009	Screw	8 (4)	
29	1WF2-079	Spiral gear	2	
30	1WF2-055	Feed link	1	
31	1WF2-035	Lower shaft bushing (left)	1	
32	1WF2-036	Oil wick	1	φ2.5×45 cotton thread
33	43WF2-002	Lower shaft	1	
34	1WF2-006	Feed dog lifting cam	1	
35	1WF2-019	Screw	1	SM15/64"×28/12
36	43WF2-004	Lower shaft bushing (right)	1	
37	1WF2-058	Oil wick	1	φ2.5×85 cotton thread
38		Stop ring	1	Stop ring 5 GB896-86
39	1WF4-041	Spring	1	
40	1WF4-042	Button	1	
41	1WF4-010	Screw	2	SM15/64"×28/13.5
42	1WF4-011	Feed cam	1	
43	1WF4-012	Feed link	1	
44		Needle bearing	1	
45		Stop ring	1	Stop ring 26 GB894.1-86
46	1WF2-055	Lower shaft bushing assembly (middle)	1	
47	1WF2-051	Lower shaft bushing (rear)	1	
48	1WF2-009	Screw	1	SM1/4"×40/4
49	1WF2-052	Screw	1	SM1/4"×40/5
50		Bearing	1	
51	1WF2-050	Bearing pressing ring	1	
52	1WF2-049	Screw	3	SM9/64"×40/7
53	1WF4-044	Oil wick	1	
54	1WF4-043	Pin	1	

Note: the figure in the bracket is the parts quantity of GC20606-1L18

6. Stitch length adjustment components

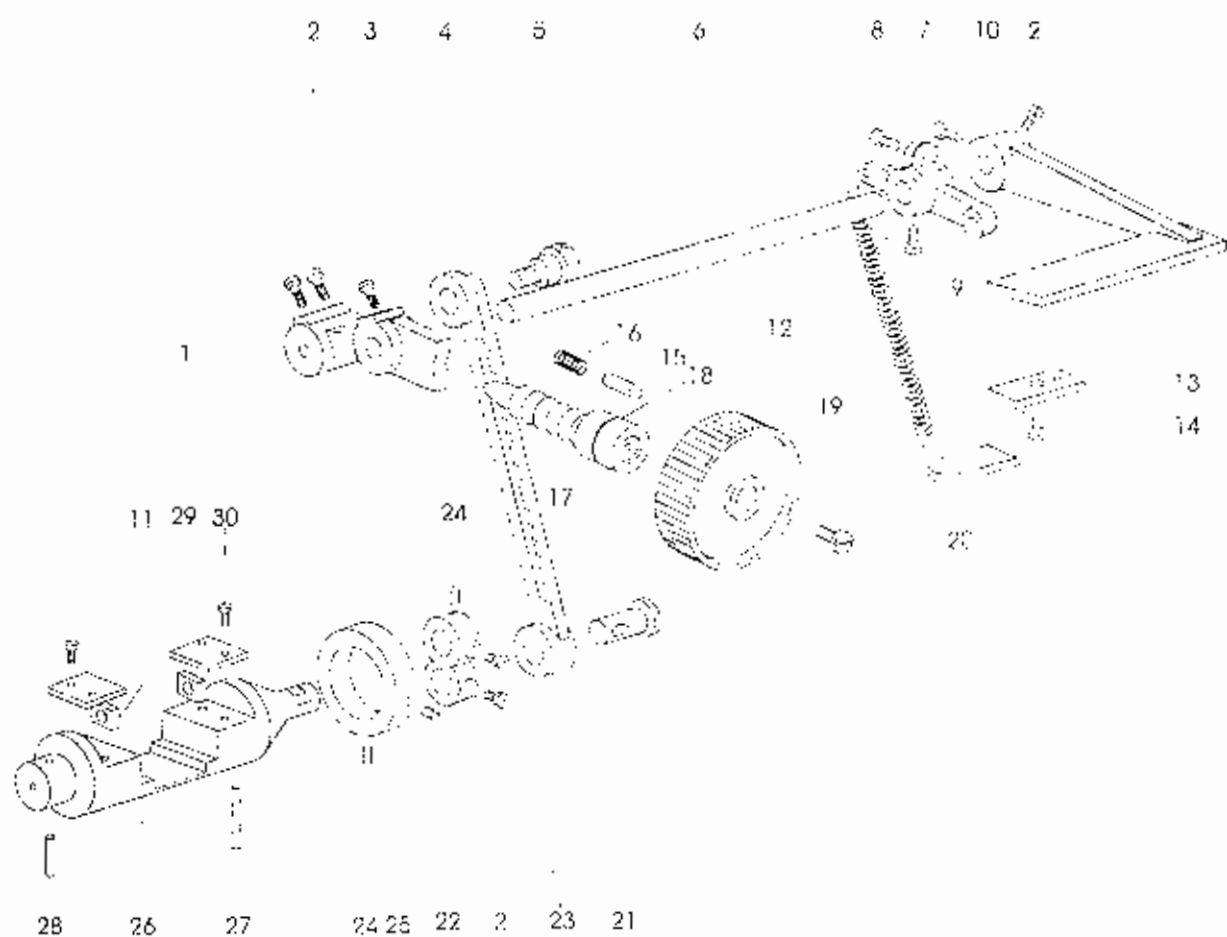

6. Stitch length adjustment components

No.	Part number	Name	Qt.	Remark
1	1WF4-025	Stitch length adjusting rocking lever	1	
2	1WF4-030	Screw	5	SM15/64"×28/8.5
3	1WF4-026	Set screw	1	SM15/64"×28/12
4	1WF4-014	Stitch length link	1	
5	1WF4-028	Eccentric shaft	1	
6	1WF4-046	Reverse feed shaft	1	
7	1WF4-047	Reverse feed crank	1	
8	1WF4-027	Screw	1	SM15/64"×28/13
9	1WF4-021	Screw	1	SM15/64"×40/10.5
10	1WF4-048	Reverse feed lever	1	
11	1WF4-040	Sliding block	2	
12	1WF4-049	Crank spring	1	
13	1WF4-050	Spring bracket	1	
14	1WF4-051	Screw	1	SM11/64"×40/8
15	1WF4-024	Stop pin	1	
16	1WF5-006C3	Spring	1	
17	43WF4-002	Screw bar	1	
18		'O' type seal	1	14×2.4 GBI235-86
19	1WF4-022	Stitch length dial	1	
20	1WF5-009	Screw	1	Interchangeable with GC6-1
21	1WF4-013	Stitch length adjusting crank shaft	1	
22	1WF4-015	Stitch length adjusting crank	1	
23	1WF2-038	Screw	1	SM15/64"×28/10
24	1WF4-016	Screw	3	SM15/64"×28/6
25	1WF4-053	Collar	1	
26	1WF4-057	Reverse feed adjusting bracket	1	
27	1WF4-045	Oil wick	1	φ3×26 cotton thread
28	1WF4-039	Oil wick	1	φ4×16 cotton thread
29	1WF4-056	Guiding plate	2	
30	1WF1-011	Screw	4	SM11/64"×40/9

7. Knee lifter and winding components

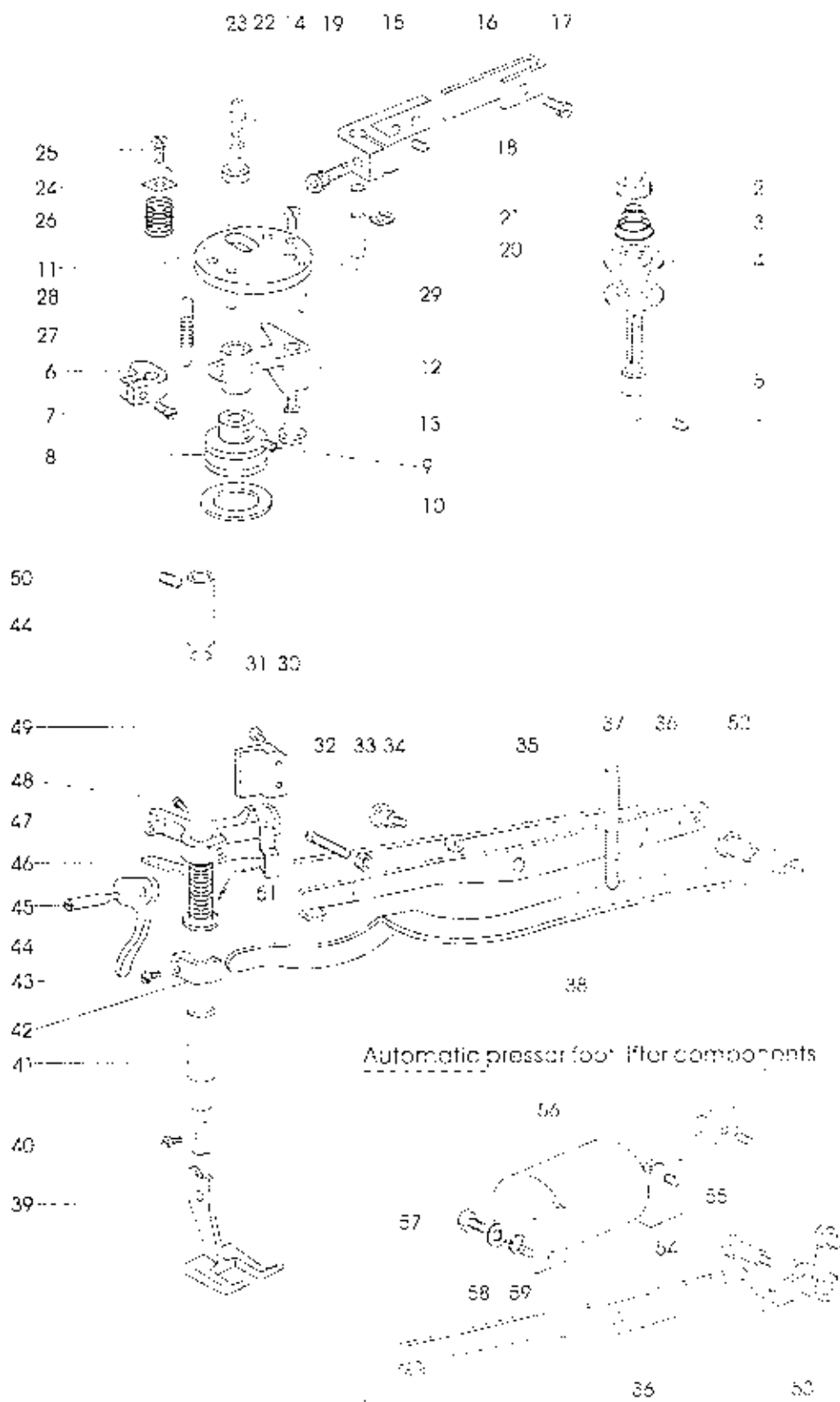

7. Knee lifter and winding components

No.	Part number	Name	Qty.	Remark
1	13WF4-027	Screw	1	
2	13WF6-029	Nut	1	
3	33T4-008C7	Thread tension spring	1	
4	22T1-012F5	Thread tension disc	2	
5	13WF6-028	Thread tension shaft	1	
6	13WF6-012	Crank	1	
7	13WF6-014	Screw	1	
8	13WF6-017	Bobbin winding pulley	1	
9	13WF6-018	Screw	2	
10	13WF6-019	Friction ring	1	
11	13WF6-001	Winder base	1	
12	13WF6-021	Winding crank	1	
13	13WF6-022	Pin	1	
14	13WF6-002	Screw (lower)	1	
15	13WF6-006	Winding spanner	1	
16	13WF6-007	Spring lever	1	
17	13WF6-008	Screw	1	
18	13WF6-009	Screw	1	
19	13WF6-010	Screw	1	
20	13WF6-011	Winding spanner shaft	1	
21		Stop ring	1	Stop ring 3.5 GB896-86
22	13WF6-015	Winder shaft	1	
23	13WF6-016	Locking ring	1	
24	13WF6-005	Bobbin thread trimmer	1	
25	13WF6-003	Screw (upper)	1	
26	13WF6-004	Spring	1	
27	13WF6-025	Spring	1	
28	13WF6-020	Positioning pin	1	
29	13WF6-013	Positioning pin	1	
30	1WF5-040	Slot for sliding block	1	
31	1WF5-039	Screw	2	SM1/64"×40/12
32	1WF3-011	Screw	1	SM1/4"×24/16.5
33	1WF3-010	Nut	1	
34	1WF3-013	Screw	1	
35	1WF3-014	Spring	1	
36	43WF3-001	Knee lifting lever	1	(For presser foot lifter by pedal)
	1WF3-012-D	Knee lifting lever	1	(For automatic presser foot lifter)
37	1WF3-015	Screw	1	
38	1WF3-016	Presser bar spring lever	1	
39	1WF3-001	Outer presser foot	1	(GC206060L18)
	9WF3-001	Outer presser foot	1	(GC20606-1L18)
40	1WF3-002	Screw	1	
41	1WF3-003	Presser bar bushing	2	
42	1WF3-005	Presser bar spring lever bracket	1	
43	1WF3-006	Screw	1	SM9/64"×40/8.5
44	1WF3-023	Presser foot lifting bar	1	
45	1WF3-022	Screw	1	
46	1WF3-007	Thread releasing plate	1	
47	1WF3-008	Presser bar guiding bracket	1	
48	1WF3-009	Screw	1	SM11/64"×40/15
49	1WF3-005	Presser bar	1	
50	1WF3-023	Screw	2	SM1/4"×24×23
51	1WF3-006	Thread releasing spring lever	1	
52	1WF3-018	Screw	1	
53	1WF3-019-D	Crank assembly	1	
54	1WF3-017-D	Screw	1	
55	43WF3-01-DB	Block	1	
56		Solenoid assembly	1	PF-9
57	43WF3-01-DA	Screw	2	
58		Washer	2	GB93-8
59		Washer	2	GB97.1-8

8. Lubrication components

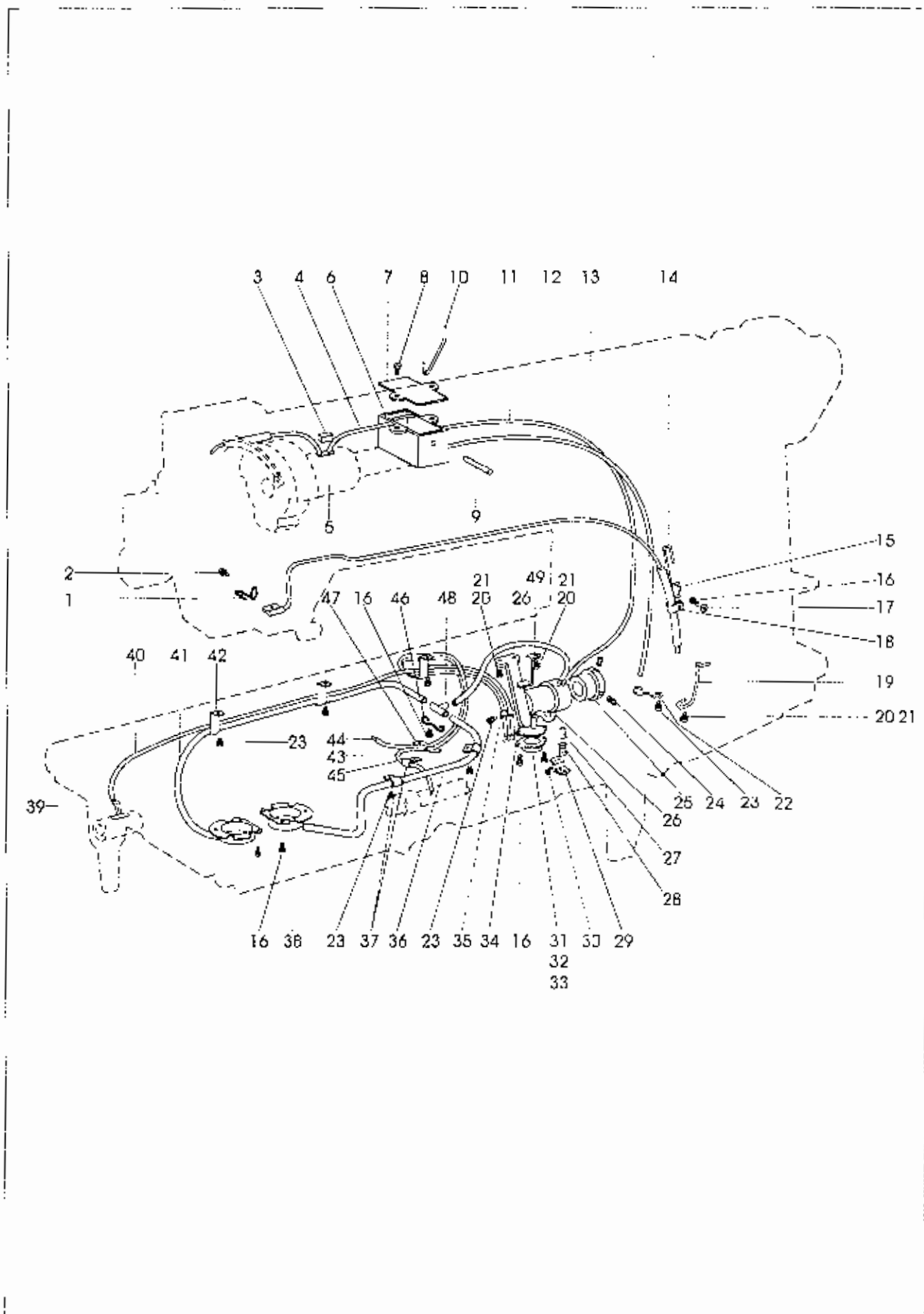

8. Lubrication components

No.	Part number	Name	Qty.	Remark
1	1WF6-001	Oil felt press spring	1	
2	1WF6-034	Screw	1	SM3/16"×28/12
3	1WF6-003	Oil felt	1	Wool felt
4	1WF6-005A	Oil pipe	1	3D×0.5×60
5	1WF6-004	Oil wick	1	Cotton thread
6	1WF6-007	Oil cup	1	
7	1WF6-008	Oil cup cover	1	
8		Screw	2	M4×16 GB69-85
9	1WF6-009	Pin	1	
10	1WF6-006	Oil wick press spring	1	
11	1WF6-010	Oil pipe	1	3D×1×400
12	1WF6-011	Oil draining pipe	1	5D×1×400
13	1WF6-002	Oil wick	1	φ2.5×550 cotton thread
14	1WF6-013	Oil pipe positioning clamp	1	
15	1WF6-012	Needle bar oil returning pipe	1	3D×0.5×150
16	1WF1-024	Screw	10	SM9/64"×40/9
17		Washer	1	Washer 4 GB7246-87
18	1WF6-042	Oil returning pipe clamp	1	
19	1WF6-014	Set spring	1	
20	1WF1-011	Screw	4	SM11/64"×40/9
21	22T1-007	Washer	4	
22	1WF6-021	Oil draining pipe end clamp	1	
23	1WF1-026	Screw	8	SM9/64"×40/4.5
24	1WF2-053	Screw	2	SM11/64"×40/10
25	1WF2-054	Bushing	1	
26	1WF6-027	Oil pipe	2	3D×1×90
27	1WF6-025	Plunger	1	
28	1WF6-024	Plunger spring	1	
29	1WF6-023	Plunger spring stopper	1	
30	1WF6-026	Screw	1	SM1/8"×44/4.5
31	1WF6-018	Oil filter	1	
32	1WF6-019	Washer	1	
33	1WF6-020	Filter net	1	H62 brassiness
34	1WF6-017	Oil filter fixing plate	1	
35	1WF6-028	Oil pipe clamp	1	
36	1WF6-035	Oil pipe for right hook saddle	1	
37	1WF6-036	Oil pipe clamp	3	
38	1WF6-038	Oil tray assembly	2	(GC20606L18)
		Oil tray assembly	1	(GC20606-1L18)
39	1WF6-031	Oil wick	1	φ2.5×430 cotton thread
40	1WF6-030	Oil pipe	1	3D×0.5×410
41	1WF6-039	Oil pipe	1	3D×1×445(GC20606L18)
42	1WF6-034	Oil pipe clamp	3	
43	1WF6-032	Oil pipe	2	3D×0.5×220
44	1WF6-037	Oil wick	1	φ2.5×300
45	1WF6-033	Oil wick	1	φ2.5×240
46	1WF6-030	Clamp	1	(GC20606L18)
47	1WF6-031	Oil pipe clamp	1	
48	1WF6-029	Oil nozzle assembly	1	(GC20606L18)
49	1WF6-015	Oil filter fixing bracket	1	

9. Accessories

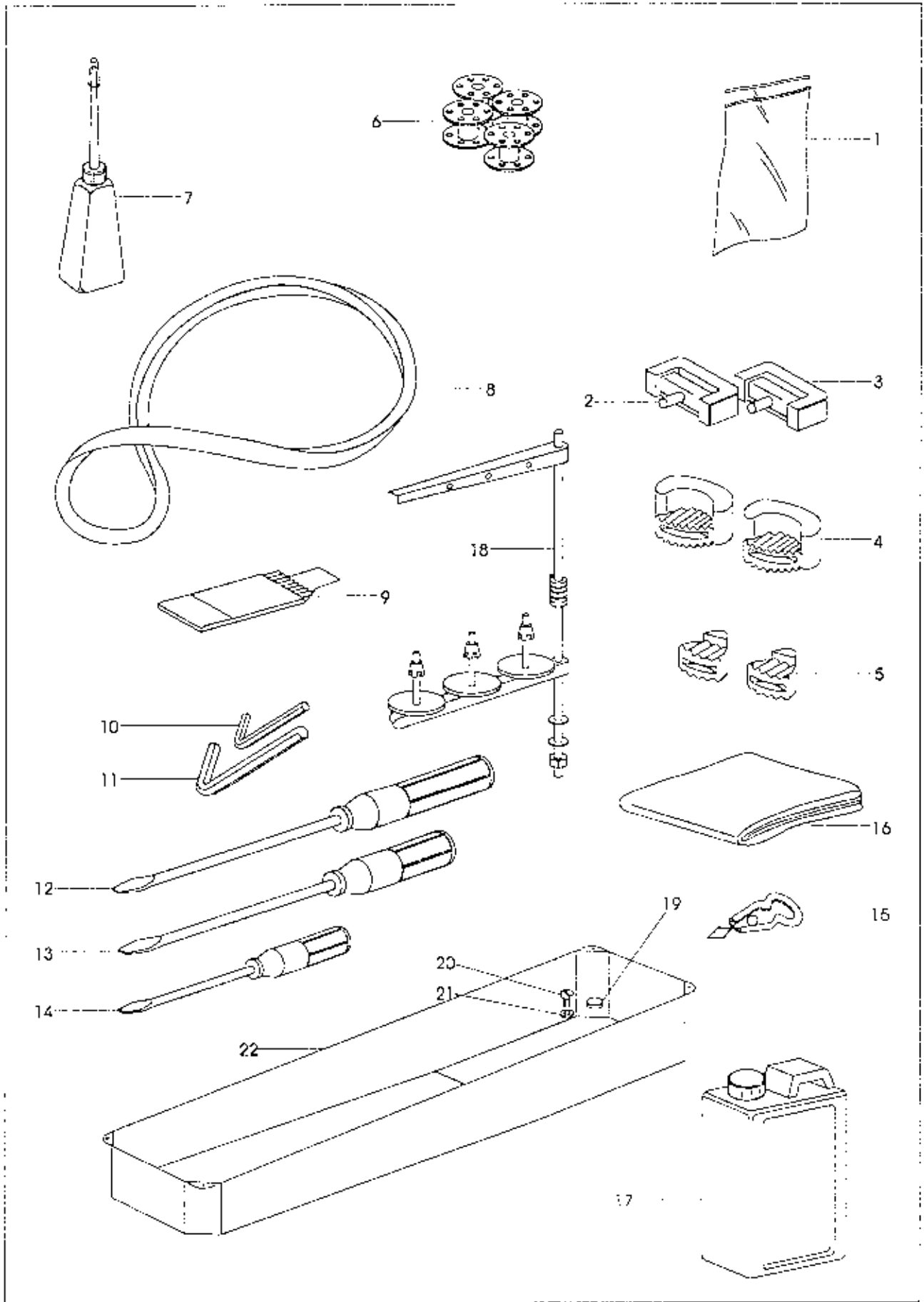

9. Accessories

No.	Part number	Name	Qt.	Remark
1	33TF-010	Parts bag	1	
2	22T9-007F1	Casting hinge	2	
3	22T9-007F2	Casting hinge cushion	2	
4	22T9-009	Casting cushion (big)	2	
5	22T9-010	Casting cushion	2	
6	1WF2-065	Bobbin	4	
7	33TF-011	Oil pot	1	
8	33TF-016	V-belt	1	'O' type 1050
9	1F-009	Needle	1 bag	DP × 17 23#
10	1F-011	Hexagon wrench	1	S=2.5MM
11	1F-010	Hexagon wrench	1	S=3MM
12	33TF-012	Screwdriver (big)	1	
13	33TF-013	Screwdriver (middle)	1	
14	33TF-014	Screwdriver (small)	1	
15	58T0-007C	Needle thread guide assembly	1	
16	22T9-018	Machine head cover	1	
17	1F-012	Oil tank	1	
18	1F-014	Thread stand	1	(GC206060L18)
	33TF-019	Thread stand	1	(GC20606-1L18)
19	22F9-012	Magnet	1	
20	22T9-001A2	Oil draining screw	1	SM5/16" × 25/10
21	22T9-001A3	Wash	1	
22	43WF3-002	Oil pan	1	

- Please don't adjust and repair the machine by non-professionals,except adjusting stitch.
- Specifications subject to change without notice

TYPICAL SEWING MACHINE WANPING MACHINERY CO.,LTD.

ADD: WANPING TOWN, WUJIANG CITY, JIANGSU
PROVINCE, CHINA

TEL: +86-512-63391278

FAX: +86-512-63391371

POST. CODE: 215223

Http://www.typicalwpchina.com

E-mail:export@typicalwpchina.com

2013.11