



YSC-8361

AC Servo System

Instruction manual

IMPORTANT
READ CAREFULLY BEFORE USE
KEEP FOR FUTURE REFERENCE

YSC-8361 controller is used for an industrial sewing machine. With industrial sewing machine, it is normal to carry out work while positioned directly in front of moving parts such as the needle and thread take-up, and consequently there is always a danger of injury that can be caused by these parts. So when you ready to operate the machine, please follow the instructions from trained personnel and instructors regarding safe and correct operation.

1. NOTICE

1.1 Work environment

- ▲ Please use 220V AC in $\pm 10\%$ ranges.
- ▲ To avoid the false operate, please keep the product away from the high electromagnetic interference.
- ▲ Please operate in the area which temperature is $5^{\circ}\text{C} \sim 45^{\circ}\text{C}$ and humidity is 80% or less.

1.2 Notice of installation

- ▲ Turn off the power and unplug the cord before installation.
- ▲ The wire must not set to be near the wheel and other movable parts.
- ▲ To avoid the static interference and current leakage, all grounding must be done.

1.3 Notice of safety

- ▲ Turn off the power before maintenance and repairs or raising the machine arms, or changing needle, or threading needle.
- ▲ Please don't open the box except the professional.
- ▲ When turn on the machine in the first time, use low speed to operate and check the correct rotation direction.
- ▲ During machine operation, don't touch any moving parts.
- ▲ All moving parts must use the protective device to avoid the body contact and objects insertion.
- ▲ When there is water or other liquid, or caustic material on box or motor, you must stop operation and turn off the power.
- ▲ All connector shouldn't be plug and unplug when power on.
- ▲ The connector should be plug and unplug in the correct method.

2. INSTALLATION AND ADJUSTMENT

2.1 Dimension of control box and speed controller bracket(direct driven)

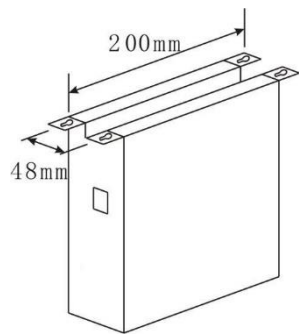

Control box

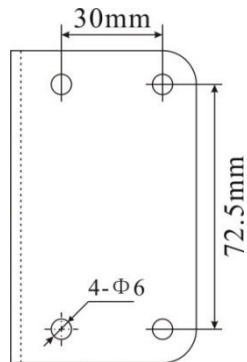

Speed controller bracket

2.2 Speed controller

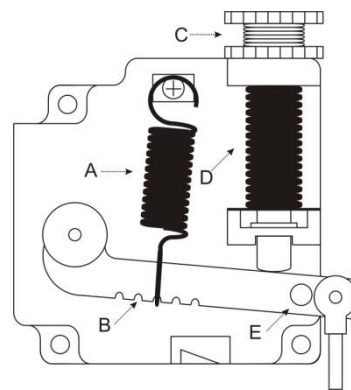
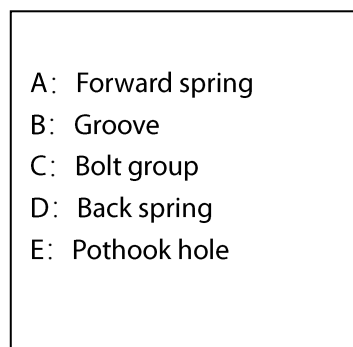

2.3 Installation diagram of system

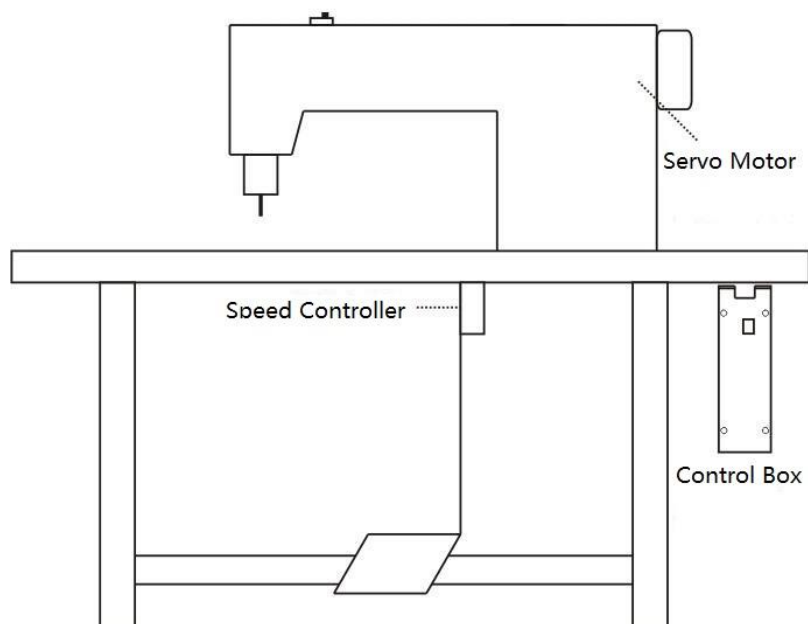

3. ELECTRICAL CONNECTION

3.1 Connecting the power supply

Work on the electrical equipment may only be performed by qualified technicians or personal who have undergone the necessary training.

Always pull the power plug before working on the electrical equipment.

Connect the control to a grounded AC voltage, the rated voltage is in the range of $220V + 10\%$

3.2 Single phase 220V power connection

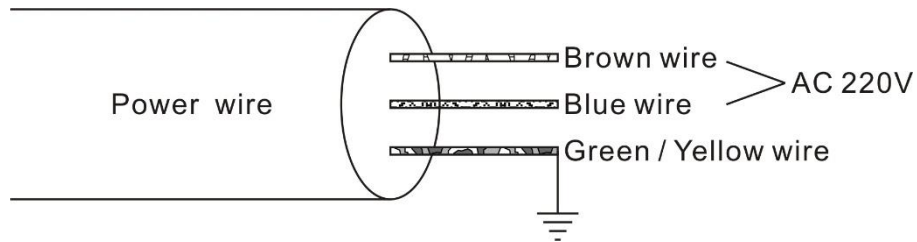

3.3 Three phase 380V power connection

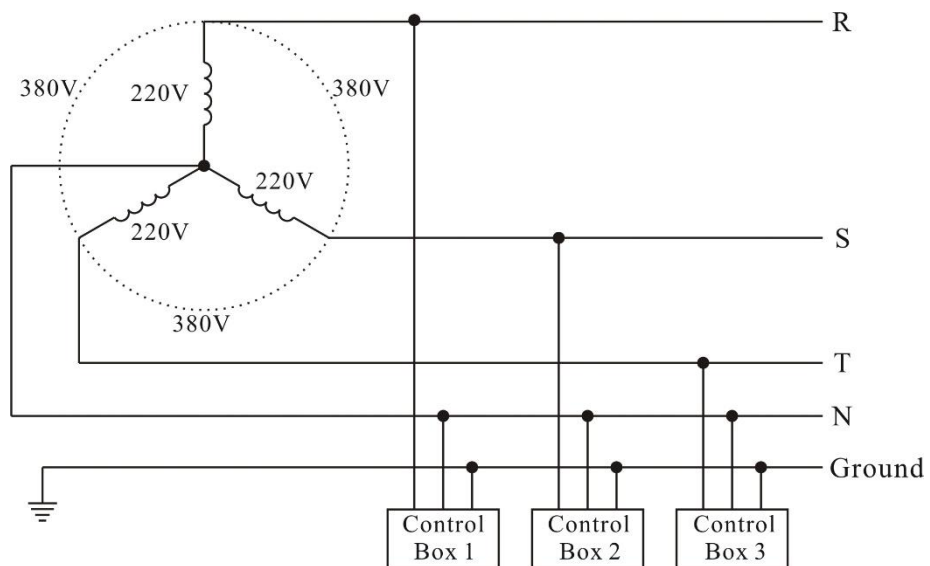

4. CONNECTOR DIAGRAM

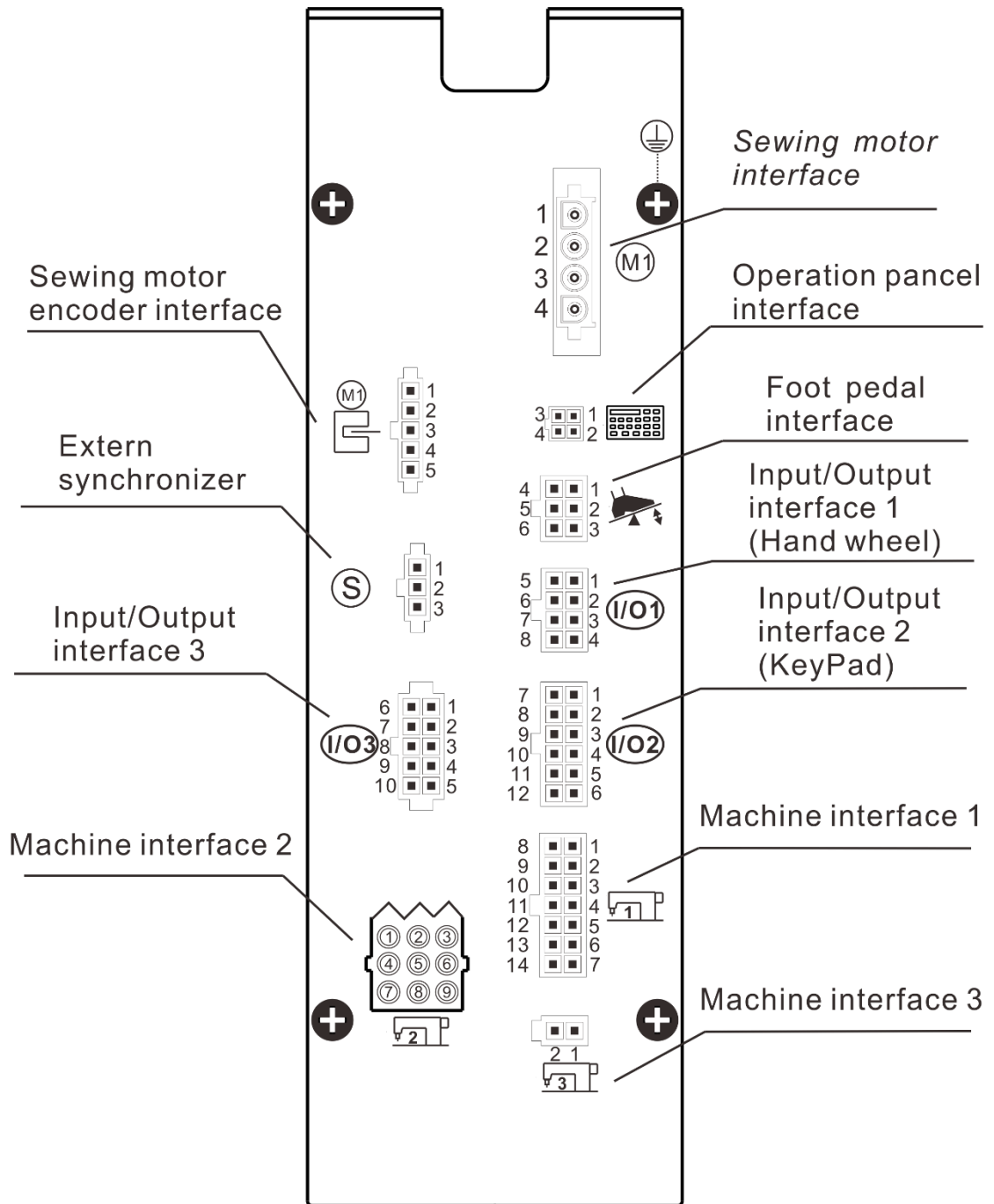

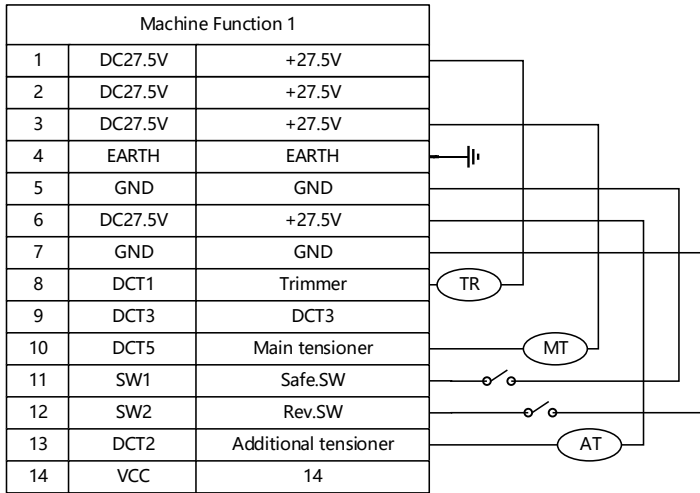

Encoder	
1	DC-5V
2	GNDS
3	JT-UP
4	MC-CHA
5	MC-CHB

Sewing motor	
1	EARTH
2	A Phase
3	B Phase
4	C Phase

Pancel	
1	VCC
2	GND
3	RXD21
4	TXD21

Foot Pedal	
1	IO3-IN
2	IO6-IN
3	IO2-IN
4	Pedal
5	GND
6	VCC

Keypad	
1	GND
2	GND
3	IO12-OUT
4	IO11-OUT
5	IO8-IN
6	VCC
7	IO1-IN
8	IO5-IN
9	IO4-IN
10	IO9-IN
11	IO10-OUT
12	VCC

Synchronizer	
1	VCC
2	JT-UP-A
3	GND

Hand wheel	
1	GND
2	GND
3	IO13-IN
4	IO7-IN
5	CHB-IN
6	CHA-IN
7	Z-IN
8	VCC

Machine Function 3	
1	DC27.5V
2	DCT4

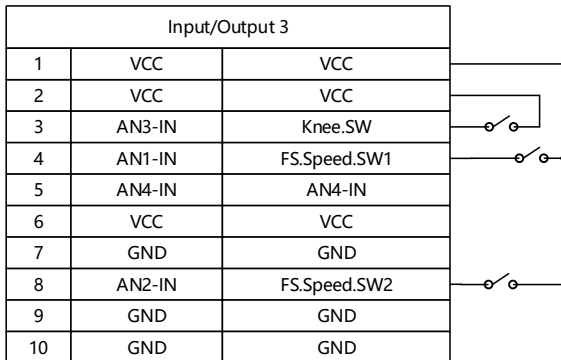
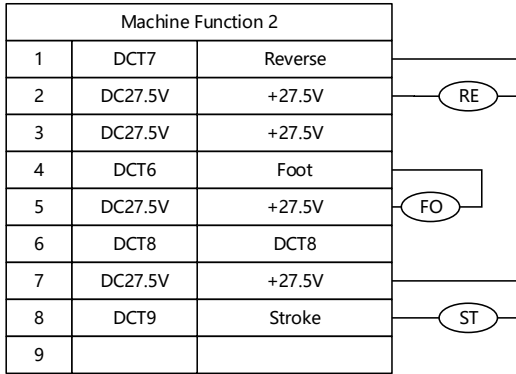

Solenoid Abbreviatons	
TR	Trimmer
MT	Main tensioner
AT	Additional tensioner
RE	Reverse
FO	Foot
SL	Stitch length
ST	Stroke
CL	Clamp
MD	Seam middle guide

20665 series

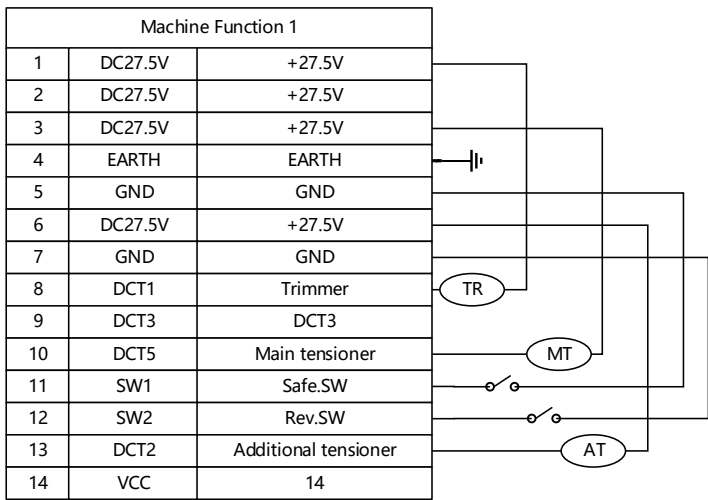

Encoder		Sewing motor	
1	DC-5V	1	EARTH
2	GNDS	2	A Phase
3	JT-UP	3	B Phase
4	MC-CHA	4	C Phase
5	MC-CHB		

Panel	
1	VCC
2	GND
3	RXD21
4	TXD21

Foot Pedal	
1	IO3-IN
2	IO6-IN
3	IO2-IN
4	Pedal
5	GND
6	VCC

Keypad	
1	GND
2	GND
3	IO12-OUT
4	IO11-OUT
5	IO8-IN
6	VCC
7	IO1-IN
8	IO5-IN
9	IO4-IN
10	IO9-IN
11	IO10-OUT
12	VCC

Synchronizer	
1	VCC
2	JT-UP-A
3	GND

Hand wheel	
1	GND
2	GND
3	IO13-IN
4	IO7-IN
5	CHB-IN
6	CHA-IN
7	Z-IN
8	VCC

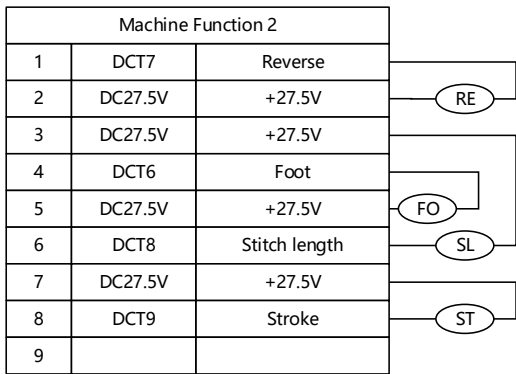

Machine Function 3	
1	DC27.5V
2	DCT4

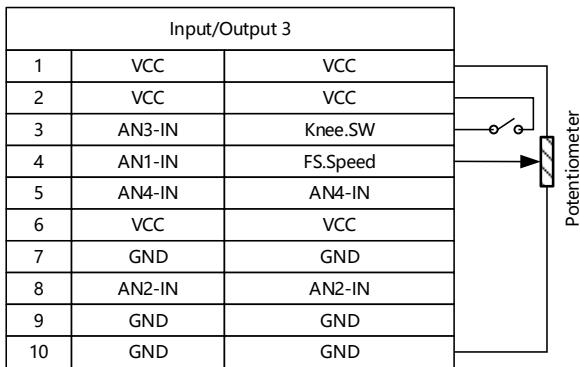







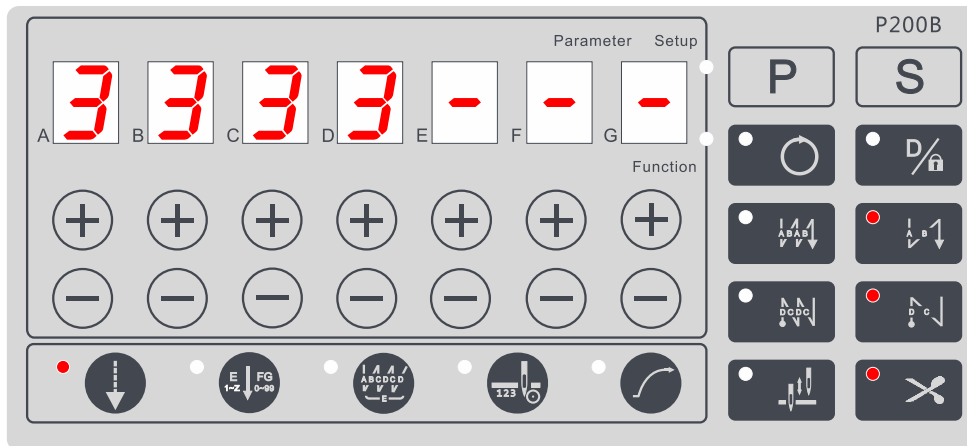

Solenoid Abbreviations	
TR	Trimmer
MT	Main tensioner
AT	Additional tensioner
RE	Reverse
FO	Foot
SL	Stitch length
ST	Stroke
CL	Clamp
MD	Seam middle guide

898 series

5. OPERATING FIELD P200B

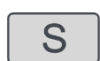

Start backtack		Single start tacking, A is the stitches of forth sewing; B is the stitches of back sewing. They are both in range 1~15
		Double start tacking, A is the stitches of forth sewing; B is the stitches of back sewing. They are both in range 1~15.
End backtack		Single end tacking, C is the stitches of back sewing; D is the stitches of forth sewing. They are both in range 1~15
		Double end tacking, C is the stitches of back sewing; D is the stitches of forth sewing. They are both in range 1~15
Free Sewing		<p>▲ As the pedal is stepped forward, the starttacking(if selected) will be done automatically, then machine will start normal sewing. Once the pedal returned to balance, machine will stop immediately.</p> <p>▲ As the pedal stepped backward, the end tacking, trimming and wiping(if selected) will be done automatically</p>
Constant-Stitch Sewing		<p>▲ Once the pedal is stepped forward, F, G stitches will be completed with E times.</p> <p>▲ Constant-Stitch Sewing will perform the number of segments and times as setting, when the stitches are zero, machine will stop immediately.</p>
Bar-Tacking Sewing		<p>▲ Once the pedal is stepped forward, all the seams of bar tacking, A, B, C, D sections will be completed with E times, and the trimming will be done automatically.</p> <p>▲ The pedal must be returned to balance for next sewing.</p>
Lower thread Counter		Enter lower thread counter interface

Soft start		Enable or disable the soft start
Needle Up / Needle Down		Select the stop position of needle bar
Trimming Enable		Enable or disable the trimming
Interface Selection		Switch current interface to another
One-Key Default /Lock keys		▲ Sewing interface: lock the keypad ▲ Parameter interface: restore a parameter to default
Parameter Function		Enter or exit parameter function interface
Save		Confirm and save current value of parameter
Add		Value increase
Sub		Value decrease

6. GET STARTED WITH YOUR MACHINE

Before operating the controller, the following items must be inspected and set up to ensure safe and reliable operation:

6.1 Machine ID

6.1.1 How to change the machine ID

Press hold 『A+』 key and turn on the power to access to adjust the machine ID, seven-segment displays F,G will display the ID, change it



and press  to save.

6.1.2 Table of machine ID

ID	Model	Unit(sti/min)
1	GC20665KL14D3T3	2500
2	GC20665L14D3T4	2500
3	GC20666L14D2T4	2200
4	TW1-898L14D2T5	3500
5	TW1-999L14D2T5	2800
6	TW1-999L14D3T5-001	2800
7	TW1-899SL14D2T5	2800
8	TW2-898L14D2T5	2800
9	TW2-999L14D2T5	2500
10	GC24676BD2T5	2500
11	GC20676L14D2T3	2200
12	GC2263-1D3T3	2500
13	TW1-899L14D2T4	2800

14	TW2-899L14D2T4	2500
----	----------------	------

6.2 Adjust the ZERO OF THE MACHINE

- Press  and switch on the power, the panel displays “ZERO”
- Turn hand wheel slowly, the panel displays the current degree.
- When the needlebar is at the highest position, press  to confirm and save
- Restart the control box

7. OPERATING ELEMENTS

7.1 Single start back-tacking setting

- A Stitches = 0
Seven-segment display A display 『-』 .
Sewing process: B stitches back – normal sewing.
- A Stitches ≠ 0
Sewing process: A stitches forth – B stitches back – normal sewing

7.2 Double start back-tacking setting

- A Stitches = 0
Sewing process: B stitches back – B stitches forth – B stitches back – normal sewing.
- A Stitches ≠ 0
Sewing process: A stitches forth – B stitches back – A stitches forth – B stitches back – normal sewing

7.3 Single end back-tacking setting



- D Stitches = 0
Seven-segment display D display 『-』 .
Sewing process: C stitches back – end.
- D Stitches ≠ 0
Sewing process: C stitches back – D stitches forth – end.



7.4 Double end back-tacking setting

- D Stitches = 0
Sewing process: C stitches back – C stitches forth – C stitches back – end.
- D Stitches ≠ 0
Sewing process: C stitches back – D stitches forth – C stitches back – D stitches forth – end.

7.5 Lower thread counter



Set A11 to “1” to active the counter.

- **Enter interface:** Press  Or Special function interface SN F6(refer to 6.6).
- **Initialize the counter:** Press , the initial value of the lower thread counter which was set previously will be shown. Adjust it to a suitable value.
- **How the counter works:**

- Display initial value
- The counter reduces by 1 for every 10 stitches sewn.
- If the counter less than 1, the display area twinkled and buzzer sounds for 3 times. The machine will not start up again. Press  the warning will disappear and sewing will be possible, the counter reduces continue.
- Press  again, the display will return to the initial value

7.6 Product quantity counter

Set A11 to "1" to activate the counter.

- **Enter interface:** Special function interface SN F2, refer to 6.2
- **Data acquisition:** In SN F2 interface, press  will be into collect process interface, seven-segment display D displays [L], seven-segment displays E,F,G will display the number of stitches for this process. It records the number of stitches and the number of trimmer. Press  to save the data and return SN F2 interface.
- **How the Counter works:** If sewn the number stitches more than the number of stitches collected 90%, and the number of trimming times more than collected, the counter add 1.
- **Clear Counter:** press 

7.7 Adjust the backtack

- Adjusting of RVE.SOL action time

For start/end backtack or bar tacking, if unbalanced situation is appeared during natural direction to reverse direction, please correct it as below:

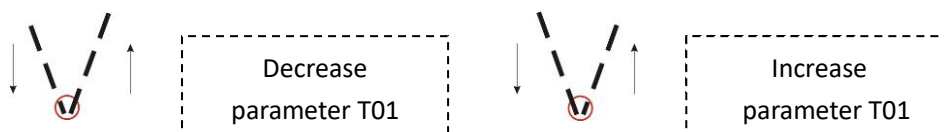

- Adjusting of RVE.SOL release time



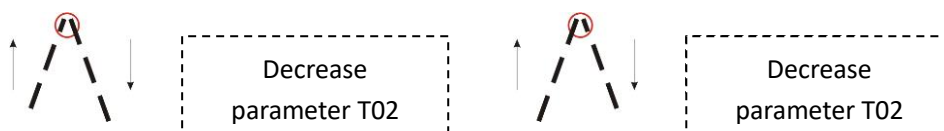



For start/end tacking or bar tacking, if unbalanced situation is appeared during reverse direction to natural direction, please correct it as below:



7.8 Quick functions on the keypad



Figure 1: Keypad on the machine arm

Foot stroke		Toggle foot stroke level
Start and end strips		This key cancels the general setting for sewing start and end strips. If strips are activated, pressing the key disables the next strip. If no strips are activated pressing the key sews the next strip.
Position of the needle		If the key is selected the needle moves to a specific position. This position is determined individually via the parameter settings, more information read D15, D16
Stitch Length		If this key is selected, the machine sews using the smaller stitch length selected at lower adjusting wheel for the stitch length
Additional thread tension		This key switches on the additional thread tension
Pause		If the pause switch is triggered, all functions are locked except parameters, the adjacent led light up, panel display "PAUSE"

7.9 Lock the hot keys and keypad

if  key is triggered, all functions on the keypad and hot keys are invalid.

7.10 Electronic hand wheel

Turning the hand wheel:

The value of "A23" is 1, electronic hand wheel is activated. By turning the hand wheel, you can move the needle bar forwards or backwards.

7.11 Hot keys

Pressing the Reverse switch:

Default: Reverse.

Refer to Parameter list, A04.

Pressing the hand wheel:

Default: None

Refer to Parameter list, A05.

7.12 Quick stroke adjustment via knee switch

On machines with quick stroke adjustment activated via a knee switch, the elevated sewing foot stroke is switched via the knee switch.

8. OPERATION OF THE SPECIAL FUNCTION INTERFACE

Press  could be access special function interface from normal function interface, showed as below:

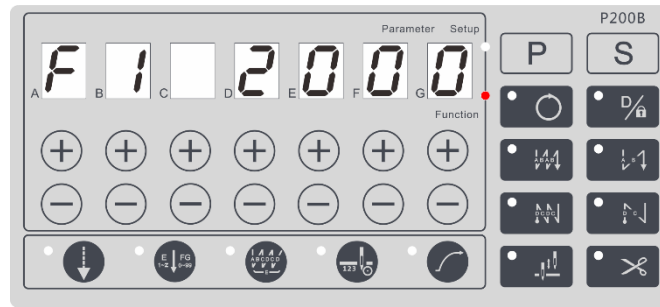

Figure 2: Function Interface

Bar A and B according to SN of function, bar D~G display contents, press **B+** and **B-** to select function:

8.1 Dynamic speed limitation

SN F1: display current speed up limitation, could be change during running.

8.2 Product quantity counter

SN F2: display the product quantity

8.3 Machine degree

SN F3: display the machine degree.

8.4 Torque enhancement function at low speed

SN F4: display D: press **D+** and **D-** to open/close the function.

Display F,G: 0~10, the gear.

8.5 Actual speed display

SN F5: display the actual speed.

8.6 Lower thread counter

SN F6: display how much the lower thread is remaining

9. PARAMETER INSTRUCTION

9.1 Setting parameter

Press to enter Parameter Interface.

Seven-Segment display E display the parameter type, press "**E+**" and "**E-**" key to change it.

Seven-Segment display F, G display the parameter index, press "**F+**", "**F-**", "**G+**", "**G-**" key to change it.

Seven-Segment displays A, B, C, D display the parameter value, press the keys under them to change it.

For example, Graph4: parameter index is 1, type is P, value of "S01" is 2000, the nixie tube will blink when change the value. Press to confirm, press to cancel and return to sewing interface.

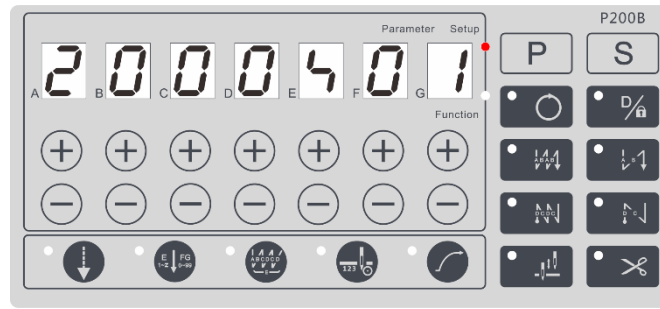

Figure 3: Parameter Interface

9.2 Get the permission of setting O type parameter

Only S, T and A type parameter can be select normally, if you want to change the O type parameter, you must power on while press **P** key, when you see 『DO EN』, you get the permission successfully.

9.3 Parameter solidifying

If users want to change some parameter's default value, then select the parameter, press **○** maintain a moment, after 『SD OK』 displaying, the default value has been changed.

9.4 Restore parameter through one-key default

Select any parameter in parameter interface, **D/A** can be used to recall the default value. The bar will be twinkling if modified, use **S** to confirm or **P** repeal change

9.5 Controller recovery

■ Resume the default value of all parameters

Set parameter **O17** to "ON", turn on the power again, after twinkling of "INIT" finished, all parameters have been default value themselves

■ Restore Factory Defaults

Set parameter **O51** to "ON", turn on the power again.

9.6 Abate safety switch

If you want to abate the function of Safe SW., you can change the value of "**O31**" from "1" to "0" normally, in a particular case, for example, the Safe SW. broke down, you can power on while press "**C+**" key to abate the function of Safe SW.

warning : it means potential security problems for you if you abate the function of Safe SW., so attention please.

9.7 General parameter table

SN	RANGE	DESCRIPTION
S type Parameter		
S01	500~3500spm	Maximum sewing speed
S02	150~500spm	Minimum sewing speed
S03	500~2000spm	Speed adjustment for start back-tacking

S04	500~2000spm	Speed adjustment for end back-tacking
S05	500~2000spm	Speed adjustment for bar-Tacking
S06	500~2000spm	Speed adjustment for constant-stitch sewing
S07	150~300spm	Speed adjustment for trimmer
S08	200~500spm	Soft start speed
S09	500~3500spm	Speed adjustment for foot stroke gear 1
S10	500~3500spm	Speed adjustment for foot stroke gear 2
S11	500~3500spm	Speed adjustment for foot stroke gear 3
S12	500~3500spm	Speed adjustment for foot stroke gear 4
S13	500~3500spm	Speed adjustment for foot stroke gear 5
S14	500~3500spm	Speed adjustment for foot stroke gear 6
S15	500~3500spm	Speed adjustment for min-foot stroke
S16	50~500spm	Speed adjustment for pull back after trim
T type Parameter		
T01	1~200(millisecond)	Action time of the REV SOL.
T02	1~200(millisecond)	Release time of the REV SOL.
T05	1~500(millisecond)	Foot lifer-Delay time adjustment for pedal's feet lift position
T06	1~500(millisecond)	Running delay time adjustment for Automatic Foot Lifer
T09	1~1000(millisecond)	Safety switch-Delay time adjustment for machine vibration
T10	1~200(millisecond)	Pedal-Delay time adjustment for pedal vibration
T11	1~1000(millisecond)	Delay time adjustment when A20/A22 set as 1
A type Parameter		
A01	0~1	Needle positions 1 = Up Position 0 = Down Position
A02	0~1	Automatic Constant-Stitch sewing 1 = On 0 = Off
A03	0~1	Correction stop mode 1 = stop position accord to D15, D16 0 = random
A04	0~13	Function selection of reverse switch 0 = none 1 = reverse 2 = forward correction 3 = backward correction 4 = forward correction at machine stop, reverse at machine run 5 = backward correction at machine stop, reverse at machine run

		6 = none 7 = none 8 = trim at normal sewing, foot lifer after trimming 9 = foot stroke 10 = single backtack supression 11 = 2 nd STITCH LENGTH 12 = additional thread tension 13 = thread mode
A05	0~13	Function selection of hand wheel switch, refer to A04
A06	0~1	Trim selection 1 = trimmer valid 0 = trimmer invalid
A07	0~1	Lock machine buttons selection (machine buttons includes Hot Keys, Hand Wheel Switch, Reverse Switch) 0: machine buttons work 1: machine buttons not work
A09	0~1	Foot lift selection 1: Foot lifer function valid 0: Foot lifer function invalid
A10	0~1	Clamp selection 1: Clamp valid 0: Clamp invalid
A11	0~1	Product Quantity Counter 1 = On 0 = Off
A12	0~1	Lower thread Counter 1 = On 0 = Off
A13	0~1	Pull Back after Trim (angle refer to O35) 1 = On 0 = Off
A14	0~1	Automatic Foot Lifer when stopped 1 = ON 0 – Off
A15	0~1	Automatic Foot Lifer after trimming 1 = On 0 = Off
A16	0~1	Automatic constant-stitch sewing after start backtacking (only when A02=0) 1 = On 0 = Off
A17	0~1	Automatic end backtacking for constant-stitch sewing (only when A02=0)

		1 = On 0 = Off
A18	0~1	Upper position when switch on the control 1 = On 0 = Off
A19	0~2	Function when Half-Heeling the pedal 2: thread cutting 1: foot lift 0: Balance
A20	0~1	Mode of start back-tacking (only for free sewing) 1: stitch for stitch 0: normal
A21	0~1	Soft start
A22	0~1	Mode of end back-tacking (only for free sewing) 1: stitch for stitch 0: normal
A23	0~1	Electronic handwheel 1 = On 0 = Off
A27	0~3	Mode of thread tension and thread tension reduction when sewing foot lift is active 0 = no thread tension lift 1 = thread tension lift in the seam 2 = thread tension lift after trimming 3 = thread tension lift in the seam and after trimming
A28	0~1	Automatic open additional thread tension when foot stroke adjust 0 = not related to Knee SW. ; not related to Keypad ; 1 = related to Knee SW. ; not related to Keypad ; 2 = not related to Knee SW. ; related to Keypad ; 3 = related to Knee SW. ; related to Keypad ;
A30	0~1	Correction mode 0: single correction 1: continuously correction
A36	0~11	Quick function on the keyboard key1 0: none 1: foot stroke 2: start and end strips 3: forward correction 4: stitch length 5: additional thread tension 6: pause 7: add power when low speed 8: reverse

		9: parting foot 10: threading mode 11: backward correction
A37	0~11	Quick function on the keyboard key2 Refer to A36
A38	0~11	Quick function on the keyboard key3 Refer to A36
A39	0~11	Quick function on the keyboard key4 Refer to A36
A40	0~11	Quick function on the keyboard key5 Refer to A36
A41	0~11	Quick function on the keyboard key6 Refer to A36
A43	0~1	Electronic handwheel rotation and motor steering correspondence 0: same 1: opposite
A50	0~1	Start with 2 nd stitch length
A51	0~3	Mode for automatic raising of the seam middle guide 0: Do not raise 1: With sewing foot lift 2: During bark-tacking and reverse 3: During back-tacking and reverse and sewing foot lift
D type Parameter		
D01	0~359(°)	Angle of needle bar up lever
D02	0~359(°)	Angle of needle bar down lever
D03	0~359(°)	Switch-on angle of Trimmer
D04	0~359(°)	Switch-off angle of Trimmer
D05	0~359(°)	Switch-on angle of Reverse SOL.
D06	0~359(°)	Switch-off angle of Reverse SOL.
D07	0~359(°)	Switch-on angle of thread clamp
D08	0~359(°)	Switch-off angle of thread clamp
D13	0~359(°)	Switch-on angle of thread tension
D14	0~359(°)	Switch-off angle of thread tension
D15	0~359(°)	Correction angle 1
D16	0~359(°)	Correction angle 2
D17	0~359(°)	Switch-on angle of short thread trimmer (only for TW1-999L14D3T5-001)
D18	0~359(°)	Switch-off angle of short thread trimmer (only for TW1-999L14D3T5-001)
O type Parameter		
O01	1~10(stitch)	Number of soft start stitches
O04	1~1000(millisecond)	Delay time for stitch for stitch backtrack. Refer to A20

O06	0~1	Automatic foot lifter release 1 = Automatic foot lifter release after the time of O07 0 = always hold
O07	5~30(second)	Refer to O06
O17	0~1	Refer to 5.5
O23	1~60(second)	The running time of aging test
O24	1~60(second)	The idle time of aging test
O25	1~720(hour)	The total time of aging test
O26	0~2	Set to "1/2" active the aging test
O31	0~1	Safety switch function 1 = open 0 = close
O32	0~1	Polarity of safety switch 0 = Normal closed 1 = Normal opened
O35	0~359	Angle of pull back after trimming
O48	0~100	The duty of clamp SOL
O51	0~1	Refer to 5.5
O56	0~4095	Pedal input MAX value: value \geq O57
O57	0~4095	Pedal input dividing value of high speed and low speed: O56 \geq value \geq O58
O58	0~4095	Pedal input dividing value of low speed and Balance: O57 \geq value \geq O59
O59	0~4095	Pedal input dividing value of Balance and Foot lifter: O58 \geq value \geq O60
O60	0~4095	Pedal input dividing value of Foot lifter and Trimming: O59 \geq value \geq O61
O61	0~4095	Pedal input MIN value: value \leq O60
O63	0~5	Pedal mode 0 = linear 1 = polyline 2 = curve(slow \rightarrow quick) 3 = curve(quick \rightarrow slow); 4 = S curve(slow \rightarrow quick \rightarrow slow) 5 = S curve(quick \rightarrow slow \rightarrow quick)
O64	500~5000	The speed of turning point when O63 set as 1
O65	0~4095	The value of turning point: O56 \geq value \geq O57
O69	0~1	Correction mode 0 = only the machine stopped 1 = before trimming
O83	0~720	Step width for electronic hand wheel
O84	0~200	Speed for electronic hand wheel
O91	1~10	Stitches of start with 2 nd stitch length

10.ERROE MESSAGES & POSSIBLE TROUBLESHOOTING

ERROE CODE	DESCRIPTION	SOLUTION
PEDAL	Pedal warning	<ul style="list-style-type: none"> - Check or replace the pedal - Pedal not connected - Do not pedal yet
CARE	Safe Switch problem	<ul style="list-style-type: none"> - Check the Safe Switch - Replace the safe switch
KEY1	Machine button warning	<ul style="list-style-type: none"> - Do not press machine button - Replace the buttons
E101	High AC voltage fault	<ul style="list-style-type: none"> - Check mains voltage - Stabilize mains voltage - Use generator
E103	High Bus voltage fault	<ul style="list-style-type: none"> - Check mains voltage - Stabilize mains voltage - Use generator
E106	Bus current overload	<ul style="list-style-type: none"> - Check the encoder and motor - Replace the encoder - Replace the motor
E107	Motor blocked	<ul style="list-style-type: none"> - Eliminate stiff movement in the machine - Replace the encoder - Replace the motor
E110	Encoder/Synchronizer fault	<ul style="list-style-type: none"> - check or replace the synchronizer for a belt-drive machine - check or replace the encoder for a direct-drive machine
E190, E290	Software Update Error	<ul style="list-style-type: none"> - Software update - Replace the control
E191, E291	Software Update Error	<ul style="list-style-type: none"> - Software update - Replace the control
E193, E293	Software Update Error	<ul style="list-style-type: none"> - Software update - Replace the control
E294	Software Update Communication Error	<ul style="list-style-type: none"> - Software update - Replace the control
E199	Software Update Error	<ul style="list-style-type: none"> - Software update - Replace the control
E900	Communication problem	<ul style="list-style-type: none"> - Restart the control - Replace the control

11.Controller Check

Press hold **S** during power on, it will display "TEST" and then enter the Check interface. Seven-Segment display A display check index, the else display contents.

11.1 Pedal

Display B,C shows the pedal position status, display D,E,F,G display sample value.

<i>bL</i>	Balance position
<i>L4</i>	Low-speed position, is stepping on the first paragraph
<i>H4</i>	High-speed position, is stepping on the second paragraph
<i>FP</i>	Foot position, anti-step on the first paragraph
<i>FN</i>	Trim position, anti-step on the second paragraph
<i>Er</i>	Not connected or the pedal is faulty

11.2 Synchronizer

Synchronizer: turning the motor, display C value changes from 0 to 1

Position encoder: turning the motor, display D E,F,G value changes between 0 to 720.

11.3 Keypad Test

Display B, C, D, E, F, G correspond to the six keys on keypad, when press the key,

the corresponding display will change from 0 to 1, press **+** to light on the

corresponding LED, press **-** to light off, **S** to light on all and **P** to light off all, the correspondence between the digital tube and the function key is as follows

Display B: foot stroke

Display C: start and end trips

Display D: position of the needle

Display E: stitch length

Display F: additional thread tension

Display G: pause

11.4 Motor encoder

11.5 Output Device

Digital F, G shows the current test solenoid type, the corresponding relationship is as follows

Solenoid	Display
Trimmer	<i>r</i>
Foot	<i>F₀</i>
Reverse	<i>rE</i>
Stroke	<i>4r</i>
Stitch length	<i>4L</i>
Clamp	<i>CL</i>
Main thread tension	<i>nr</i>
Additional thread tension	<i>Ar</i>
Seam middle guide	<i>nd</i>

Press  to test.

11.6 Input Switches

Display C: status of Reverse switch

Display E: status of Safety Switch

Display G: status of Knee Stroke Switch

11.7 Electronic Handwheel

Display B: Rotation

Display C: Press Switch

Display DEFG: Encoder

11.8 Speed Limit Device to stroke

Digital Type: four gears

- Display C shows gear, display E, G display the status of the two switches inside.

Analog Type: Stepless speed change

- Display D, E, F, G show the sample value of the potentiometer.
- Adjustment: press [P] to save two gear position, and press [S] to save six gear position.

11.9 AC voltage

Display the current AC input voltage

e.g: , AC voltage 220v.

11.10 Bus voltage

Display the current bus input voltage

e.g: , bus voltage 310v.

11.11 A phase current sampling reference

11.12 B phase current sampling reference

11.13 AD1 sample value

11.14 AD2 sample value

11.15 AD3 sample value

11.16 AD4 sample value

11.17 Main MCU Software Version

E.g: , version 1.00

11.18 Software Release Date

E.g: , released on October 1, 2016

11.19 Slave MCU Software Version

E.g: , version 1.00

12. Appendix

12.1 Seven-Segment Display Characters Compare Table

0	1	2	3	4	5	6	7	8	9
---	---	---	---	---	---	---	---	---	---

0	1	2	3	4	5	6	7	8	9
A	B	C	D	E	F	G	H	I	J
A	b	C	d	E	F	G	H	I	J
K	L	M	N	O	P	Q	R	S	T
t	L	n	n	o	P	q	r	r	r
U	V	W	X	Y	Z				
U	v	B		H	E				

12.2 How to update the control box with the update module

User can update software of the control box by update module if necessary, the operations showed as below

- Switch off the power, plug the update module into speed controller



- Switch on the power, upgrading starts automatically, it will be accomplished after "ALL OK" displayed. Then switch off and plug the speed controller, all function will be normal after switch on again.