



**TYPICAL**

**GC20606-D2**  
**GC20606-1-D2**

**2/1- Needle Compound Feed Lockstitch  
Sewing Machine With Automatic Thread Trimmer**

**OPERATION INSTRUCTION / PARTS MANUAL**

- Please don't adjust and repair the machine by non-professionals, except adjusting stitch.
- Specifications subject to change without notice

**TYPICAL SEWING MACHINE WANPING MACHINERY CO.,LTD.**

---

ADD: WANPING TOWN, WUJIANG CITY, JIANGSU  
PROVINCE, CHINA

TEL: +86-512-63391278

FAX: +86-512-63391371

POST. CODE: 215223

[Http://www.typicalwpchina.com](http://www.typicalwpchina.com)

E-mail:[export@typicalwpchina.com](mailto:export@typicalwpchina.com)

## 1. Brief Introduction

The models adopt double (single) needle and two (single) vertical hooks with auto lubrication for thread looping, sliding lever for thread take up to form two lines of lockstitch seam. The upper shaft and lower shaft are supported by ball bearing and driven by teeth-type synchronic belt; plunge oil pump lubrication system. They adopt the compound feed mechanism of feed dog, needle bar and presser foot, even if for long stitch length and long material. This series can deal with them freely. This series adopts numerical computerized control system, which is designed with auto-trimming, auto-setting stitich length, auto-backtacking, auto-presser foot lifter, etc. It is also designed with the electrical servo motor.

This series is widely used in the factories of suitcase, tent, cushion, leather, goods, apparel, mat, etc.

## 3. Installation and preparation

### 3.1 Installation

#### 3.1.1 Location of the machine

To ensure a smooth running, the machine should be located on a rigid and flat floor. The insert of rubber mat between machine stand and floor is recommended for further reducing the running noise and vibration.

#### 3.1.2 Installing the oil reservoir (Fig.1)

Put the oil reservoir into the table cutout, and place the four cushions on the four corners of the cutout, then set the cushions and oil reservoir in the table.

#### 3.1.3 Installing the machine head (Fig.2)

Set the hinge A onto the hinge socket B on the table, then turn the machine head freely until it is seated on the frame of table cutout

## 2. Main specifications

Model	GC20606-D2	GC20606-1-D2
Specifications		
Application	Medium and heavy duty	
Max.sewing speed	1800spm	
Max.stitch length	9mm	
Presser foot lift volume	8mm by hand, 13mm by knee	
Needle bar stroke	36mm	
Rotating hook	Large vertical hook with auto-lubrication	
Needle	DP 17 Nm125-180	
Needle gauge	6.4mm (standard)	
Lubrication	Auto lubrication (partial of manually oiling)	
Motor	Servo motor 550W	

★.Optional gauge size:3.2、 4、 4.8、 8、 9.5、 12.7、 16、 19、 25.4mm

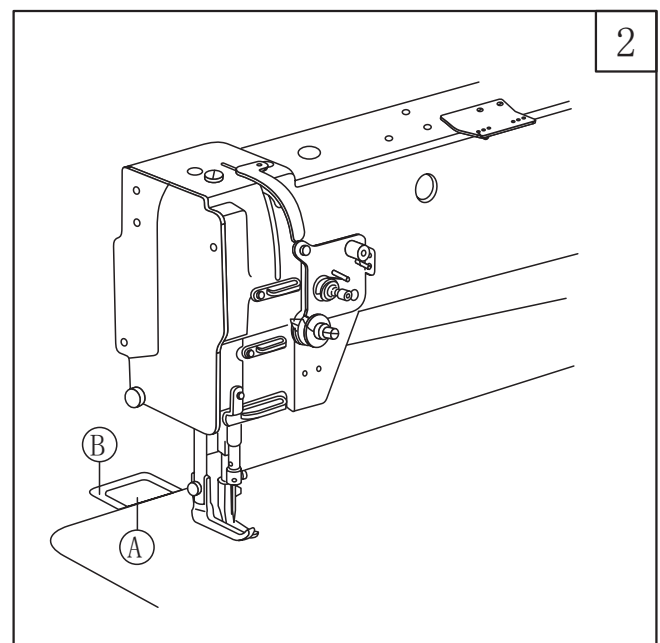
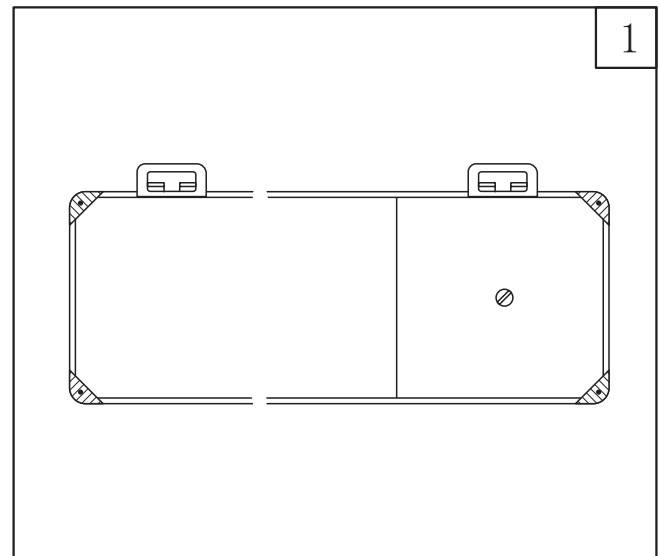

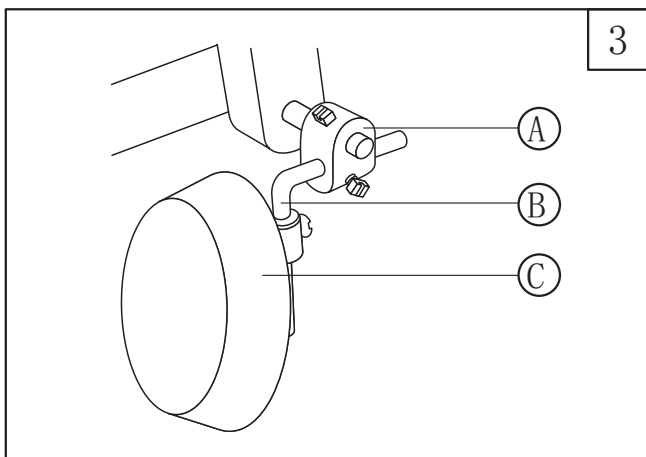

### 3.1.4 Knee control presser foot lifter installation (Fig.3)

#### a. Installation

Install the Connector A, Bell crank B, Bell C in the order shown in Fig.3.

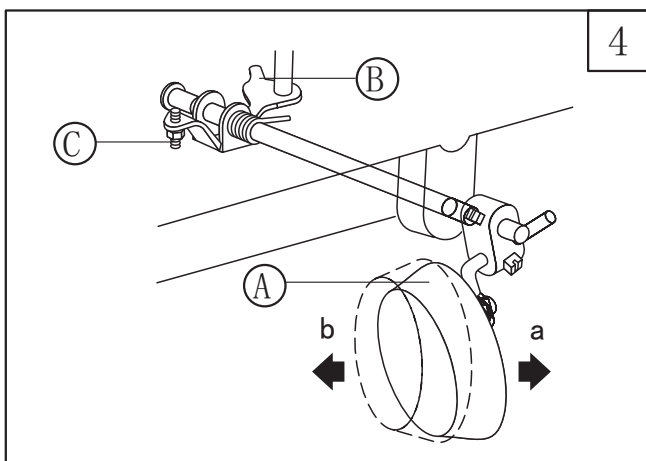

#### B. Adjustment (Fig.4)

1. When the presser foot is at its lowest position, keep the crank in the position shown by b in the figure; turn the knee control stop adjusting screw C to touch with the oil reservoir, and tighten the nut of screw C.

2. When it is operated by knee, the presser foot lift volume is controlled by screw B. Turn the presser foot down, make the bell in the position shown in the figure, lift the presser foot to 13mm, adjust the screw B to touch with the oil reservoir, then tighten the nut of screw B.

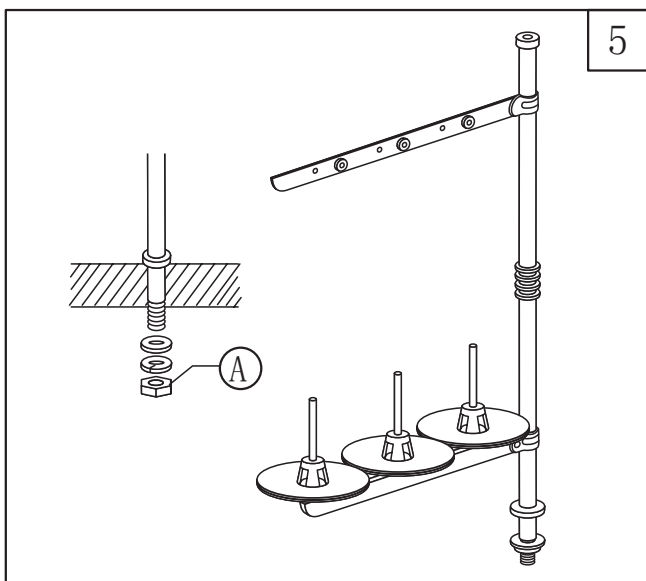

### 3.1.5 Installing the thread spool stand (Fig.5)

Locate the thread spool stand at the right front of the table, note that spool rest may not obstruct when machine head is turned backward, then tighten the nut A.

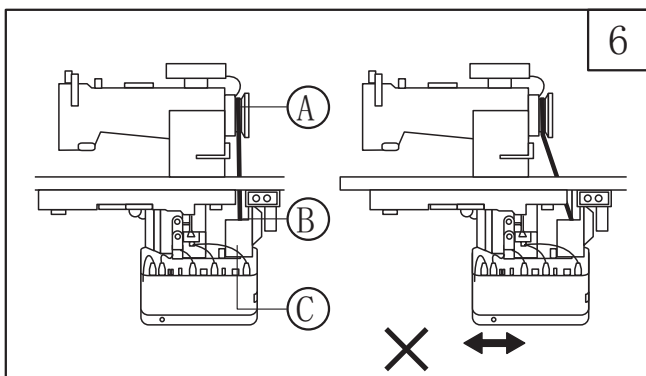

### 3.1.6 Installing the motor (Fig.6)

Align the machine balance wheel belt groove A with motor pulley belt groove B by moving the motor C leftward and rightward. Be sure the belt is not touch with table.

### 3.1.7 Connecting the clutch lever to the pedal (Fig.7)

- a. The optimum tilt angle of pedal with floor is 20~30 degree.
- b. Adjust the clutch of the motor so that clutch lever C and draw bar B run in line.
- c. The machine balance wheel should rotate counter clockwise for normal sewing when view from the opposite side of balance wheel G. The motor is rotated in the same direction. The rotation can be reversed by reversing the plug of motor (turn over 180 deg.).
- d. Adjust the tension of V-belt F by moving the motor vertically. The proper tension of V-belt is a slack of 10-12mm when the belt is depressed at the belt pan by finger.

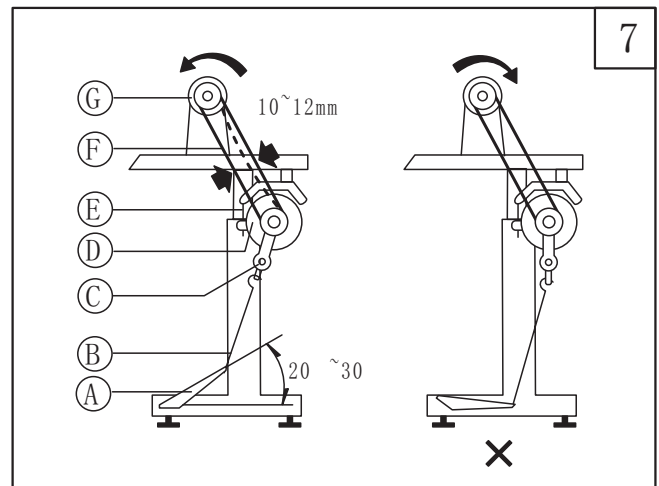

### 3.1.8 Installing the bobbin winder (Fig.8)

Align the pulley B of bobbin winder with outside of belt C and should be kept a proper clearance between them, so that pulley B could be contacted with belt after the stop latch thumb lever A depressed. Thereby belt drives the pulley B while machine running. After check bobbin winder is in parallel with belt slit E of table, fastened by two wood screws D.

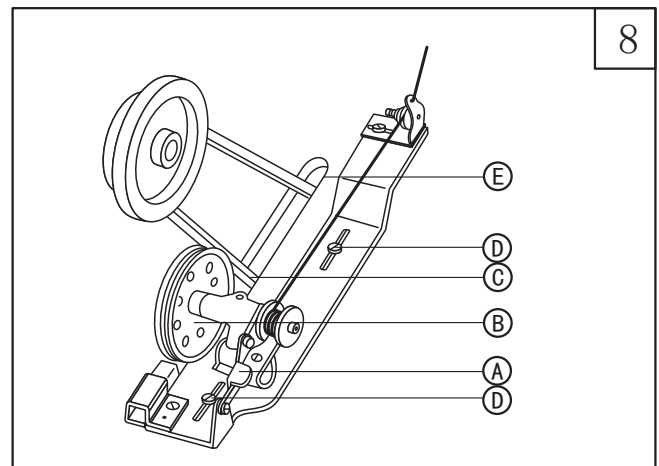

## 3.2 Preparation

### 3.2.1 Cleaning the machine

Before delivery, the machine parts are coated with rust preventive grease, which may be hardened and contaminated by dust during storage and shipment. The grease must be removed by clean cloth with gasoline.

### 3.2.2 Examination

Though every machine is confirmed by strict inspection and test before delivery, the machine parts may be loosed or deformed after long distance transportation after cleaning the machine. Turn the balance wheel to see if there is running obstruction, parts collision, uneven resistance or abnormal noise. If these exist, adjustment must be made accordingly before run.

### 3.2.3 Precaution

#### a. Oiling (Fig.9)

Oil amount should be filled according to the marks in the oil reservoir. Mark H refers to the highest of oil amount; L refers to the lowest. Note that the oil level should not lower than Mark L. Otherwise, the machine parts can not be fed with oil and will cause overheat and collision.

Be sure to use machine oil HA-8 or HJ-7.

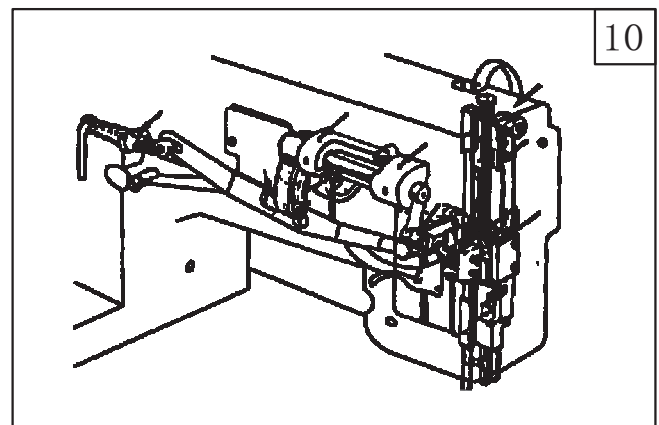
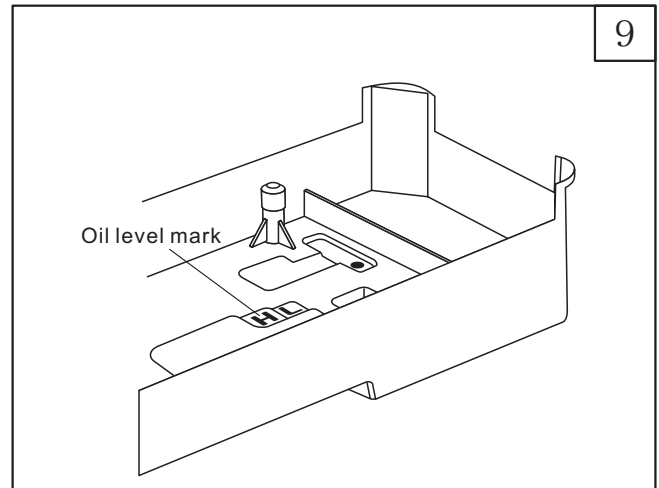

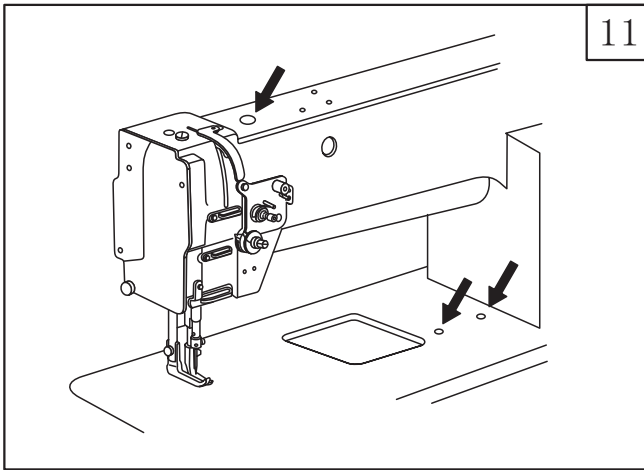

11

b. When the machine starts for the initial time or reuse after a long period of time, the proper oil amount should be filled in sections of machine shown by arrows in Fig 10,11. When it is in operation, observe the oil sparking in oil screen to check the oil condition (Fig.12).

c. When a new machine starts running, for extending its life, please run the machine at a low and medium speed (1000spm) for about a month and then raise the speed gradually.

d. Please turn off the power when it is not in use or the operator leaves away from it.

e. Replace the oil every month. When replacing, fully drain off the old oil in the reservoir and add the new one.

f. The needle gauge options are: 6.4, 3.2, 4, 4.8, 8, 9.5, 12.7, 16, 19, 25.4mm. For getting it, the needle plate, presser foot or alternating foot, needle folder, feed dog, left and right sliding plate, thread guide should be changed. It is provided with 6.4 mm when it leaves off the factory. For the other size, the relevant parts can be ordered from the factory.

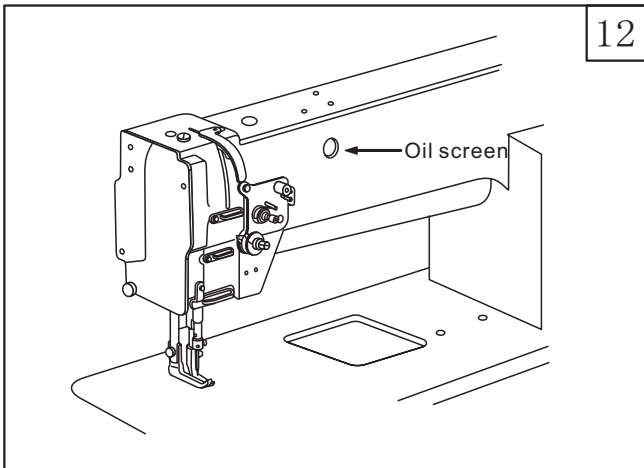

12

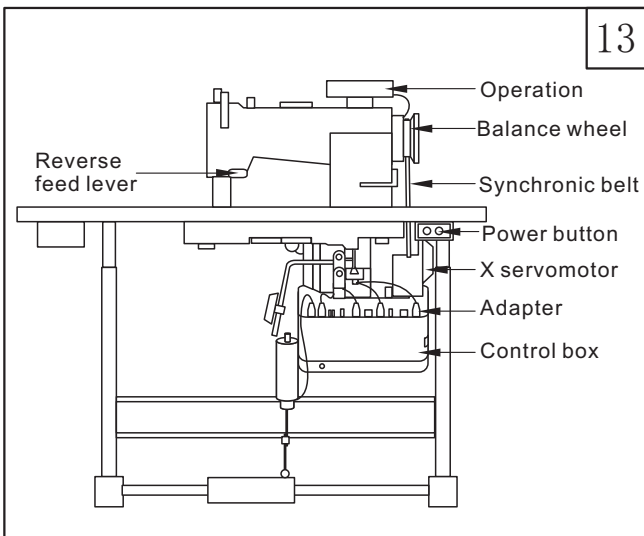

13

## 4. Operation

### 4.1 Connecting the power lead

#### 4.1.1 Connecting the power lead

When connecting the power lead to control box, be sure to confirm the plug model and the matching direction, then insert the plug into the jack.

If it is three phase power, Connecting "U" to red wire, "V" to white wire., "W" to black wire. The running direction of the motor depends on the switch in the control box.

Note: green wire must be connected to the ground wire to ensure the motor is connecting to earth.

The capacity of fuse: 200V~240V 10A  
120V~120V 15A

#### 4.1.2 Illuminating line

a. When installing the illuminating lamp (6V,10~15W), cut off the outside insulating tube of the connector, which is at the back of the control box, then make the connection, finally wind some friction tape on the connector.

Note: Turn off the power when installing the illuminating lamp.

b. When the illuminating lamp is not in use, the right side of the lead should take the insulation process as shown in Fig.14. If it fails, the control box may be burned out.

#### 4.3 Running direction

Open the rubber cover on the bottom of the left front of the control box, then press down the direction button to change the running direction of the motor.

When facing the pulley wheel, and the running direction is counter-clockwise, the indicator light on the switch is directing to "off"; on the contrary, to "on". Before delivery, the running direction of the pulley should be set as counter-clockwise.

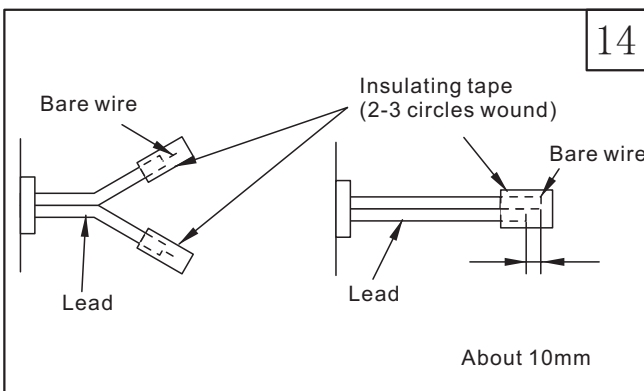

14

#### 4.2 Connecting the control box (Fig.15)

Note:

4.2.1 When connecting or removing the connector, turn off the power to ensure safety.

4.2.2 The model must match with the control box of the motor.

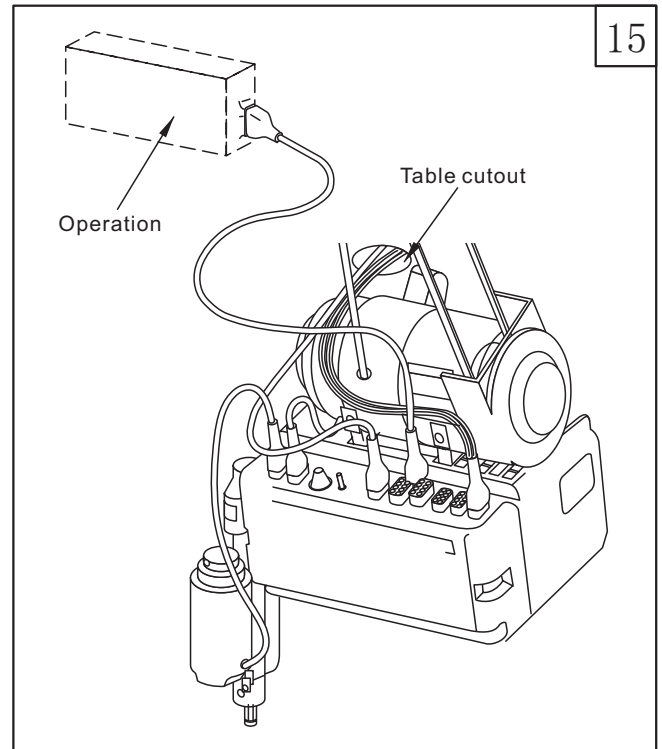

#### 4.3 Adjusting the stop position of the needle (Fig.16, 17)

##### 4.3.1 Adjusting the position of "UP"

When the pedal is depressed by foot, the machine should stop at the position of "UP". If it exceeds more than 3mm, adjustment should be done as follows:

Remove the power plug from the machine;

Run the machine to make it stop at the position of "UP";

Fix the pulley belt and insert the adjusting tool into Hole A to adjust the reflecting plate.

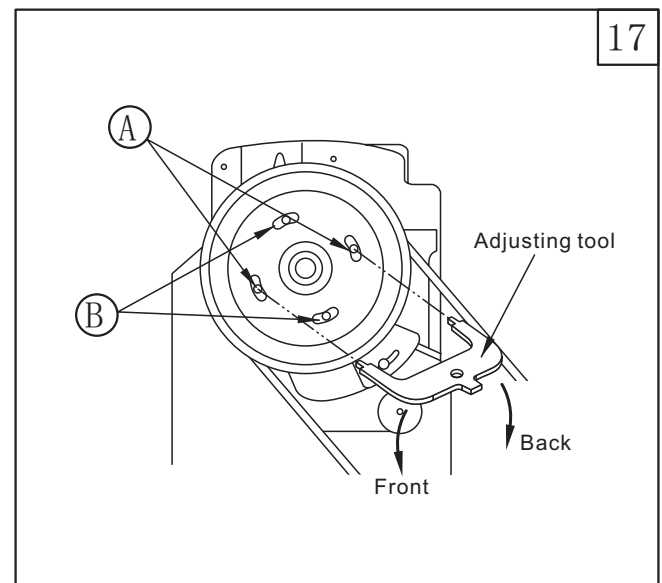
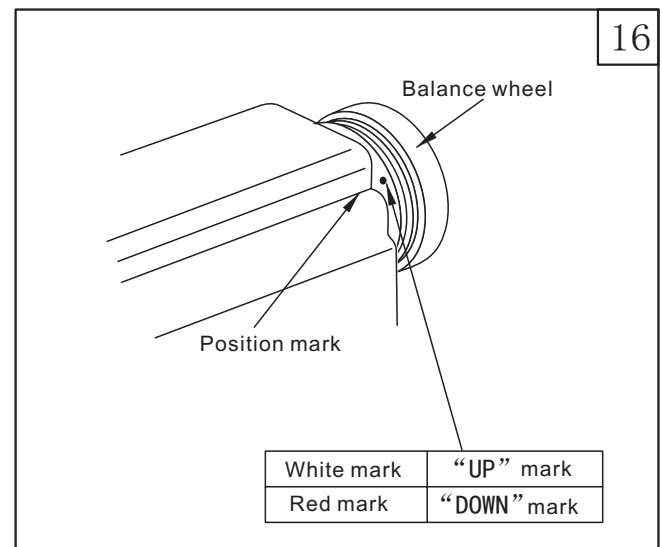



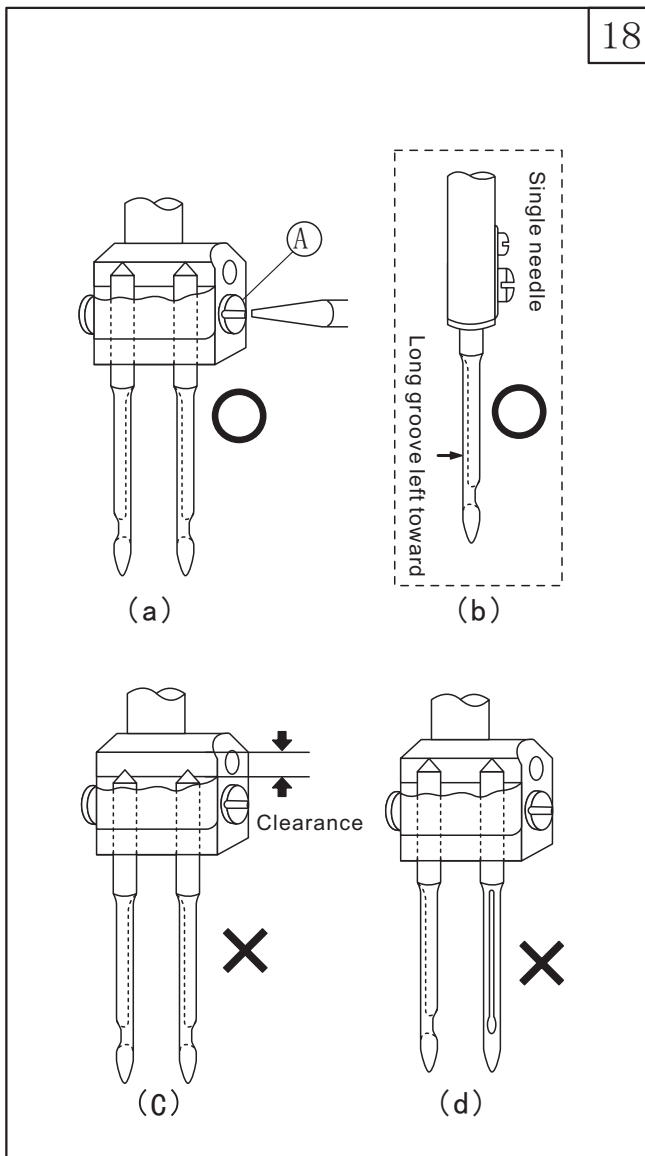

**4.4 Coordination between needle, thread and sewing material**  
 Please apply needle DP 17, Nm125-180. The coarseness of needle should be in accordance with the nature of material. If stitch on heavy duty material with a slim needle, the needle will be easily bent. Skip or thread breakage may also occur. On the contrary, stitch on tightly woven material with a very coarse needle, the material will be destroyed with over-big needle hole. So the needle and thread should be properly selected.

#### 4.5 Installing the needle (Fig.18)

Turn the balance wheel to lift the needle bar to its highest position, loosen needle set screw A, fully insert the needle shank into the bottom of the needle socket. Keep the long grooves of the two needles opposite to each other, then tighten the screw A. (Fig.18.a) For single needle, keep the long groove toward the left side of the operator as shown in Fig.18.b.

Note: Fig.c: insufficient insertion.

Fig.d: wrong direction

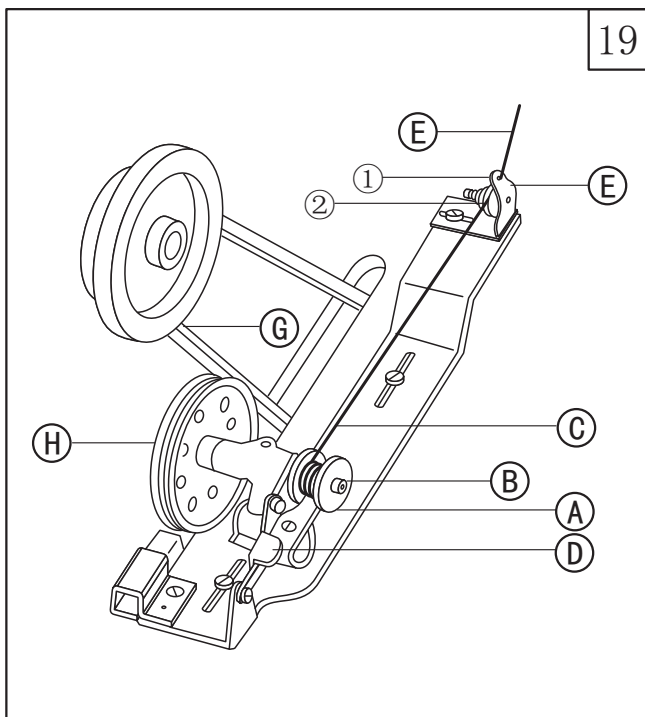

#### 4.6 Winding the bobbin thread (Fig.19)

- 1) Install the bobbin A to the bobbin winder spindle B.
- 2) Pass thread C from spool through the eye 1 on tension bracket E. Pass it between tension discs 2, and then wind the end of the thread a few turns on the bobbin.
- 3) Push stop latch thumb lever D down to lock the bobbin, the winder pulley F is thereby a few turns on the bobbin G.
- 4) Start the machine to wind thread.
- 5) When thread is fully wound, the bobbin winder stop latch automatically release the bobbin winder, thus stopping the winding motion.



**4.7 Threading (Fig.20)**

The thread should be drawn through thread hole A, when light and smooth thread (polyester or long silk thread) is applied, it should be drawn through hole B. Keep the thread take-up lever at its highest position, draw the thread in numerical order.

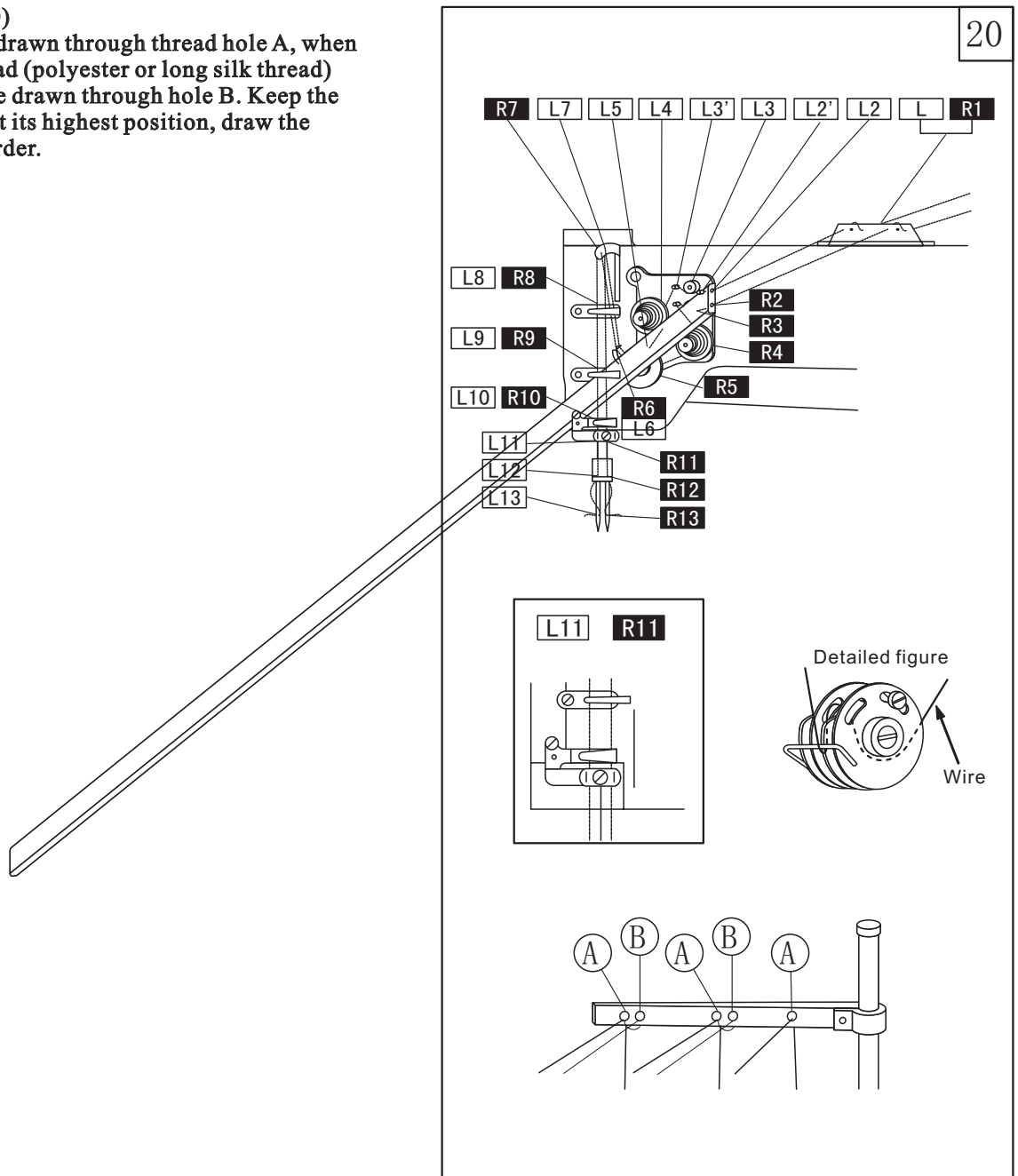

**4.8 Stitch length (Fig.21)**

The stitch length can be regulated by stitch length dial A. Turn it counter clockwise to expand its length; turn it clockwise to shorten its stitch length. The figures on dial A shows the sizes of the stitch length in mm. When reverse feed is required, press down the feed lever B to perform reverse sewing. Release the lever, the reverse feed lever can reset automatically and the forward sewing is resumed.

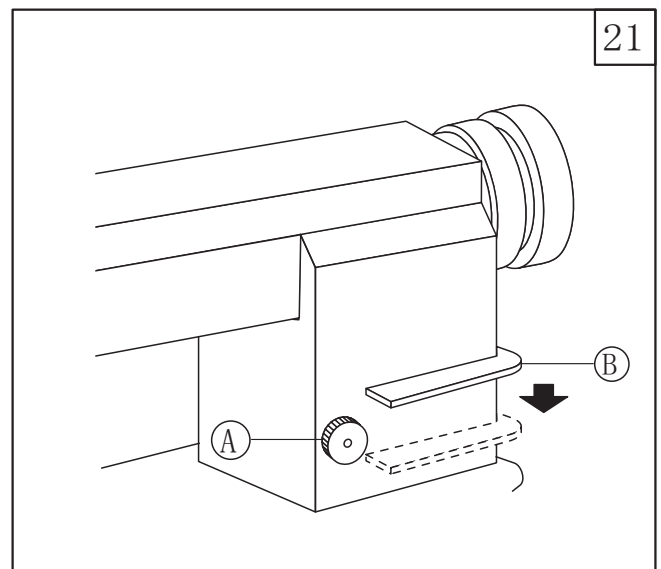

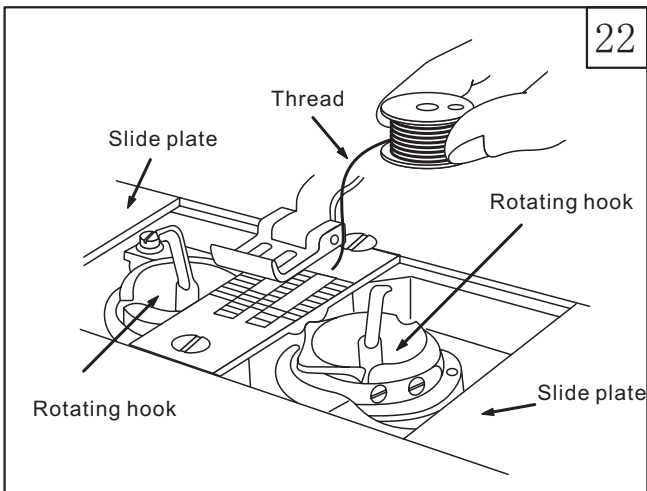

#### 4.9 Installing the bobbin (Fig.22)

Note: when the bobbin is installed into the bobbin case, the thread should be wound properly in the correct direction shown in the figure.

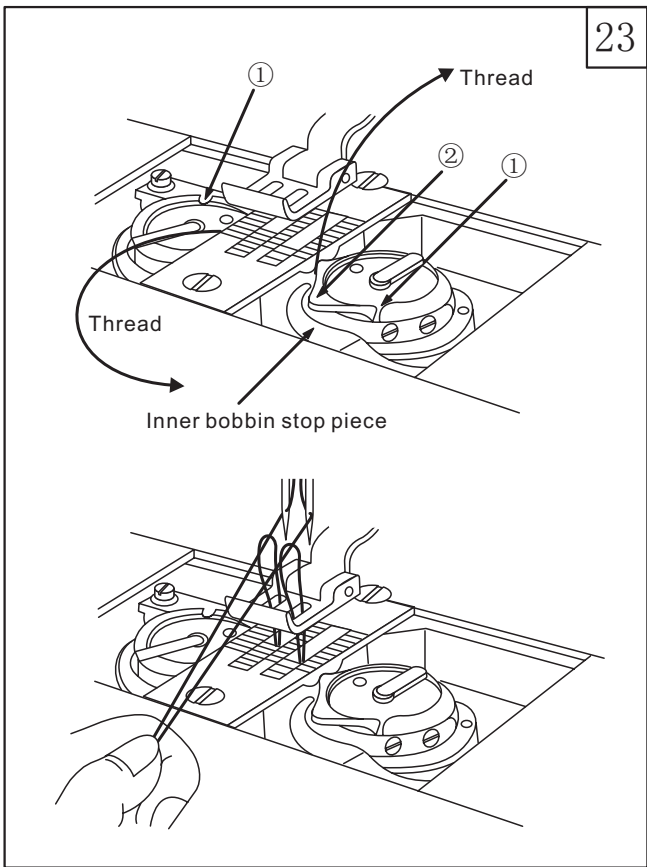

#### 4.10 Threading the bobbin thread (Fig.23)

a. Draw the thread tip to the bobbin slot 1 shown in the figure, and pull it out down through the inner bobbin stop piece.

b. Hold the tip of the thread with left hand, turn the balance wheel slowly and get the bobbin thread, then draw it a little apart from the presser foot.

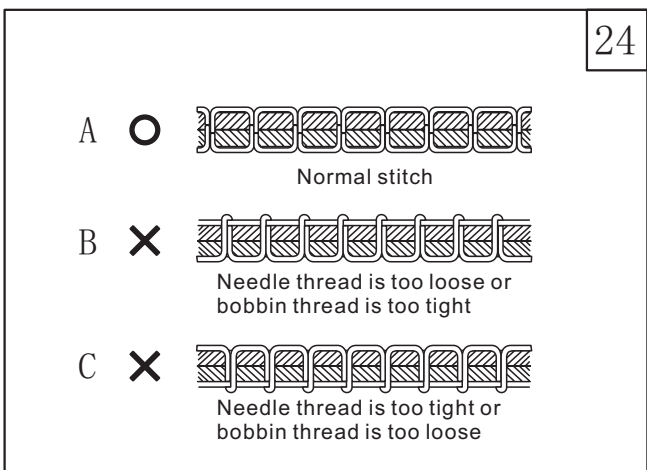

## 5. Machine adjustment

### 5.1 Thread tension adjustment

All forms of stitches are shown in Fig.20.

The normal stitch of sewing machine is shown as Fig.A. If stitch is abnormal, the puckering and thread breakage will occur, and the needle thread tension and bobbin thread tension should be adjusted so that the normal stitch can be obtained.

a.If the stiich form is the same as shown in Fig.24b, it indicates that the needle thread is too tight or the bobbin thread is too loose. Turn the thread tension screw counter clockwise to release the needle thread tension, or turn the adjusting screw with a screwdriver to increase the bobbin thread tension (Fig.25,26).

b.If the needle thread is too loose and the bobbin thread is too tight as shown in Fig,24c, turn the thread tension screw clockwise to increase the needle thread tension, or loosen the bobbin lace screw to reduce the bobbin thread tension.(Fig.25,26).

For special sewing with special thread, the required tension can be obtained by adjusting the strength and stroke of the thread take-up spring.

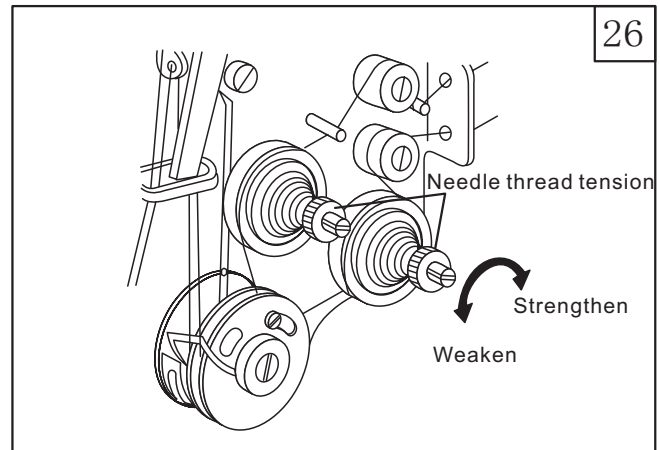
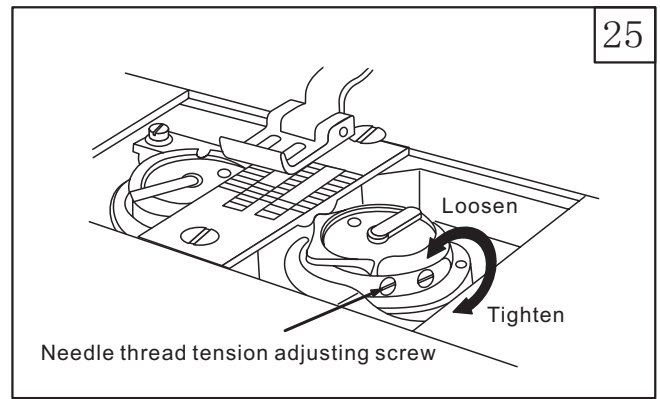

### 5.2 Adjusting the pressure of the presser foot (Fig.27)

The pressure of the presser foot should be adjusted according to the thickness of the sewing materials. If stitch on heavy duty materials, the pressure should be increased by turning the pressure adjusting screw on the back of the arm clockwise. To reduce the pressure, turn it counter-clockwise.

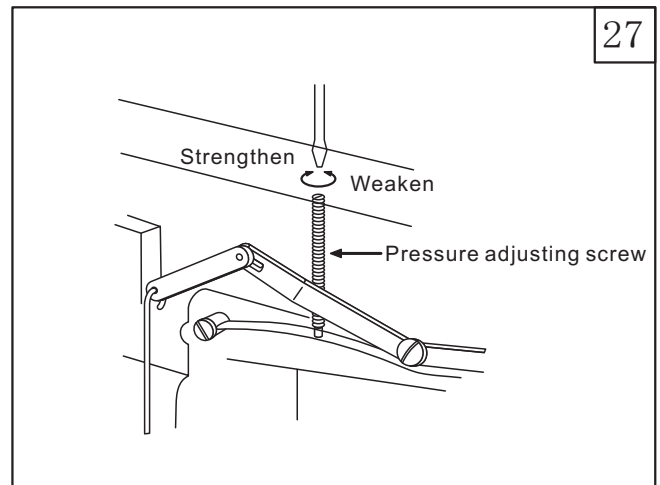

### 5.3 Safety clutch device

The safety clutch device is to prevent the hook and teeth-belt from destroy when the needle thread is drawn into the hook for abnormal load during the operation.

#### 5.3.1 Function of the safety clutch device (Fig.28)

a. When the safety clutch device is working, the teeth-belt will remove the load. The rock shaft stops rotating., only the upper shaft rotates, then the machine stops work.

b. Clean off the needle thread which is drawn in the hook.  
c. Turn the shaft of the teeth-belt with hand to check if the rock shaft can turn smoothly, then reset the safety clutch device.

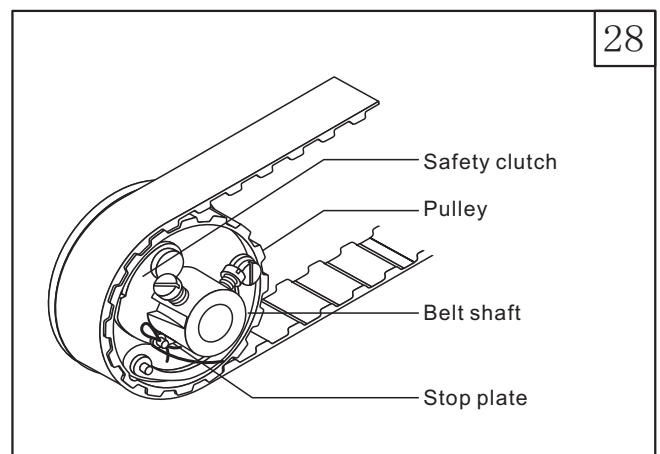

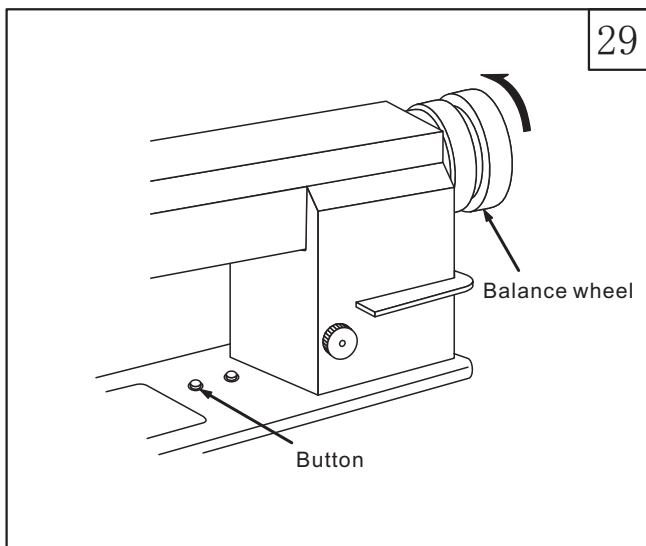

### 5.3.2 Resetting the safety clutch device

- a. While pressing down the button in the bed surface with left hand, turn the balance wheel slowly with right hand in the direction shown in Fig.29.
- b. When the stop plate stops the balance wheel, more strength is required to turn the balance wheel to reset the safety clutch device.
- c. Release the button. Then the resetting is OK.

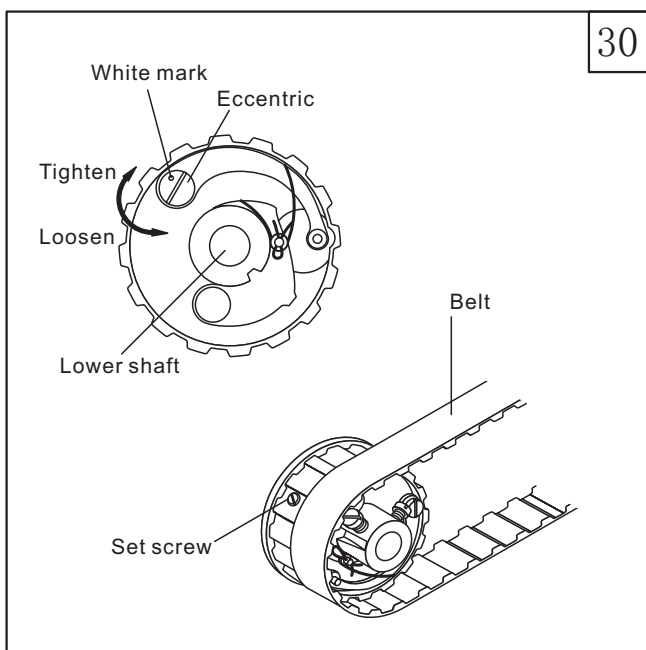

### 5.3.3 Adjusting the strength on the safety clutch device (Fig.30)

- a. When the white mark of the eccentric pin aims at the center of the rock shaft, it indicates that the strength on the safety clutch device is at the minimum. When the white mark points the outside, the strength is properly increased.
- b. To regulate the strength of it, move the teeth-belt and loosen the set screw of the eccentric pin, then turn the eccentric pin.
- c. After adjustment, please tighten the set screw.

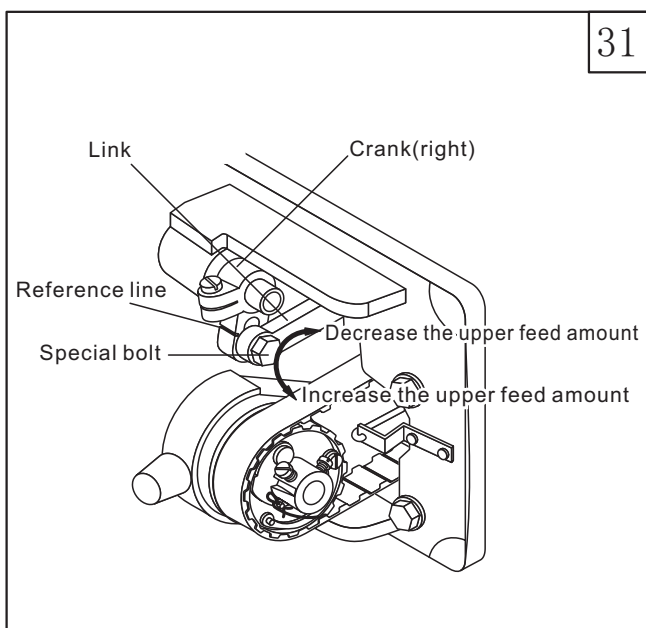

### 5.3.4 Upper feed adjustment (Fig.31)

- If the upper and lower feed are not in timing during sewing, the long hole of the horizontal feed crank should be adjusted to get the length of the upper feed. Adjust as follows:
- Loosen the special bolt;
  - Move the special bolt upward to reduce upper feed amount;
  - Move the special bolt downward to increase the feed amount. Theoretically, when it is on the reference line of the horizontal feed crank, the upper feed amount equals to the lower feed amount;
  - After adjustment, tighten the special bolt.

### 5.3.5 Presser foot lift volume adjustment (Fig.32)

When stitch on the very elastic material or the thickness of the sewing material is changed. The adjustment should be done in the following order:

Loosen the special bolt;

When the centerline distance between the special bolt and the presser foot lift rear crank is decreased, the presser foot lift volume will be increased. On the contrary, the distance is increased, the lift volume will be decreased.

After adjustment, tighten the special bolt. The common presser foot lift volume can be adjusted in the range of 2-6mm.

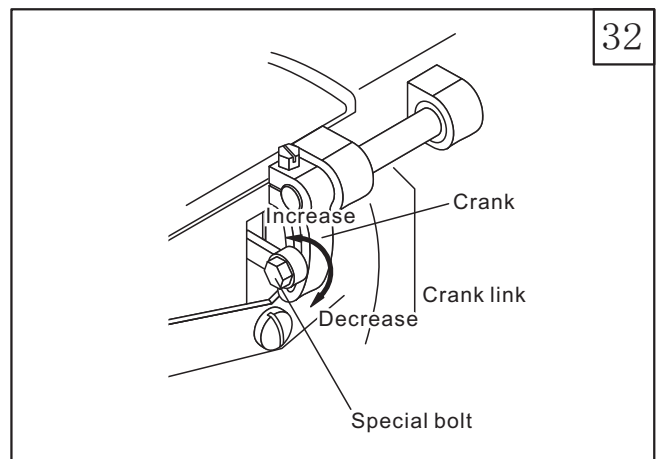

### 5.3.6 Hook oil amount adjustment (Fig.33)

It adopts plunger full auto-lubrication system. Even when run at a low speed, it can supply and suck oil very well. Generally, only the hook oil amount can be adjusted. It can be obtained by the oil amount adjusting screw. Loosen the nut of the adjusting screw, turn the screw clockwise to increase the oil amount. On the contrary, to reduce the oil amount. After adjustment, tighten the nut.

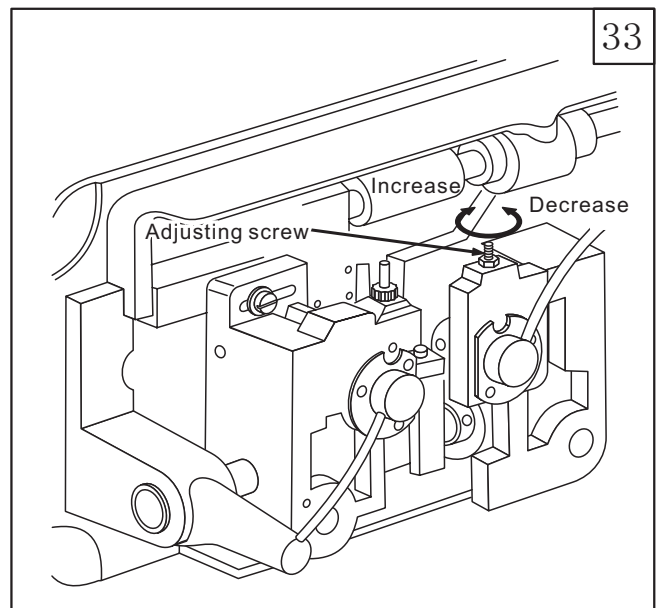

### 5.4 The movable knife

#### 5.4.1 Set the movable knife's original position (Fig.34)

- Turn the balance wheel to lower the needle bar to its lowest position.
- Move the trimming driven crank to make the trimming roller get into the trimming cam groove.
- Turn the balance wheel until the white mark on the balance wheel is aligned with the mark line. Then primarily set it as the position of the trimming driven crank. Tighten the concerning screws temporarily to prevent the trimming roller sliding out from the trimming cam groove.
- Loosen the screw A, B.
- Adjust the movable knife to obtain the clearance of 0-0.5mm between the terminal line of the movable life and the front end of the fixed knife. Then tighten the screw A, B.

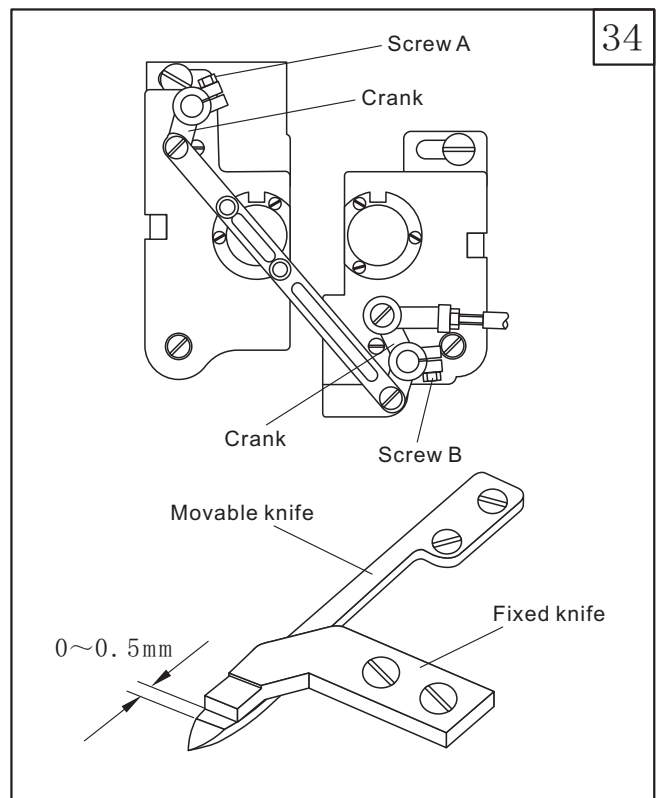



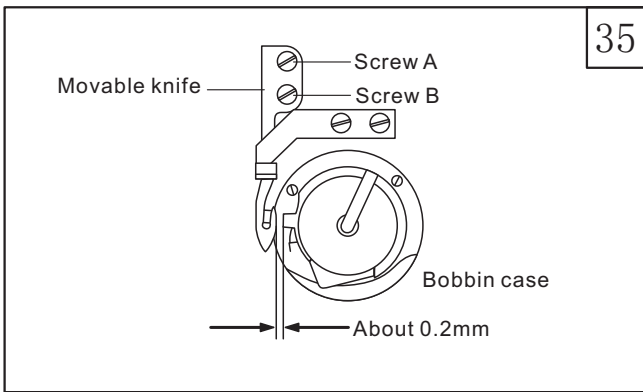

#### 5.4.2 Adjusting the clearance between the movable knife and the rotating hook position block. (Fig.35)

- Turn the balance wheel to lower the needle bar to its lowest position.
- Press down the trimming driven crank and turn the balance wheel, so that the movable knife can go forward as far as it can go.
- Turn the inner rotating hook by hand to adjust the clearance between the movable knife and bobbin case position block to 0.2mm. (Loosen the screw A, B before adjusting.)

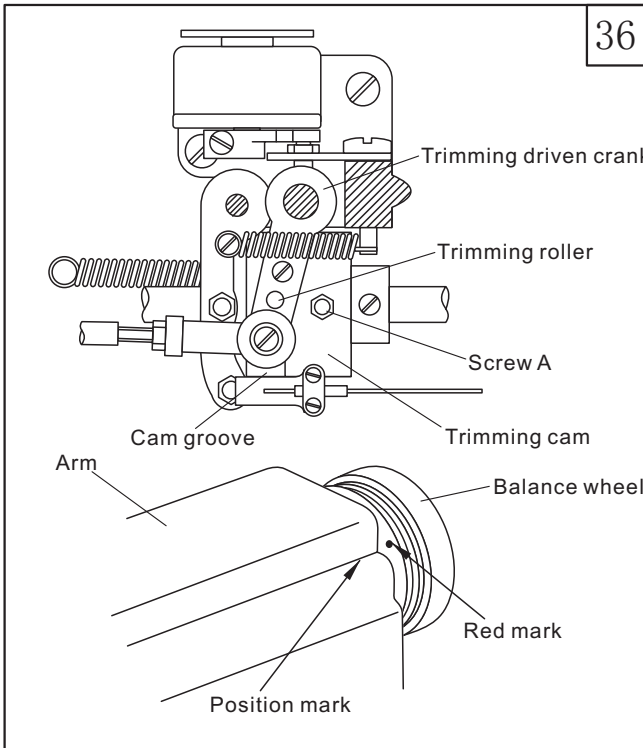

#### 5.5 Adjusting the trimming cam (Fig.36)

- Turn the balance wheel to lower the needle bar to its lowest position.
- Maintain the position of needle bar, press down the trimming driven crank, so that the trimming roller can get into the trimming cam groove.
- Turn the balance wheel, adjust the trimming cam to make the white mark on the balance wheel align with the position mark line on the arm, then the movable knife starts working. (Loosen the two set screws A on the trimming cam before adjusting.)

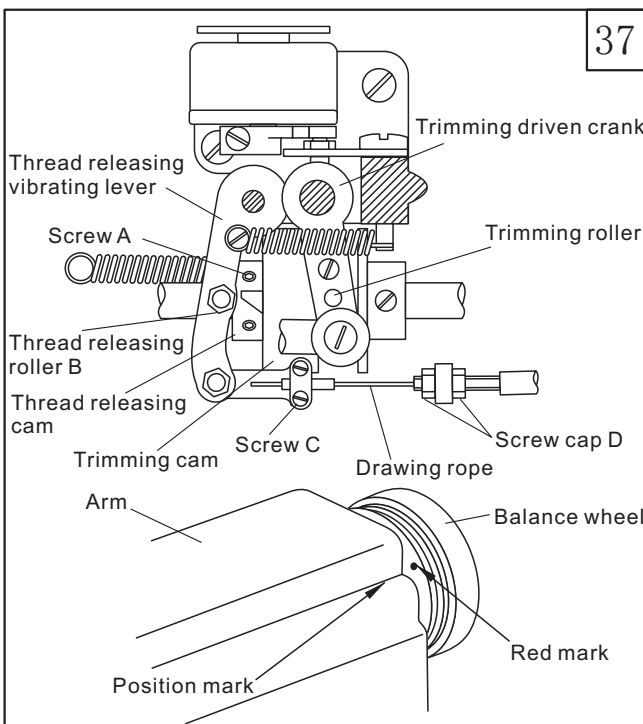

#### 5.6 Adjusting the thread releasing assembly (Fig.37)

- Turn the balance wheel to lower the needle bar to its lowest position.
- Maintain the position of needle bar, press down the trimming driven crank, so that the trimming roller can get into the trimming cam groove.
- Turn the balance wheel, adjust the trimming cam to make the white mark on the balance wheel align with the position mark line on the arm, then the Thread tension disc is closed. (Loosen the screws A on the threading releasing cam before adjusting.)

Adjusting the open range of the thread tension disc by the thread releasing roller B and thread releasing cam. When adjusting, loosen the adjusting screw C, and shrink the drawing rope.

When carrying out the fine adjustment, loosen the screw cap D, move the outside cover of the drawing rope rightward to enlarge the open range of the thread tension disc.

### 5.7 Adjusting the trimming pressure of the movable knife and fixed knife (Fig.38)

a. Loosen the set screw A.

b. Turn the adjusting screw B to adjust the trimming tension between the movable knife and the fixed knife. After adjustment, tighten the screw A.

Note: If there is too much trimming tension between the movable knife and the fixed knife, it will cause strong movement and trimming failure. Therefore, the minimum trimming tension is required.

Move the movable knife to make sure that if it can cut the thread sharply.

When it can not cut the thread sharply, polish the fixed knife as shown in the Fig.39 and replace the movable knife for a new one.

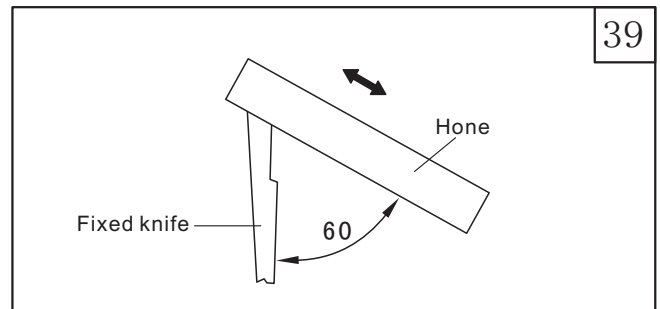
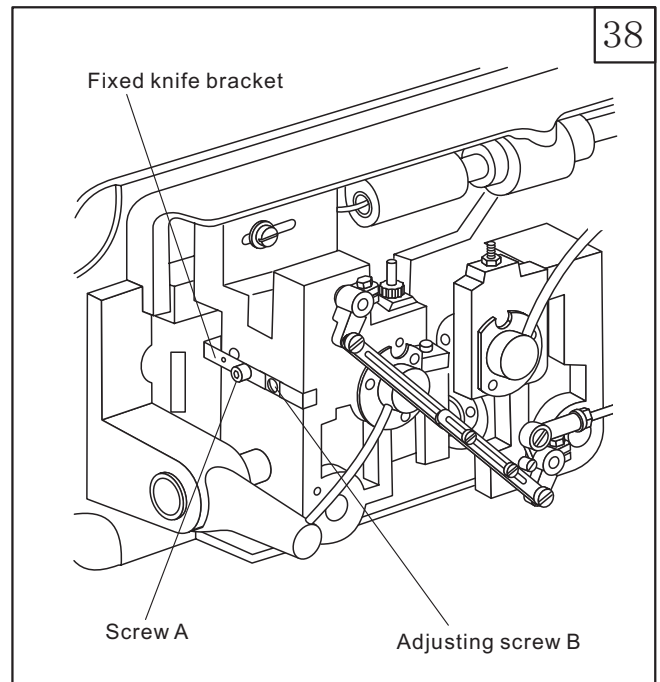

### 5.8 Adjusting the needle gauge (Fig.40)

a. Uninstall the needle plate, feed dog and the needle clamp.

b. Tilt back the machine head.

c. Loosen the two screws J.

d. Take down the spring M.

e. Loosen the rotating hook screws A, B. And adjust the clearance between the rotating hook and the needle.

f. Install the spring M.

g. When the crank C, D is close to position screw E, F, tighten the screw J.

h. Turn the balance wheel to lower the needle bar to its lowest position.

i. Loosen the screw cap G, H.

j. Press down the trimming driven crank K, adjust the trimming link L, so that the trimming roller is able to get into the trimming cam groove.

k. Adjusting the trimming cam and the trimming roller.

1) Press down the trimming driven crank K so that the trimming roller is able to get into the trimming cam groove.

2) Turn the trimming link L, adjust the clearance between the trimming roller and trimming cam groove N to its minimum, then tighten the screw G, H.

3) Press down the trimming driven crank K again, and check that if the trimming roller is able to get into the trimming cam groove smoothly.

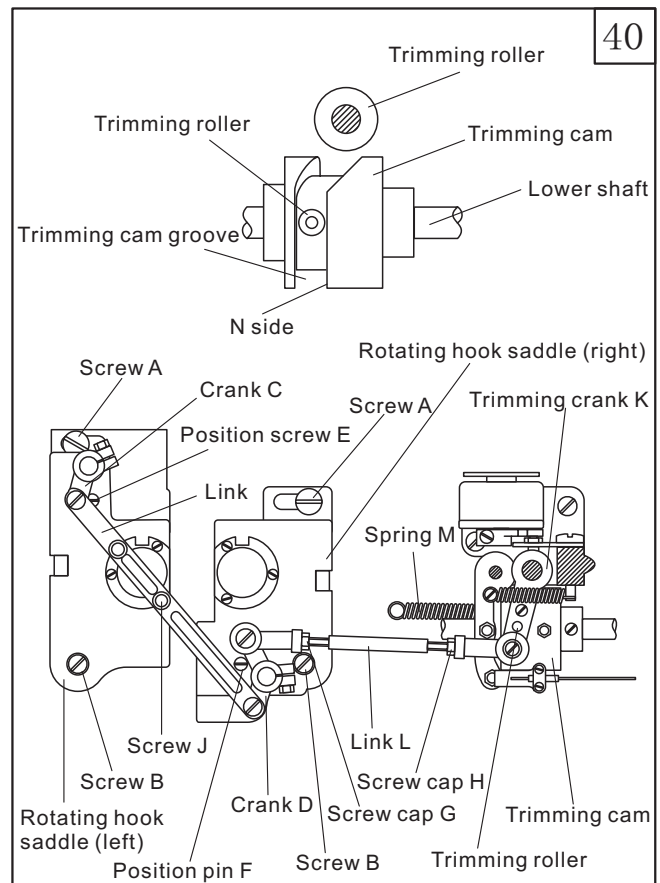



# 1. Arm parts

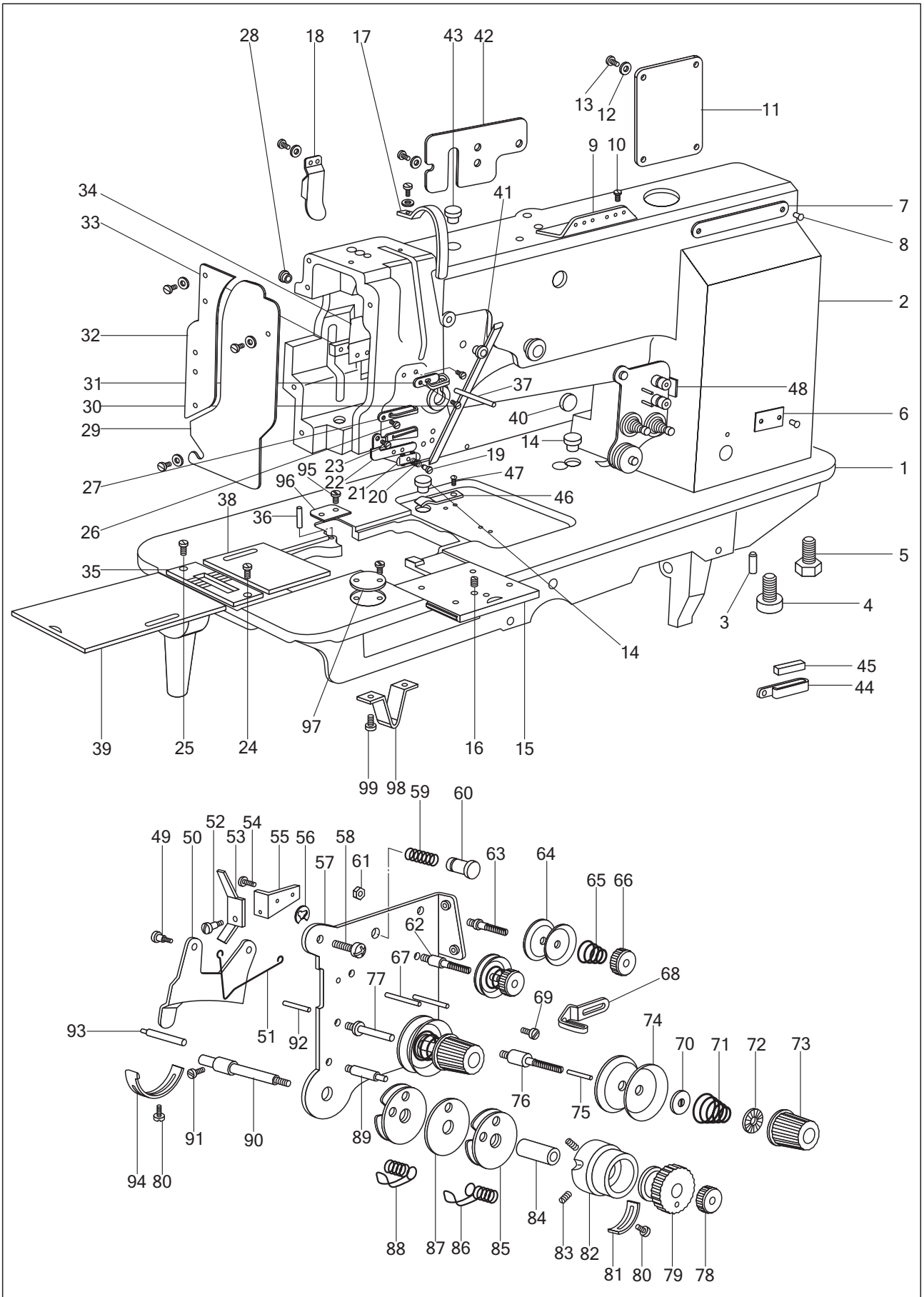

## 1. Arm parts

No.	Part Number	Name	Qt.		Remark
			GC20606-D2	GC20606-1-D2	
1	84WF1-003	Bed	/	1	
	83WF1-004		1	/	
2	84WF1-004	Arm	1	1	
3		Pin	2	2	A6 3 0 GB117-86
4		Screw	1	1	M10 35 GB70-85
5		Screw	3	3	M10 35 GB5781-85
6	84WF1-001A	Trade mark (in Chinese)	/	1	
	84WF1-001B	Trade mark (in English)	/	1	
	83WF1-001A		1	/	
	83WF1-001B		1	/	
7	84WF1-002A	Model plate (in Chinese)	/	1	
	84WF1-002B	Model plate (in English)	/	1	
	83WF1-002A		1	/	
	84WF1-002B		1	/	
8		Nail	4	4	Φ2.5 5 GB827-86
9	1WF1-015	Upper thread guide	1	1	
10	1WF1-016	Screw	2	2	SM11/64" 40/8
11	1WF1-017	Rear cover	1	1	
12	1WF1-011	Screw	15	15	SM11/64" 40/9
13	22T1-007	Washer	15	15	
14	1WF1-032	Cover	2	2	
15	1WF1-038	Front slide plate	1	/	
16	1WF1-039	Screw	1	/	SM11/64" 32/5.4
17	1WF1-019	Thread take-up lever guard	1	1	
18	1WF1-030	Back front cover	1	1	
19	1WF1-027	Screw	1	/	
20	1WF1-028	Spring	1	/	
21	1WF1-003	Thread retainer	1	/	
22	1WF1-004	Lower thread finger	1	/	
23	1WF1-005	Screw	1	1	SM9/64" 40/6.5
24	1WF1-034	Screw	1	2	
25	1WF1-036	Screw	1	1	SM11/64" 40
26	1WF1-007	Screw	1	1	SM9/64" 40
27	1WF1-006	Middle thread finger	1	1	
28	1WF1-018	Rubber plug	2	1	
29	1WF1-013	Face plate	1	1	
30	1WF1-009	Screw	2	2	SM3/16" 28
31	1WF1-008	Upper thread finger	1	1	
32	1WF1-012	Guide set plate	1	1	
33	1WF1-021	Set plate	1	1	
34	1WF1-020	Oil retainer	1	1	
35	83WF1-016	Needle plate	1	/	
	84WF1-017	Needle plate	/	1	
36	1WF1-037	Pin shaft	1	/	
37	84WF1-026	Thread releasing shaft	1	1	
38	84WF1-024	Right sliding plate	1	1	
39	83WF1-019	Left sliding plate	1	/	
	1WF1-040	Left sliding plate	/	1	
40	1WF1-029	Rubber plug	1	1	
41	1WF1-022	Rubber plug	1	1	
42	1WF1-031	Cover	1	1	
43	1WF1-014	Rubber plug	1	1	
44	9WF1-001	Lower thread finger	1	1	
45	9WF1-002	Oil felt	1	1	

# 1. Arm parts

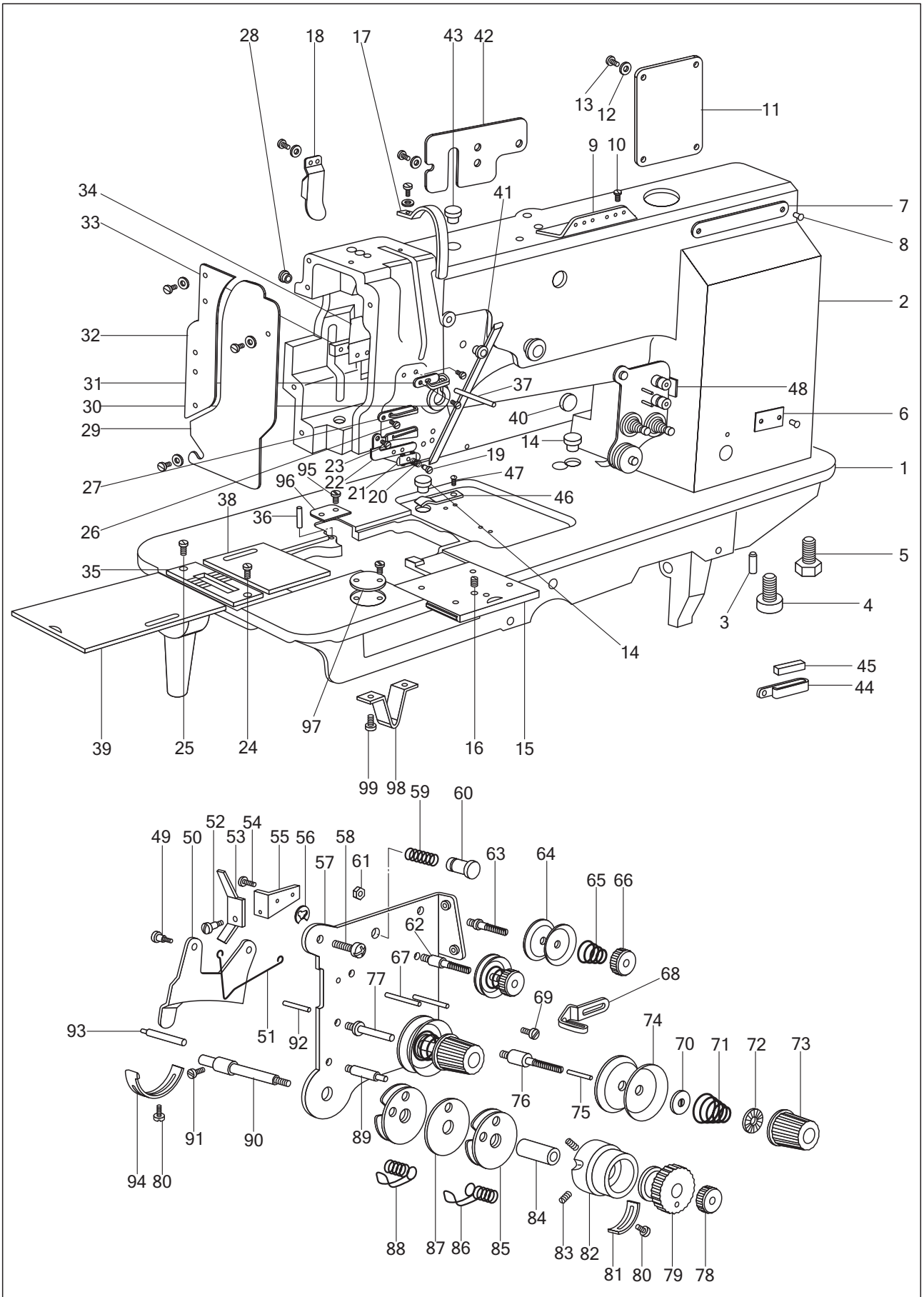

## 1. Arm parts

No.	Part Number	Name	Qt.		Remark
			GC20606-D2	GC20606-1-D2	
46	1WF1-043	Spring retaining plate	1	1	
47	22T2-004	Screw	1	1	
48	84WF1-027	Thread tension assembly	/	1	
	83WF1-005	Thread tension assembly	1	/	
49	1WF1-010Q	Screw	2	2	
50	84WF1-010	Thread releasing erecting plate	1	1	
51	84WF1-010P	Spring	1	1	
52	84WF1-012	Screw	1	1	
53	84WF1-011	Thread releasing vibrating lever	1	1	
54	84WF1-014	Screw	1	1	
55	84WF1-013	Set plate	1	1	
56		Retainer	1	1	GB896-86-5
57	84WF1-005A	Set plate	1	1	
58	1WF1-011	Screw	1	1	
59	84WF1-016	Spring	1	1	
60	84WF1-015	Button	1	1	
61	13WF2-052	Nut	2	1	
62	84WF1-006	Bolt (long)	1	/	
63	13WF2-051	Bolt	1	1	
64	22T1-009E3	Thread tension disc	4	2	
65	13WF2-009	Spring	2	1	
66	36T2-006D4	Nut	2	1	
67	84WF1-005B	Pin	3	2	
68	84WF1-006	Thread guide	1	1	
69	1WF1-005	Screw	1	1	
70	27WF2-008C	Thread releasing plate	2	1	
71	27WF2-008B	Spring	2	1	
72	153209	Stop plate	2	1	
73	27WF2-008A	Thread tension nut assembly	2	1	
74	27WF2-008F	Thread tension plate	4	2	
75	1WF1-010M	Thread releasing stud (short)	1	/	
76	83WF1-005A	Thread tension bolt (right)	1	/	
77	84WF1-005C	Thread tension bolt (left)	1	1	
78	1WF1-010H	Nut	1	1	
79	83WF1-011	Bushing	1	1	
80	1WF1-026	Screw	1	1	
81	21WF4-046	Position bracket	1	1	
82	83WF1-012	Guide cover	1	/	
83	83WF1-013	Screw	1	/	
84	84WF1-014	Bushing	1	/	
85	84WF1-001	Thread control assembly	2	1	
86	83WF1-010	Thread take-up spring	1	/	
87	83WF1-007	Thread guide plate	1	/	
88	9WF1-003B	Thread take-up spring	1	/	
89	83WF1-008	Position screw	1	/	
90	83WF1-009	Thread take-up spring shaft	/	1	
	84WF1-010	Thread take-up spring shaft	1	/	
91	1WF1-024	Screw	1	1	
92	1WF1-010L	Thread releasing stud (long)	1	1	
93	84WF1-026	Thread releasing lever	1	1	
94	1WF1-025	Position plate	1	1	
95	84WF3-003	Screw	6	2	
96	84WF1-018	Cover	/	1	
	83WF1-016	Cover	1	/	
97	83WF1-017	Round cover	1	/	
98	84WF1-019	Bed leg	1	1	
99	84WF1-020	Screw	1	1	



## 2. Upper shaft and presser foot parts

No.	Part Number	Name	Qt.		Remark
			GC20606-D2	GC20606-1-D2	
1	1WF2-025	Upper shaft	1	1	
2	1WF2-022	Front bushing	1	1	
3	1WF2-023	Screw	1	1	
4	1WF2-024	Oil felt	1	1	SM1/4" 24/13
5	1WF2-021	Needle bar crank	1	1	Felt
6	1WF2-020	Set screw	1	1	
7	1WF2-007	Position screw	1	1	SM9/32"/28
8	1WF2-010	Position screw	3	3	GB7-1
9	1WF2-009	Screw	1	1	SM1/4" 40/7
10	1WF5-026	Eccentric wheel	1	1	SM1/4" 40/4
11		Elastic retainer	1	1	
12	1WF5-041	Slide groove	1	1	φ25 GB894.1-86
13	1WF2-026	Retainer	3	3	
14	1WF2-030	Screw	3	3	
15	1WF2-029	Position screw	1	1	SM15/64" 28/8.5
16		Ball bearing	1	1	SM15/64" 28/15
17	1WF2-031	Rear bushing	1	1	
18	1WF2-019	Screw	2	2	
19	84WF2-001	Balance wheel	1	1	SM15/64" 28/12
20	1WF2-044	Screw	2	2	
21	1WF2-028	Synchronic belt	1	1	SM15/64" 28/4.5
22	1WF2-039	Spring plate	1	1	
23	1WF2-037	Pin	1	1	
24	1WF2-041	Spring	1	1	
25		Split retainer	1	1	
26	1WF2-040	Stop plate	1	1	φ3 GB896-86
27	1WF2-048	Stud	1	1	
28	1WF2-045	Retaining plate	1	1	
29	1WF2-042	Connecting piece	1	1	
30	1WF2-046	Bushing	1	1	
31	1WF2-047	Position screw	1	1	
32	1WF2-038	Set screw	1	1	SM15/64" 28/10.5
33	1WF5-001	Nut	1	1	SM15/64" 28/10
34	1WF5-025	Eccentric link	1	1	
35	1WF5-044	Connecting bolt	1	1	
36		Washer	1	1	
37	1WF5-023	Oil tube assembly	1	1	Washer 6 GB95-85
38	1WF5-024	Spring	1	1	
39	1WF5-045	Rear crank	1	1	
40	1WF4-018	Screw	3	3	
41	1WF5-038	Front crank	1	1	SM1/4" 24/16
42	1WF5-028	Screw	2	2	
43	1WF5-037	Bushing	2	2	SM1/4" 24/8
44	1WF5-030	Presser foot lifter link	1	1	
45	1WF5-029	Screw	1	1	
46	1WF5-032	Screw	1	1	
47	1WF5-033	Presser foot lifter swing plate	1	1	SM11/64" 40/6
48	1WF5-034	Ball shaft	1	1	
49	1WF5-035	Ball	1	1	
50		Washer	2	2	
51	1WF5-042	Screw	2	2	Washer 4 GB848-85
52	1WF2-027	Timing wheel	1	1	SM11/64" 40/10
53	1WF2-037	Timing wheel	1	1	
54	43WF3-004	Rotating shaft	1	1	
55	JO. 0. 40	Screw	2	2	
56	43WF2-003	Middle bushing	1	1	

### 3. Needle bar and lower feed parts

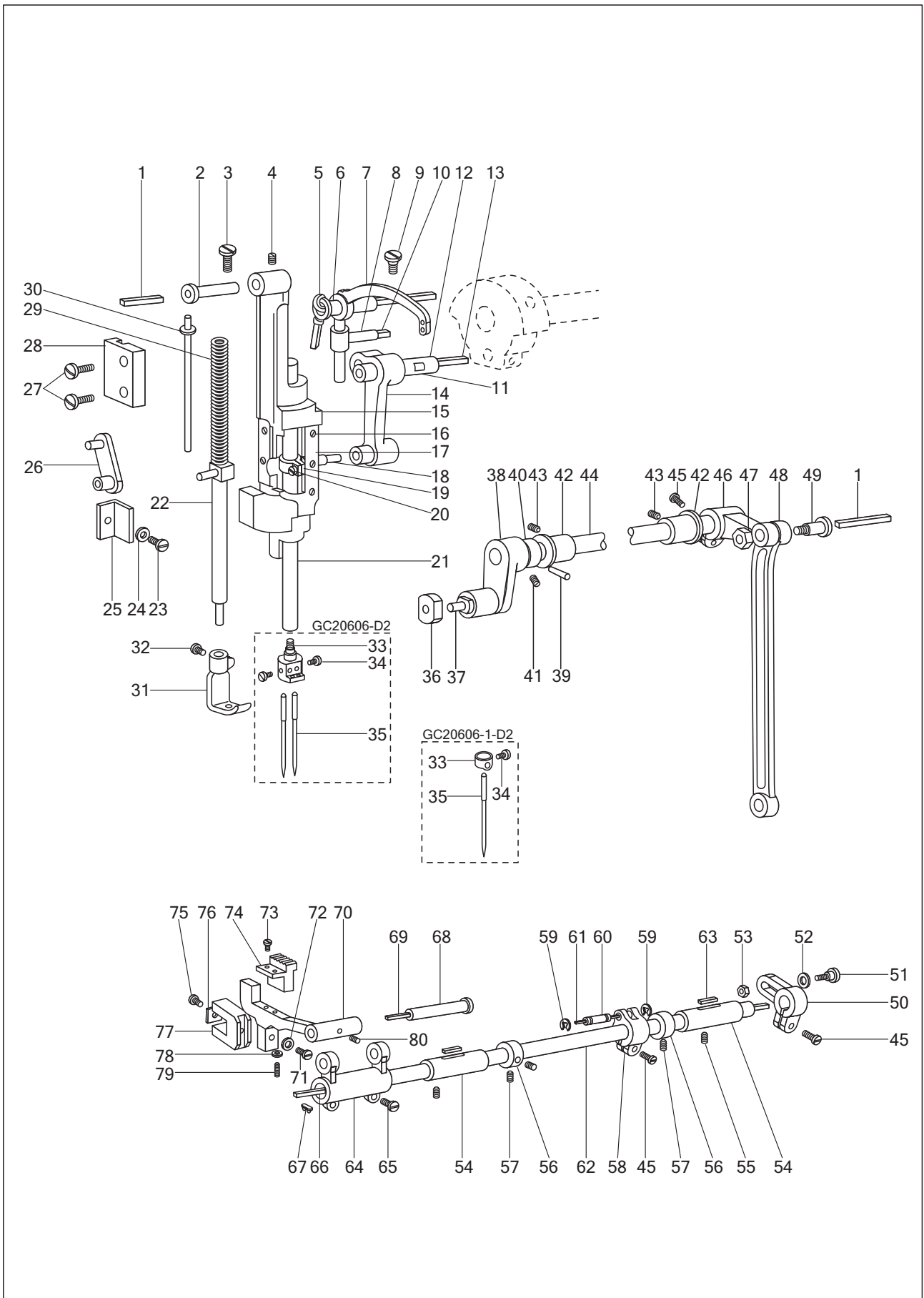



### 3. Needle bar and lower feed parts

No.	Part Number	Name	Qt.		Remark
			GC20606-D2	GC20606-1-D2	
1	1WF5-017	Oil wick	2	2	φ2.5 80 Cotton thread
2	1WF5-018	Shaft	1	1	
3	1WF5-031	Screw	1	1	SM5/16" 28/10
4	1WF5-019	Screw	1	1	SM15/64" 28/8
5	1WF2-018	Oil wick	1	1	φ2.5 240 Cotton thread
6	1WF2-017	Bushing	1	1	
7	1WF2-016	Thread take-up lever	1	1	
8	1WF2-011	Slide block	1	1	
9	1WF2-019	Screw	1	1	SM15/64" 28/12
10	1WF2-012	Oil wick	1	1	φ3 25
11	1WF2-013	Choke plug	1	1	
12	1WF2-014	Pin	1	1	
13	1WF2-015	Oil wick	1	1	φ3 80 Cotton thread
14	1WF2-008	Needle bar link	1	1	
15	1WF5-011	Needle bar vibrating bracket	1	1	
16	1WF5-013	Screw	6	6	SM3/32" 56/4.6
17	1WF5-012	Gasket	2	2	
18	1WF2-007	Oil felt	1	1	
19	1WF2-005	Needle bar adaptor	1	1	
20	1WF2-006	Screw	1	1	SM9/64" 40/8.5
21	1WF2-004	Needle bar	1	/	
	9WF2-001	Needle bar	/	1	
22	1WF2-006	Presser bar	1	1	
23	1WF5-010	Screw	1	1	SM11/64" 40/12
24		Washer	1	1	Washer GB848-85
25	1WF5-009	Needle bar holder guide plate	1	1	
26	1WF5-036	Presser bar link	1	1	
27	1WF3-009	Screw	2	2	SM11/64" 40/15
28	1WF5-014	Needle bar vibrating bracket guide plate	1	1	
29	1WF5-016	Spring	1	1	
30	1WF5-015	Spring reel	1	1	
31	1WF5-043	Walking presser foot	1	/	
	35T5-502	Walking presser foot	/	1	
32	22T2-004	Screw	1	1	
33	1WF2-003	Needle clamp	1	/	
	35T1-103	Needle bar thread guide	/	1	
34	1WF2-002	Screw	2	/	SM9/64" 40/4.3
	22T2-017	Screw	/	1	
35		Needle	2	2	DP 17 23#
36	1WF5-007	Slide block	1	1	
37	1WF5-008	Slide block groove	1	1	
38	1WF5-020	Left crank	1	1	
39		Pin	1	1	A4 24 GB117-86
40	1WF5-021	Washer	1	1	

### 3. Needle bar and lower feed parts

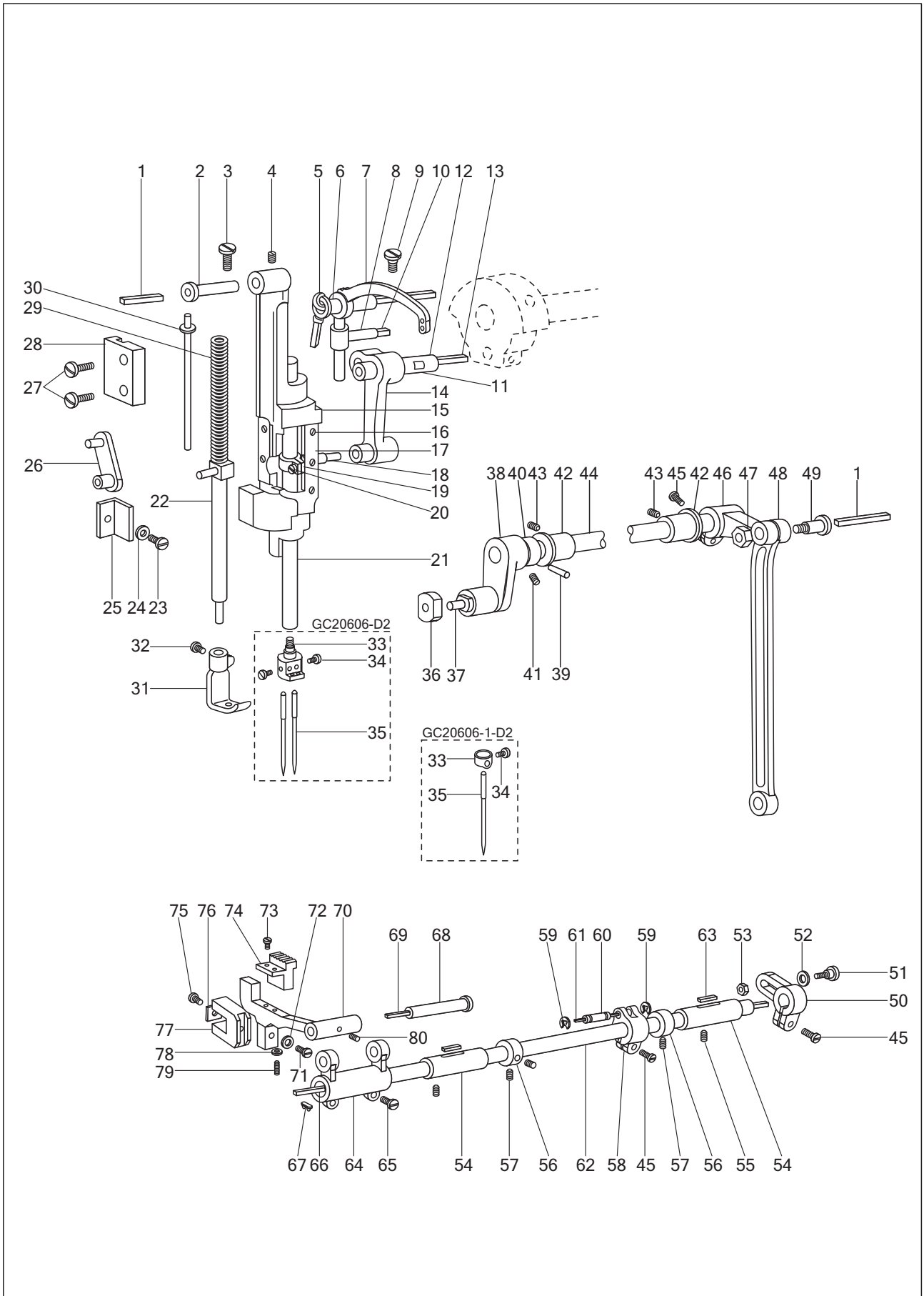

### 3. Needle bar and lower feed parts

No.	Part Number	Name	Qt.		Remark
			GC20606-D2	GC20606-1-D2	
41	1WF5-022	Screw	2	2	
42	1WF5-027	Bushing	2	2	
43	1WF5-028	Set screw	2	2	SM1/4" 24/8
44	1WF5-048	Needle bar vibrating shaft	1	1	
45	1WF4-018	Screw	3	3	
46	1WF5-005	Rear crank	1	1	
47	1WF5-004	Connecting nut	1	1	
48	1WF5-003	Link	1	1	
49	1WF5-049	Connecting screw	1	1	
50	1WF5-002	Right crank	1	1	
51	1WF5-046	Pin	1	1	
52	1WF5-047	Washer	1	1	
53	1WF5-001	Nut	1	1	
54	1WF4-052	Bushing	2	2	
55	1WF2-023	Set screw	2	2	
56	1WF4-054	Collar	2	2	
57	1WF2-009	Screw	4	4	SM1/4" 40/4
58	1WF1-017	Crank	1	1	
59		Split retainer	2	2	Retainer5 GB896-86
60	1WF4-019	Pin	1	1	
61	1WF4-020	Oil wick	1	1	φ3 55 Cotton thread
62	1WF4-037	Feed shaft	1	1	
63	1WF4-038	Oil felt	2	2	Felt
64	1WF4-035	Connecting crank (left)	1	1	
65	1WF4-034	Screw	2	2	SM3/16" 28/12
66	1WF4-030	Oil wick	1	1	φ2.5 430 Cotton thread
67	1WF4-029	Oil wick clamp	1	1	
68	1WF4-036	Shaft for feed dog support crank	1	1	
69	1WF4-031	Oil wick	1	1	
70	84WF5-001	Feed dog support	1	/	
	83WF4-001	Feed dog support	/	1	
71	1WF4-032	Connecting screw	1	1	SM15/64" 28/16
72		Washer	1	1	Washer 6 GB95-85
73	1WF4-005	Screw	2	2	SM1/8" 40/7
74	83WF4-002	Feed dog	1	/	
	84WF5-002	Feed dog	/	1	
75	1WF4-007	Screw	1	1	SM1/8" 44/4
76	1WF4-008	Oil felt	1	1	Felt
77	1WF4-009	Feed dog lift fork	1	1	
78	1WF4-002	Nut	1	1	
79	1WF4-003	Screw	1	1	SM1/8" 40/13.5
80	42WF2-010	Screw	1	1	SM11/64" 40/6

#### 4. Lower shaft and thread looping parts

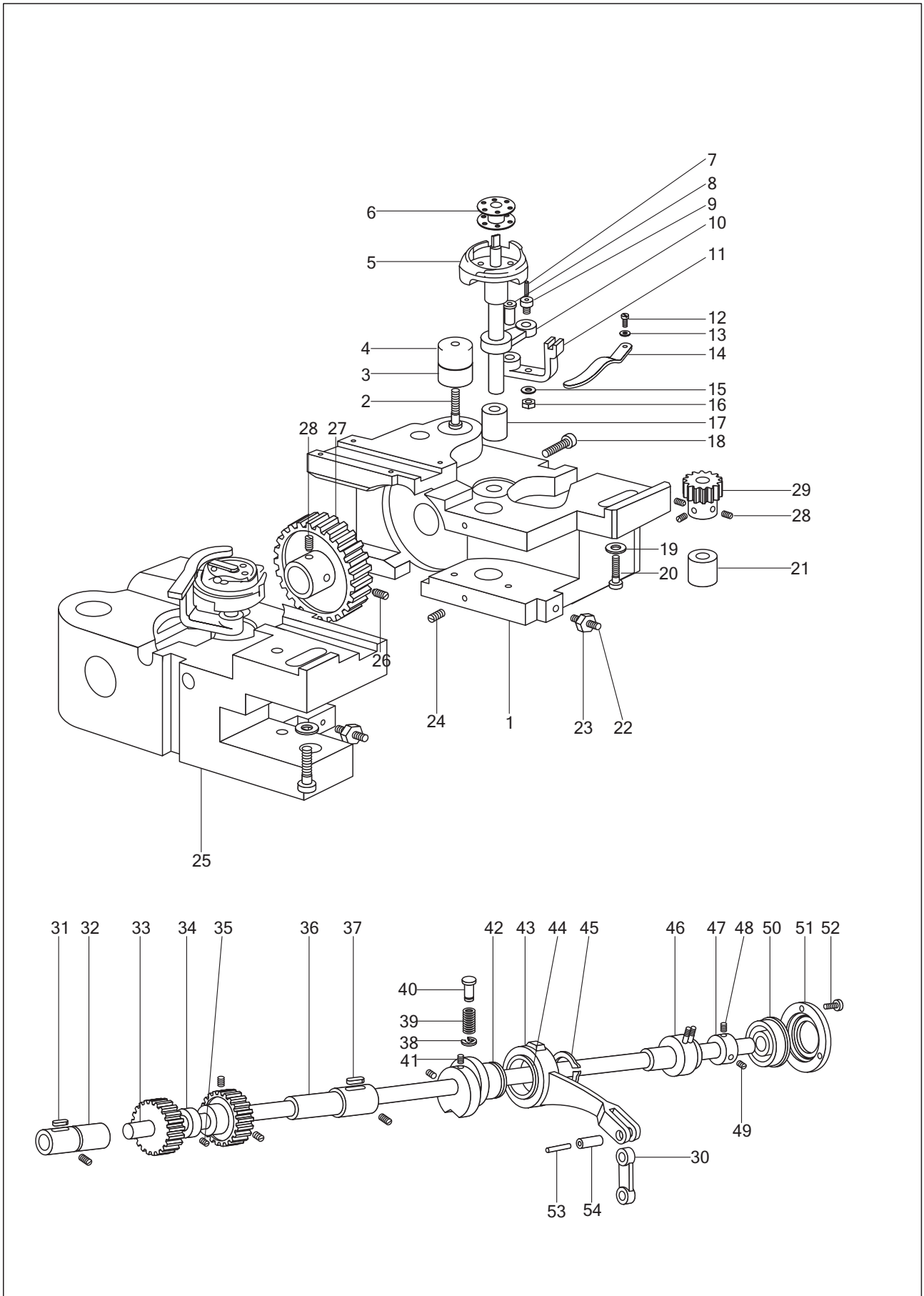

#### 4. Lower shaft and thread looping parts

No.	Part Number	Name	Qt.		Remark
			GC20606-D2	GC20606-1-D2	
1	84WF2-003	Right hook saddle	1	1	
2	1WF2-060	Screw	2	1	SM14/64" 28
3	1WF2-059	Upper bushing	2	1	
4	1WF2-061	Lower bushing	2	1	
5	84WF2-004	Rotating hook assembly	2	1	
6	1WF2-065	Bobbin	2	1	
7	1WF2-070	Oil wick	2	1	φ2.5 14 Cotton thread
8	1WF2-069	Hinge shaft	2	1	
9	1WF2-072	Screw	2	1	SM3/16" 32
10	84WF2-005	Connecting lever	2	1	
11	1WF2-075	Thread finger bracket	2	1	
12	1WF2-026	Screw	2	1	SM9/64" 40/4.5
13		Washer	2	1	Washer 4 GB848-85
14	1WF2-076	Thread finger	2	1	
15		Washer	2	1	Washer 4 GB848-85
16	1WF2-074	Nut	2	1	SM3/16" 32
17	1WF2-062	Bushing	2	1	
18	1WF2-034	Screw	2	1	SM3/16" 28/14.5
19		Washer	2	1	Washer 6 GB95-85
20	1WF2-033	Screw	2	1	SM1/4" 24/20
21	1WF2-077	Bushing	2	1	
22	1WF2-067	Nut	2	1	SM3/16" 28
23	1WF2-066	Screw	2	1	SM3/16" 28/25.5
24	1WF2-044	Screw	2	1	SM1/4" 40/5
25	83WF2-001	Left hook saddle	1	1	
26	1WF2-052	Screw	2	1	SM1/4" 40/4
27	1WF2-078	Spiral gear	2	1	
28	1WF2-009	Screw	8	4	
29	1WF2-079	Spiral gear	2	2	
30	1WF2-055	Feed link	1	1	
31	1WF2-035	Left bushing for lower shaft	1	1	
32	84WF2-002	Oil wick	1	1	φ25 45 Cotton thread
33	1WF2-056	Lower shaft	1	1	
34	84WF5-003	Feed dog lift cam	1	1	
35	1WF2-019	Screw	1	1	SM15/64" 28/12
36	1WF2-057	Right bushing for lower shaft	1	1	
37	1WF2-058	Oil wick	1	1	φ2.5 85 Cotton thread
38		Retainer	1	1	Washer 5 GB896-86
39	1WF4-041	Spring	1	1	
40	1WF4-042	Button	1	1	
41	1WF4-010	Set screw	2	2	SM15/64" 28/13.5
42	1WF4-011	Feed cam	1	1	
43	1WF4-012	Feed link	1	1	
44		Needle bearing	1	1	
45		Retainer	1	1	Washer 26 GB894.1-86
46	1WF2-055	Middle bushing assembly	1	1	
47	1WF2-051	Rear bushing for lower shaft	1	1	
48	1WF2-009	Screw	1	1	SM1/4" 40/4
49	1WF2-052	Screw	1	1	SM1/4" 40/5
50		Ball bearing	1	1	
51	1WF2-050	Bearing pressure ring	1	1	
52	1WF2-049	Set screw	3	3	SM9/64" 40/7
53	1WF4-044	Oil wick	1	1	
54	1WF4-043	Pin	1	1	

## 5. Automatic reverse feed and testing parts

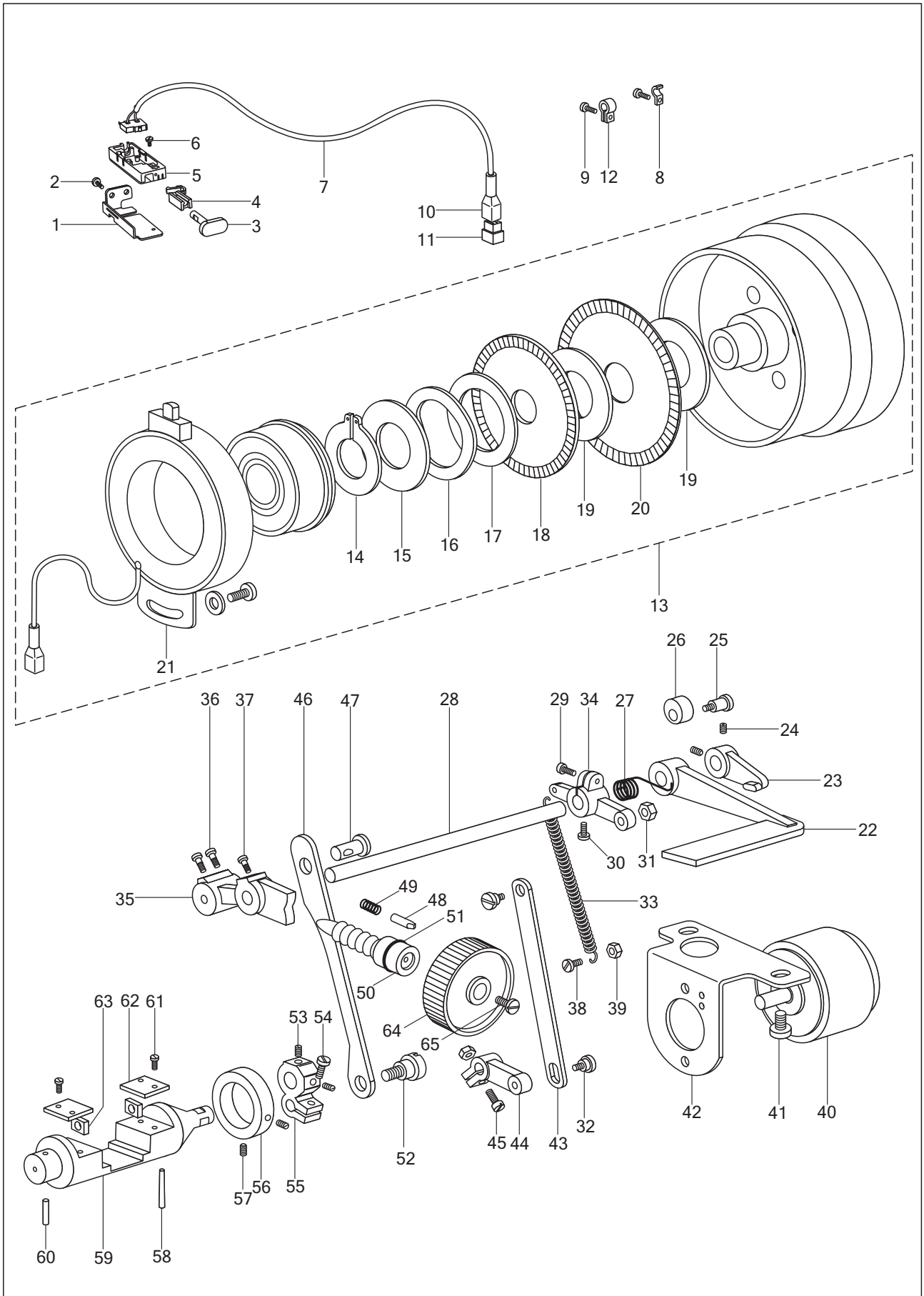

## 5. Automatic reverse feed and testing parts

No.	Part Number	Name	Qt.		Remark
			GC20606-D2	GC20606-1-D2	
1	62WF5-032	Position bracket	1	1	
2	21WF1-062	Screw	2	2	
3	2KT6-015	Switch	1	1	
4	2KT6-014	Connecting part	1	1	
5	2KT6-013	Switch bracket	1	1	
6		Screw	1	1	060300606
7	78WF2-005	Switch assembly	1	1	
8	84WF1-021	Clamp	3	3	
9	21WF3-026	Screw	3	3	
10	2KT8-002	Plug adapter	1	1	
11	2KT8-003	Cover	1	1	
12	84WF1-022	Clamp	1	1	
13	84WF1-023	Sensor assembly	1	1	8003-H
14		C-type retainer	1	1	GB894.1-86-30
15	84WF4-023A	Retainer	1	1	
16	84WF4-023B	Washer	1	1	
17	84WF4-023C	Spacer B	1	1	
18	84WF4-023D	Reflecting plate (upper)	1	1	
19	84WF4-023E	Spacer A	2	2	
20	84WF4-023F	Reflecting plate (lower)	1	1	
21	84WF4-023G	Probe unit assembly	1	1	
22	84WF4-009	Reverse feed lever	1	1	
23	84WF4-011	Crank	1	1	
24	1WF2-030	Screw	2	2	
25	84WF4-013	Position screw	1	1	
26	84WF4-012	Rubber band	1	1	
27	84WF4-014	Spring	1	1	
28	84WF1-010	Reverse feed lever shaft	1	1	
29	1WF4-027	Screw	1	1	
30	1WF4-021	Position screw	1	1	
31	6K2-040	Nut	2	2	
32	84WF4-008	Connecting screw	2	2	
33	84WF4-016	Spring	1	1	
34	84WF4-015	Crank	1	1	
35	84WF4-022	Stitch length adjusting bar	1	1	
36	1WF4-030	Screw	2	2	
37	1WF4-026	Position screw	1	1	
38	21WF4-055	Position screw	1	1	
39	6K3-017	Nut	1	1	
40	84WF4-004	Electromagnet	1	1	
41	84WF4-003	Screw	2	2	
42	84WF4-002	Electromagnet holder	1	1	
43	84WF4-007	Draw bar	1	1	
44	84WF4-006	Screw	1	1	
45	84WF4-005	Crank	1	1	



## 5. Automatic reverse feed and testing parts

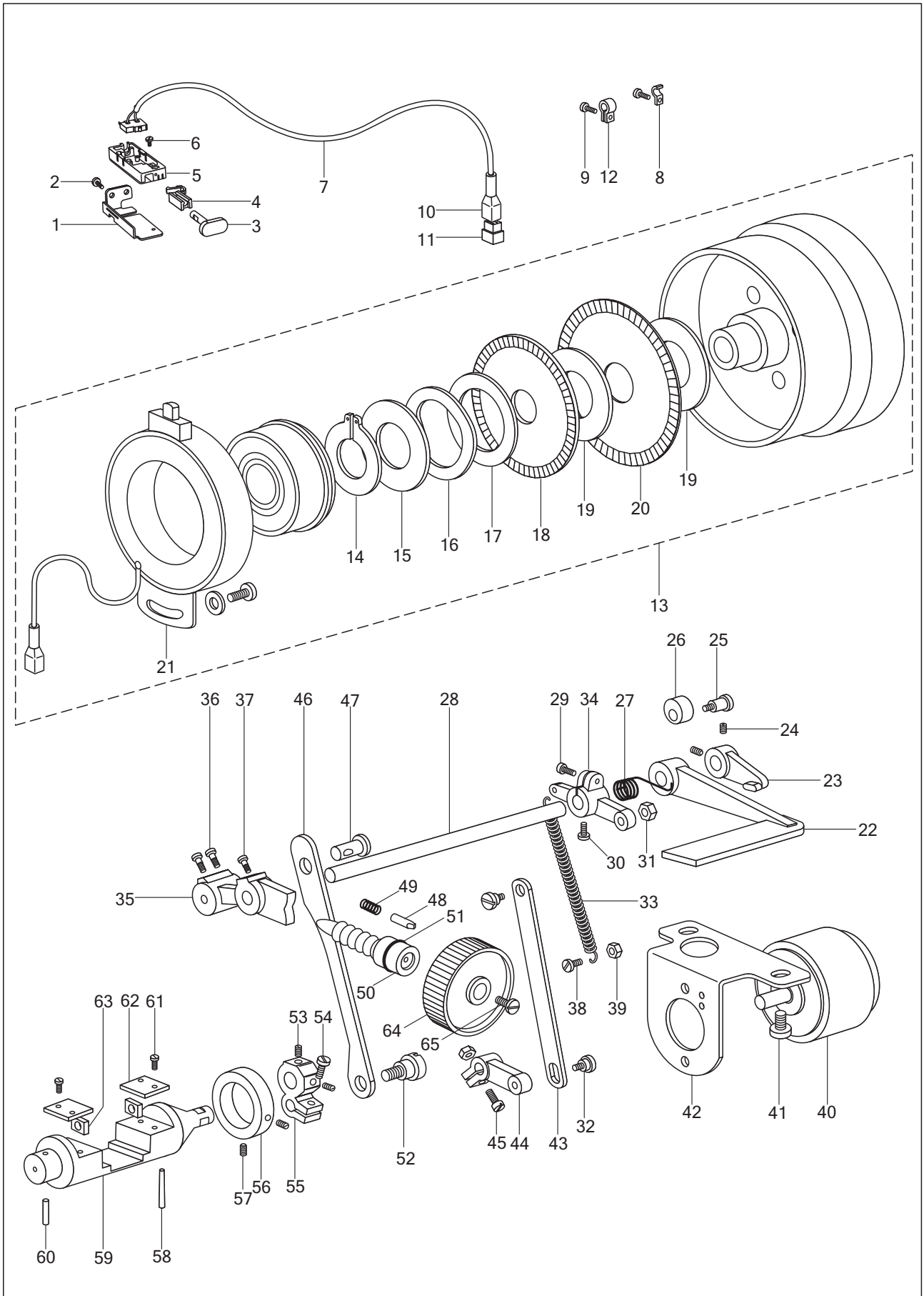

### 5. Automatic reverse feed and testing parts

No.	Part Number	Name	Qt.		Remark
			GC20606-D2	GC20606-1-D2	
46	84WF4-017	Stitch length link	1	1	
47	84WF4-020	Pin	1	1	
48	1WF4-024	Pin	1	1	
49	1WF5-006C3	Spring	1	1	
50	1WF4-023	Screw	1	1	
51		O-type seal ring	1	1	
52	84WF4-018	Eccentric pin	1	1	14 2 . 4 GB1235-86
53	6K2-043	Set screw	2	2	
54	84WF4-021	Set screw	1	1	
55	84WF4-019	Set screw	1	1	
56	1WF4-053	Crank	1	1	
57	1WF4-016	Collar	2	2	
58	1WF4-045	Set screw	1	1	
59	1WF4-057	Oil wick	1	1	
60	1WF4-039	Adjusting bracket	1	1	
61	1WF4-040	Oil wick	2	2	
62	1WF4-056	Slide block	2	2	
63	1WF1-011	Guide plate	4	4	
64	1WF4-022	Set screw	1	1	
65	1WF5-009	Set screw	1	1	

## 6. Thread releasing and auto-trimming parts

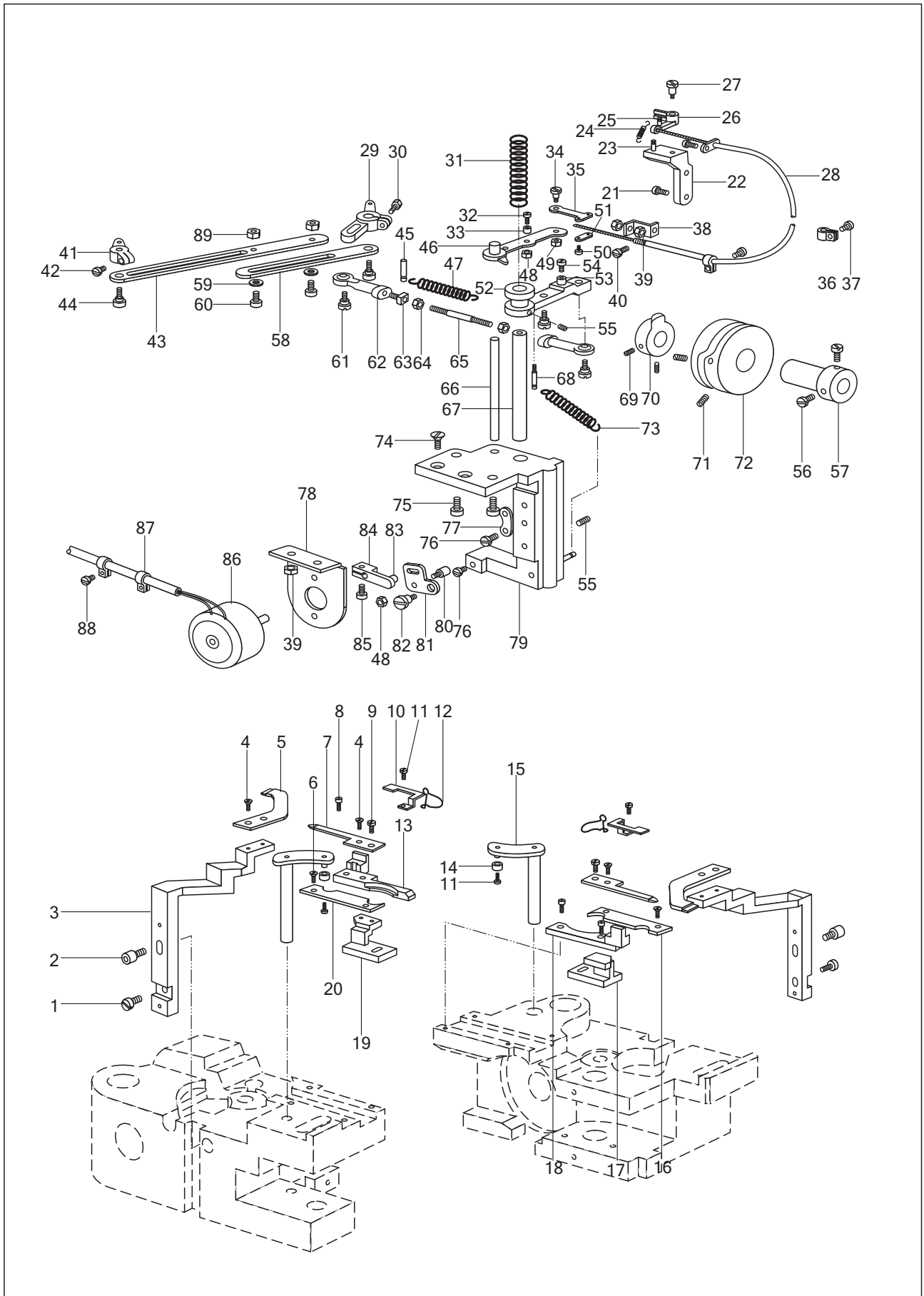

## 6. Thread releasing and auto-trimming parts

No.	Part Number	Name	Qt.		Remark
			GC20606-D2	GC20606-1-D2	
1	84WF3-014	Adjusting screw	2	1	
2	84WF3-015	Set screw	2	1	
3	84WF3-013	Set table	2	1	
4	84WF3-003	Screw	6	3	
5	84WF3-007	Fixed knife	2	1	Neue Nr. 84WF3-001
6	84WF3-002	Screw	4	2	
7	84WF3-009	Movable knife	2	1	Neue Nr. 84WF3-002
8	84WF3-002	Screw	6	3	
9	84WF3-004	Position screw	2	1	
10	84WF3-010	Spring	2	1	
11	84WF3-012	Screw	4	2	
12	84WF3-011	Spring	2	1	
13	83WF3-003	Guide bracket (left)	1	/	
14	84WF3-017	Roller	2	1	
15	84WF3-016	Trimming vibrating lever assembly	2	1	
16	84WF3-006	Pressure plate (right)	/	1	
17	84WF3-005	Set table (right)	/	1	
18	84WF3-008	Guide bracket (right)	/	1	
19	83WF3-001	Set table (left)	1	/	
20	83WF3-002	Pressure plate (left)	1	/	
21	1WF1-011	Screw	3	3	
22	84WF3-018	Connecting bracket	1	1	
23	84WF3-019	Pin	1	1	
24	84WF3-022	Spring	1	1	
25	84WF3-021	Pin	1	1	
26	84WF3-020	Crank	1	1	
27	84WF3-023	Screw	1	1	
28	84WF3-024	Thread releasing steel cable assembly	1	1	
29	84WF3-058	Crank (right)	1	1	
30	84WF3-059	Screw	1	1	
31	84WF3-041	Spring	1	1	
32	84WF3-030	Set screw	2	2	
33	84WF3-029	Slide block	1	1	
34	84WF3-032	Connecting screw	1	1	
35	84WF3-031	Connecting plate	1	1	
36	84WF1-021	Clamp	2	2	
37	1WF1-011	Screw	2	2	
38	84WF3-025	Set plate	1	1	
39		Nut	4	4	GB41-86-M5
40	1WF1-005	Screw	1	1	
41	83WF3-004	Crank (left)	1	/	
42	83WF3-005	Screw	1	/	
43	83WF3-006	Draw bar (long)	1	/	
44	83WF3-009	Set screw	2	/	
45	22T7-008	Pin	2	2	

## 6. Thread releasing and auto-trimming parts

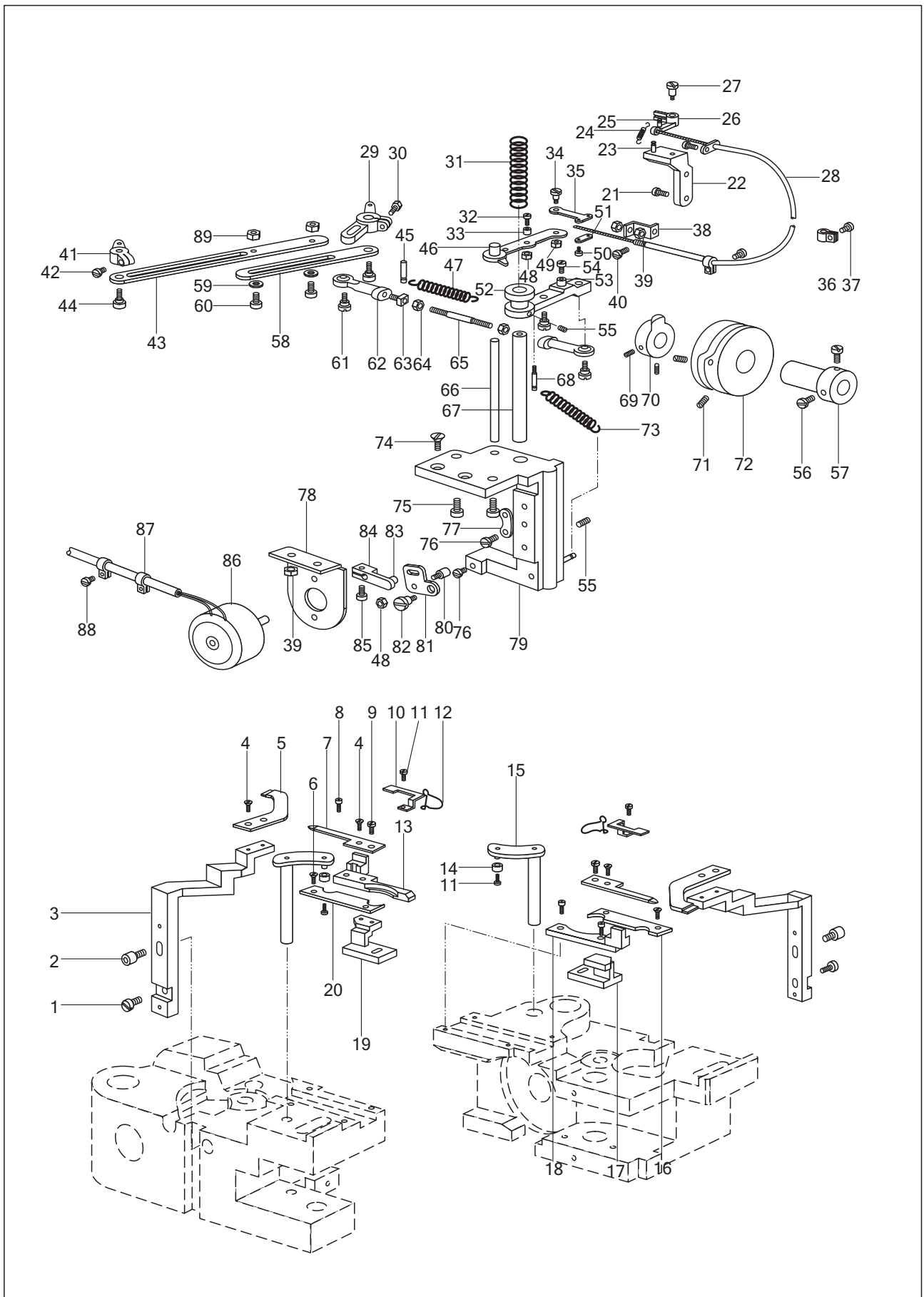

## 6. Thread releasing and auto-trimming parts

No.	Part Number	Name	Qt.		Remark
			GC20606-D2	GC20606-1-D2	
46	84WF3-026	Thread releasing vibrating lever assembly	1	1	
47	84WF3-044	Spring	1	1	
48	6K3-017	Nut	2	2	
49	84WF3-033	Connecting nut	1	1	
50	84WF3-035	Screw	2	2	
51	84WF3-034	Pressure plate	1	1	
52	84WF3-042A	Crank	1	1	
53	84WF3-042B	Slide block	1	1	
54	84WF3-042C	Set screw	1	1	
55	84WF3-043	Screw	3	3	
56	1WF2-038	Screw	2	2	
57	84WF3-061	Position bushing	1	1	
58	83WF3-007	Draw bar (short)	1	/	
59		Washer	2	/	GB97. 1-85-5
60	83WF3-008	Connecting screw	2	/	
61	84WF3-055	Connecting screw	2	2	
62	84WF3-054	Adapter assembly	2	2	
63	84WF3-056	Adapter bracket	1	1	
64		Nut	2	2	
65	84WF3-057	Connecting screw	1	1	
66	84WF3-036	Guide shaft	1	1	
67	84WF3-040	Crank shaft	1	1	
68	84WF3-027	Pin	1	1	
69	84WF3-038	Position screw	2	2	
70	84WF3-037	Thread realeasing cam	1	1	
71	21WF1-022	Screw	2	2	
72	84WF3-060	Trimming cam	1	1	
73	84WF3-028	Spring	1	1	
74	59WF2-003 I	Screw	2	2	
75	21WF2-043	Set screw	2	2	
76	21WF4-047	Screw	3	3	
77	84WF3-048	Position plate	1	1	
78	84WF3-050	Set plate	1	1	
79	84WF3-039	Set plate	1	1	
80	84WF3-047	Screw	3	2	
81	84WF3-045	Electromagnet vibrating lever	1	1	
82	84WF3-046	Screw	1	1	
83	84WF3-053	Trimming electromagnet vibrating lever	1	1	
84	84WF3-052	Crank	1	1	
85	21WF4-055	Screw	1	1	
86	84WF3-049	Electromagnet	1	1	
87	1WF6-036	Clamp	2	2	
88	1WF1-026	Screw	2	2	
89	21WF1-051	Nut	2	2	

## 7. Knee control presser foot lift parts

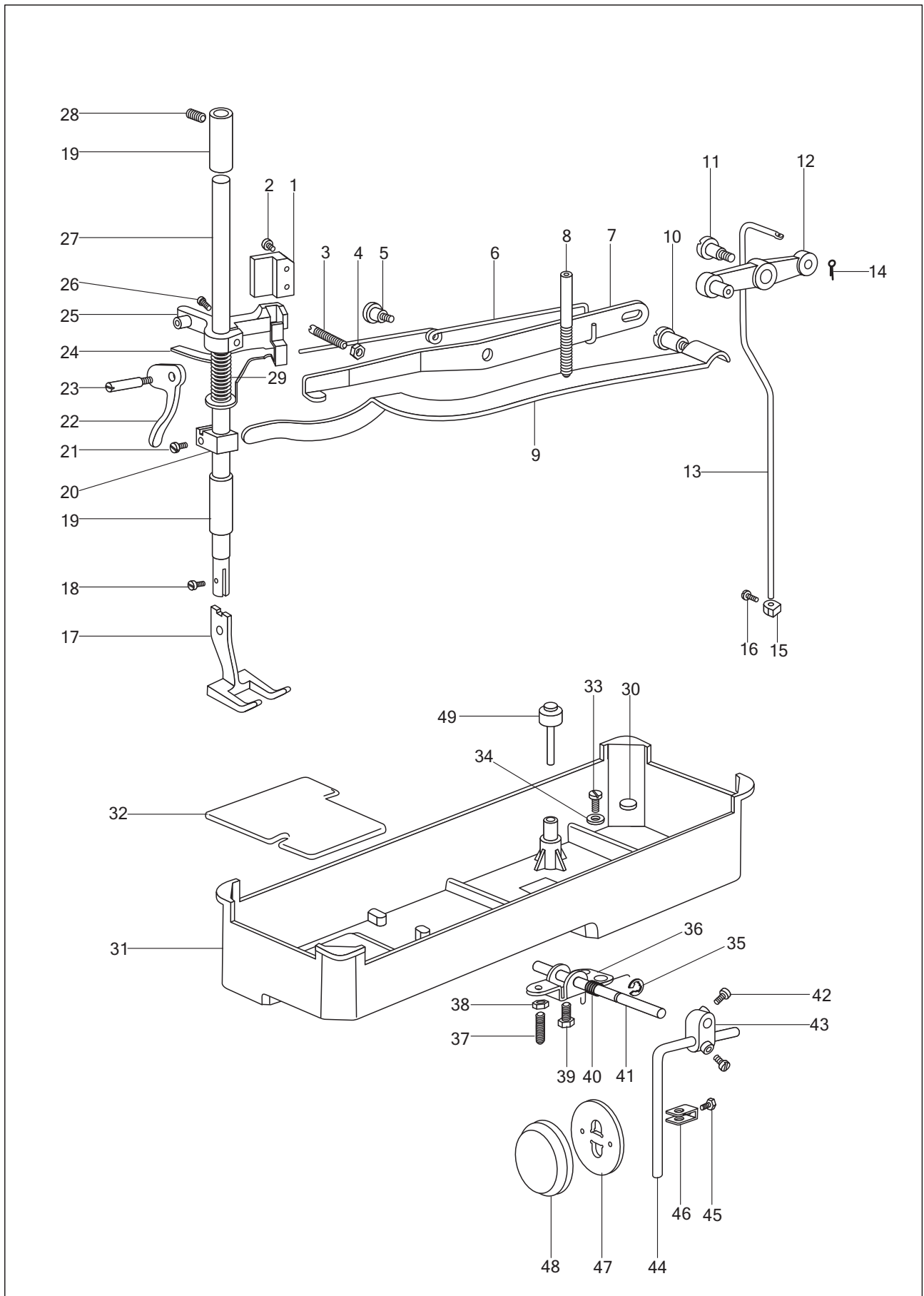



## 7. Knee control presser foot lift parts

No.	Part Number	Name	Qt.		Remark
			GC20606-D2	GC20606-1-D2	
1	1WF5-040	Slide groove	1	1	
2	1WF5-039	Screw	2	2	SM1/64" 40/12
3	1WF3-011	Screw	1	1	SM1/4" 24/16.5
4	1WF3-010	Nut	1	1	
5	1WF3-013	Screw	1	1	
6	1WF3-014	Spring	1	1	
7	1WF3-012	Knee control lift bar	1	1	
8	1WF3-015	Screw	1	1	
9	1WF3-016	Spring	1	1	
10	1WF3-018	Screw	1	1	
11	1WF3-017	Screw	1	1	
12	1WF3-019	Knee control crank assembly	1	1	
13	1WF3-021	Prop rod	1	1	
14	1WF3-020	Split pin	1	1	
15	1WF3-024	Position bushing	1	1	
16	1WF3-025	Screw	1	1	
17	1WF3-001	Presser foot	1	/	
	9WF3-001	Presser foot	/	1	
18	1WF3-002	Set screw	1	1	
19	1WF3-004	Bushing	2	2	
20	1WF3-005	Spring bracket	1	1	
21	1WF2-006	Screw	1	1	SM9/64" 40/8.5
22	1WF3-023	Feed dog lift lever	1	1	
23	1WF3-022	Screw	1	1	
24	1WF3-007	Thread releasing plate	1	1	
25	1WF3-008	Guide bracket	1	1	
26	1WF3-009	Screw	1	1	SM11/64" 40/15
27	1WF3-003	Presser bar	1	1	
28	1WF3-023	Screw	2	2	SM1/4" 24 23
29	1WF3-006	Spring	1	1	
30	22F9-012	Magnet	1	1	
31	58F0-001A1	Oil reservoir	1	1	
32	58F0-001	Cushion	1	1	
33	22T9-001A2	Screw	1	1	SM5/16" 25/10
34	22T9-001A3	Washer	1	1	
35		Retainer	1	1	φ9 GB896-86
36	1WF3-028	Position bracket	1	1	
37	22T9-001A9	Screw	2	2	SM15/64" 28/28
38	22T9-001A10	Adjusting nut	2	2	
39	22T9-007C2	Screw	1	1	SM15/64 28/15
40	22T9-001A7	Spring	1	1	
41	1WF3-027	Hinge shaft	1	1	
42	22T9-003B4	Screw	2	2	SM5/16 18/13
43	22T9-003B3	Adapter	1	1	
44	22T9-003B2	Bent bar	1	1	
45	22T9-003B7	Screw	1	1	SM15/64"28/18
46	22T9-003B6	Bell bracket	1	1	
47	22T9-003B5	Bell	1	1	
48	22T9-003B8	Pat	1	1	
49	1WF3-026	Prop bar	1	1	

## 8. Lubrication parts

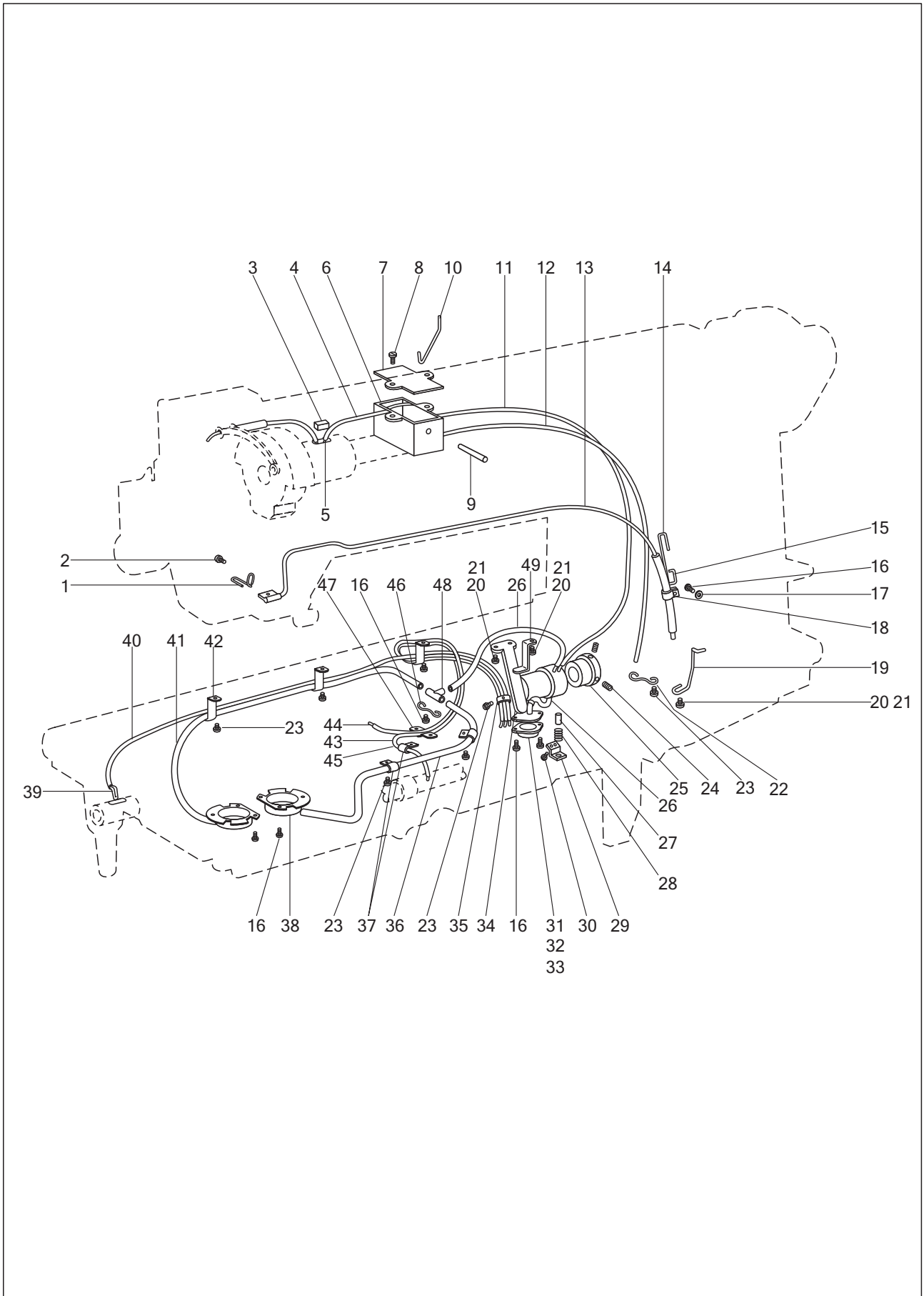

## 8. Lubrication parts

No.	Part Number	Name	Qt.		Remark
			GC20606-D2	GC20606-1-D2	
1	1WF6-001	Spring	1	1	
2	1WF6-034	Screw	1	1	SM3/16" 28/12
3	1WF6-003	Oil felt	1	1	Felt
4	1WF6-005A	Oil pipe	1	1	3D 0.5 60
5	1WF6-004	Oil wick	1	1	Cotton thread
6	1WF6-007	Oil pot	1	1	Organic glass
7	1WF6-008	Oil top cover	1	1	Oil resistant rubber
8		Screw	2	2	M4 16 GB69-85
9	1WF6-009	Pin	1	1	
10	1WF6-006	Spring	1	1	
11	1WF6-010	Oil pipe	1	1	3D 1 400
12	1WF6-011	Oil pipe	1	1	5D 1 400
13	1WF6-002	Oil wick	1	1	φ2.5 550 Cotton thread
14	1WF6-013	Position clamp	1	1	
15	1WF6-012	Oil pipe	1	1	3D 0.5 150
16	1WF1-024	Screw	10	10	SM9/64" 40/9
17		Washer	1	1	Washer 4 GB7246-87
18	1WF6-042	Oil pipe clamp	1	1	
19	1WF6-014	Spring	1	1	
20	1WF1-011	Screw	4	4	SM11/64" 4 0/9
21	22T1-007	Washer	4	4	
22	1WF6-021	Clamp	1	1	
23	1WF1-026	Screw	8	8	SM9/64" 4 0/4.5
24	1WF2-053	Screw	2	2	SM11/64" 40/10
25	1WF2-054	Bushing	1	1	
26	1WF6-027	Oil pipe	2	2	3D 1 90
27	1WF6-025	Plunger	1	1	
28	1WF6-024	Spring	1	1	
29	1WF6-023	Retaining plate	1	1	
30	1WF6-026	Screw	1	1	SM1/8" 44/4.5
31	1WF6-018	Oil filter	1	1	
32	1WF6-019	Washer	1	1	
33	1WF6-020	Filter screen	1	1	H62 Bronze
34	1WF6-017	Set plate	1	1	
35	1WF6-028	Oil pipe clamp	1	1	
36	1WF6-035	Oil pipe	1	1	
37	1WF6-036	Clamp	3	3	
38	1WF6-038	Oil tray assembly	2	1	
39	1WF6-041	Oil wick	1	1	φ2.5 430 Cotton thread
40	1WF6-040	Oil pipe	1	1	3D 0.5 410
41	1WF6-039	Oil pipe	1	/	3D 1 445
42	1WF6-034	Clamp	3	3	
43	1WF6-032	Oil pipe	2	2	3D 0.5 220
44	1WF6-037	Oil wick	1	1	φ2.5 300
45	1WF6-033	Oil wick	1	1	φ2.5 240
46	1WF6-030	Set clamp	1	/	
47	1WF6-031	Oil pipe clamp	1	1	
48	1WF6-029	3-nozzle oil mouth assembly	1	/	
49	1WF6-015	Set clamp	1	1	

# 9. Accessory

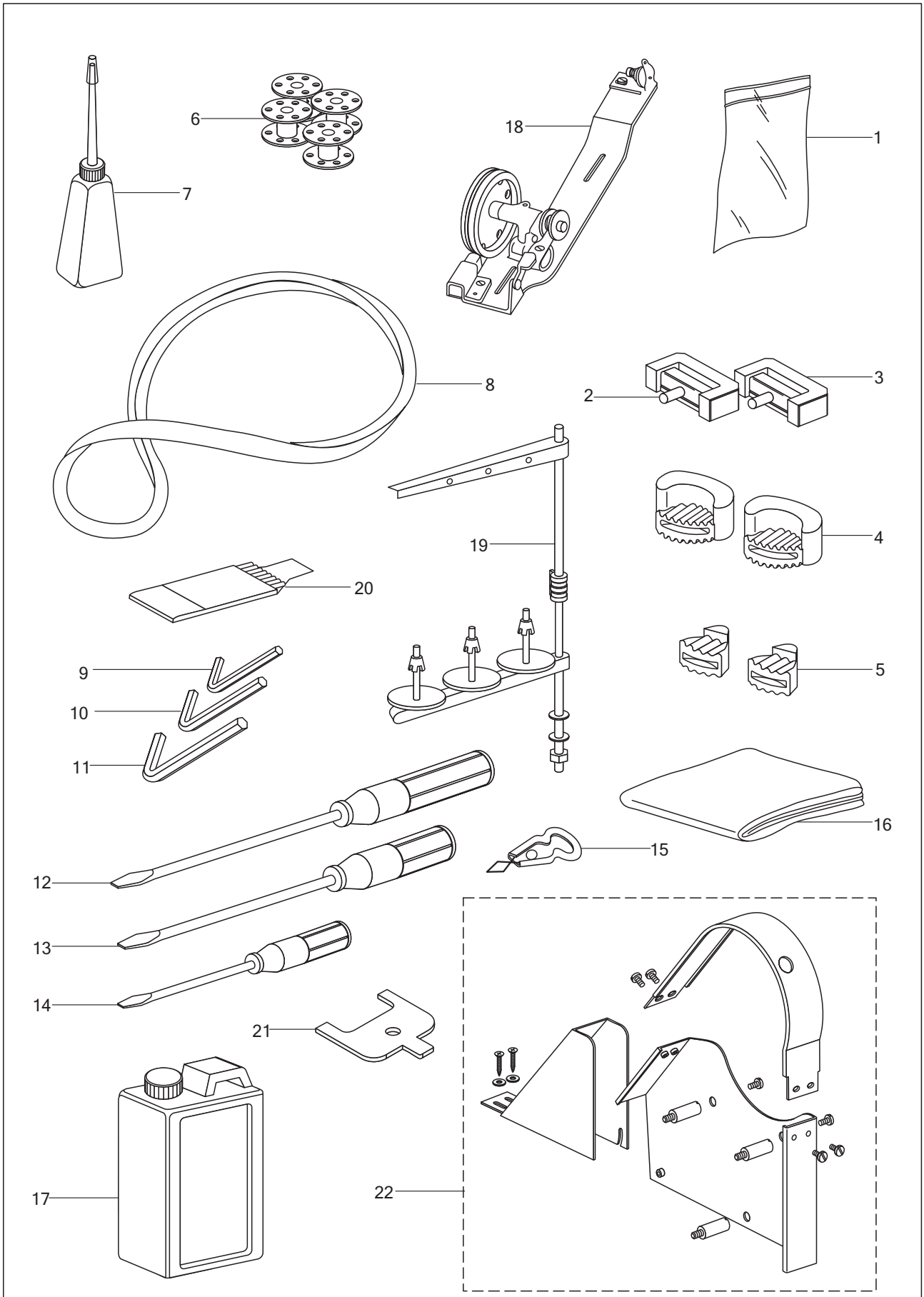

## 9. Accessory

No.	Part Number	Name	Qt.		Remark
			GC20606-D2	GC20606-1-D2	
1	33TF-010	Accessory bag	1	1	
2	22T9-007F1	Hinge pin	2	2	
3	22T9-007F2	Hinge pin socket	2	2	
4	22T9-009	Cushion	2	2	
5	22T9-010	Cushion	2	2	
6	1WF2-065	Bobbin	4	4	
7	33TF-011	Oil pot	1	1	
8	33TF-016	V-belt	1	1	V-type 1050
9	13F-009	Spanner	1	1	S=2mm
10	1F-010	Spanner	1	1	S=2.5MM
11	1F-011	Spanner	1	1	S=3MM
12	33TF-012	Screwdriver	1	1	
13	33TF-013	Screwdriver	1	1	
14	33TF-014	Screwdriver	1	1	
15	58T0-007C	Thread tweezer assembly	1	1	
16	22T9-018	Arm cover	1	1	
17	1F-012	Oil tank	1	1	
18	S14420020	Bobbin winder	1	1	
19	1F-014	Thread spool stand	1	/	
	33TF-019	Thread spool stand	/	1	
20	78WF7-001	Probe unit adjusting plate	1	1	
21		Needle	1	1	DP 1 7 23 <sup>#</sup>
22	1WF7-012	Safety guard assembly	1	1	

# Content

## Operation Instruction

1. Brief introduction.....	1
2. Main specifications.....	1
3. Installation and preparation.....	1-4
4. Operation.....	4-8
5. Machine adjustment.....	5-13

## Parts Manual

1. Arm parts.....	14-17
2. Upper shaft and presser foot parts.....	18-19
3. Needle bar and lower feed parts.....	20-23
4. Lower shaft and thread looping parts.....	24-25
5. Automatic reverse feed and testing parts.....	26-29
6. Thread releasing and auto-trimming parts.....	30-33
7. Knee control presser foot lift parts.....	34-35
8. Lubrication parts.....	36-37
9. Accessory.....	38-39