



TYPICAL

GC2605

Cylinder Bed Compound Feed Binding Machine

Contents

1. Brief introduction	1
2. Main specifications	1
3. Installation and preparation	1
3.1 Installation	1
3.1.1 Location of the machine	1
3.1.2 Installing drip pan	1
3.1.3 Installing machine head	1
3.1.4 Mounting rock shaft bracket of knee lifter	1
3.1.5 Installing motor	2
3.1.6 Connecting the clutch lever to the pedal	2
3.1.7 Installing the bobbin winder	2
3.1.8 Installing the thread unwinder	2
3.2 Preparation	3
3.2.1 Cleaning the machine	3
3.2.2 Examination	3
3.2.3 Lubrication.....	3
3.2.4 Trial run	4
4. Operation	4
4.1 Selection of the thread	4
4.2 Coordination between needle thread and sewing material	5
4.3 Installing the needle	5
4.4 Winding the bobbin thread	5
4.4.1 Winding method	5
4.4.2 Winding adjustment	6
4.5 Threading the needle thread and drawing the bobbin thread	6
4.6 Setting the bobbin	7
4.7 Installing the bobbin case	7
4.8 Setting stitch length and reverse sewing	7
5. Adjusting the thread tension	7
5.1 Adjusting the thread take-up spring	8
5.1.1 Adjusting the thread take-up spring tension	8
5.1.2 Adjusting the sewing range of thread take-up spring	8
5.2 Adjusting the thread guide	9
5.3 Adjusting the tension of needle thread and bobbin thread	9
6. Adjustment	10
6.1 Timing between needle and rotating hook motion	10
6.1.1 Adjusting the needle bar position	10
6.1.2 Adjusting rotating hook point timing with needle	10
6.1.3 Removing and installing the rotating hook.....	10
6.1.4 Adjusting the clearance between rotating hook and bobbin case holder position bracket	10

Contents

6.2 Adjusting the feed dog.....	11
6.3 Adjusting the tension releasing mechanism	11
6.4 Adjusting the pressure of presser foot	11
6.5 Timing feed adjustment	11
6.6 Presser foot alternate lift amount adjustment.....	12
6.7 Presser foot total lift amount adjustment.....	12
6.8 Presser feet gauge adjustment	13
7. Periodical cleaning	13
8. Troube And Remedy	14

Parts manual Contents

1. Arm and bed	15~18
2. Needle bar and thread take-up	19~20
3. Arm shaft and vertical shaft	21~22
4. Rotating hook and its oscillating shaft	23~24
5. Stitch length regulating	25~26
6. Lower feed	27~28
7. Presser bar and drawing bar	29~30
8. Top feed.....	31~32
9. Lubrication	33~34
10. Knee lifter	35~36
11. Accessories	37~38

1. Brief introduction

UC 2685 cylinder

Specifications

Weight, Dimensions, etc.

Contents

2. After it is properly

operation of the machine
machine must be focused on the road for the
smooth motion and reduce the
power consumption.

3. Mounting the machine

When mounting the machine on a truck, the
mounting holes on the base will be made on
the hole of the truck and should be plugged
with the rubber stopper and will be fastened. The base
will be inserted into the position hole
(Fig. 1) adjusting the base so that it can
move freely. Finally the top cover will be fastened (see
Fig. 2).

3.1.1 Mounting the motor

When mounting the motor, the motor will be made to engage
with the gear of the truck. The motor will be inserted in the
position hole of the truck and will be fastened with the
nut and washer. The motor will be
fastened and fixed.

3.1.4 Mounting the rock shaft bracket of liner after

(see figure on page 33)
The rock shaft plate is inserted into the hole
of the truck and will be fastened with the
nut and washer. The rock shaft bracket will
be inserted into the hole of the truck and will
be fastened with the nut and washer.



1. Brief introduction

Model GC 2605 cylinder bed compound feed binding sewing machine is constructed with single straight needle, link thread take-up with needle bearing, precise spiral bevel gear transmission, big rotating hook with double capacity and forward or reverse sewing. It has the advantages of stable motion, small moment of force, low noise, beautiful plat stitches in appearance. It is widely used in the factories of garments, leather goods, suits & case, and others.

2. Main Specifications

- | | |
|---------------------------|---|
| 1) Max. sewing speed: | 2,000spm |
| 2) Max. stitch length: | 6mm |
| 3) Presser foot lift: | 6.5mm(13 mm by knee) |
| 4) Max. Sewing thickness: | 8mm |
| 5) Needle: | Model DP×17 Nm110~180 |
| 6) Rotating hook: | big rotating hook with double thread capacity |
| 7) Motor: | 370w (special for sewing machine) |

3. Installation and preparation

3.1 Installaion

3.1.1 Location or the machine

The machine must be located on rigid and flat floor for ensuring its smooth motion and reducing its vibration. Furthermore, a rubbermat should be inserted into between the machine stand and the floor for further. reducing the running noise.

3.1.2 Mounting the base of the machine head

First of all the knee lifter pushing rod screw will be set into the table and Nut 3 will be fastened (see Page 32).

Then the four screw holes of the base will be made to align the four holes of the table and should be plunged through four bolts and will be fastened. The knee liner pushing rod B should be inserted into the position hole of the base (Fig. 1).adjusting the base to make rod B insert it freely. Finally the four bolts will be fastened again.

3.1.3 Mounting the machine head (Fig.2)

At first, half of the hinge should be made to engage with the base of the head, then put the head lightly on the base of the head and movfing slightly. The three screw holes of the hinge of the head shall be made to align with the three holes of the hinge and the three screws will be fastened and fixed.

3.1.4 Mounting the rock shaft bracket of knee lifter (Fig. 3,also see figure on page 32)

1) Adjust rock shaft plate 18 according to the body of the operator, ensuring easy operation, light force and proper swing angle.

2)Adjust the position of the knee lifter assembly according to Fig.3, then fasten rock shaft bracket 7 with wood screws 6.

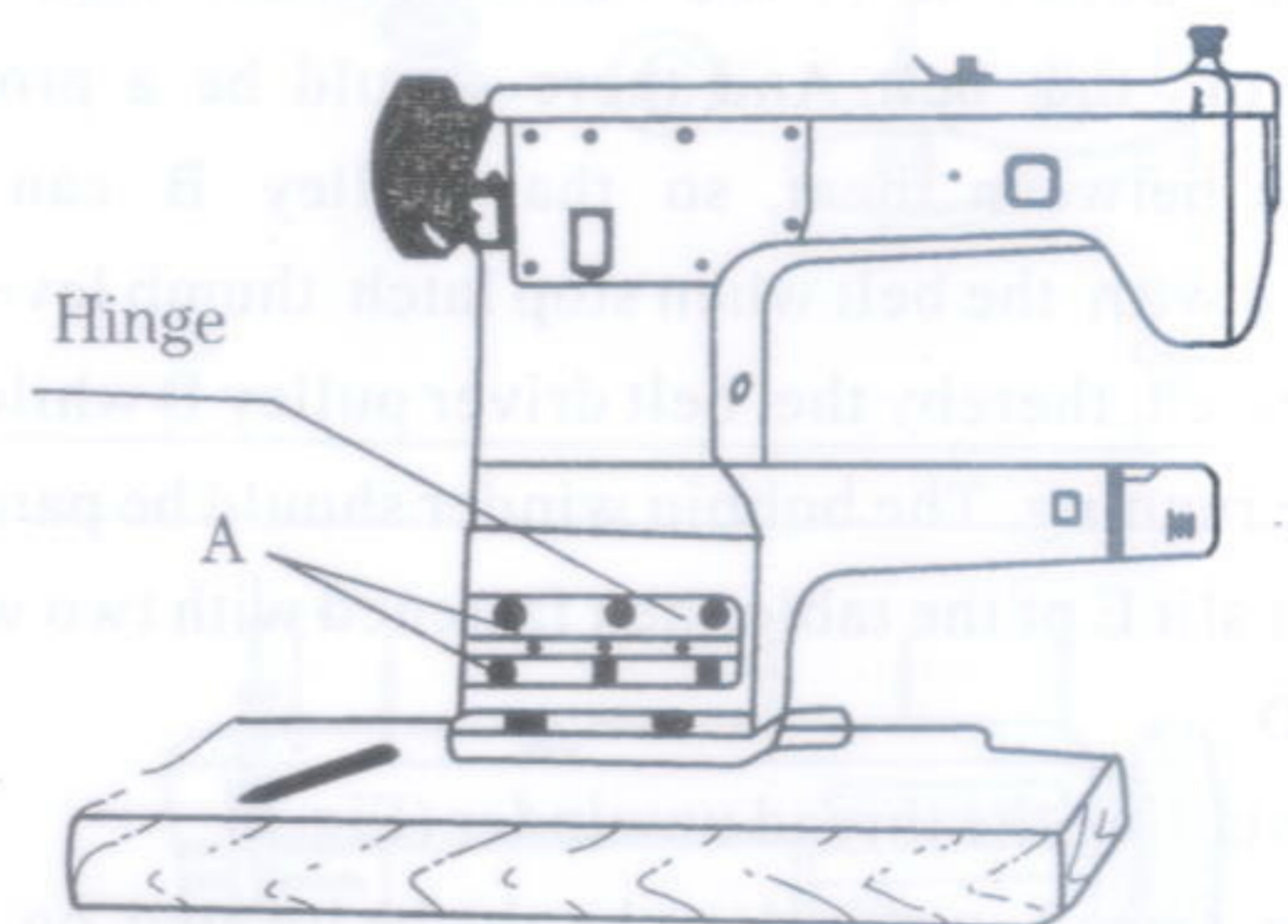
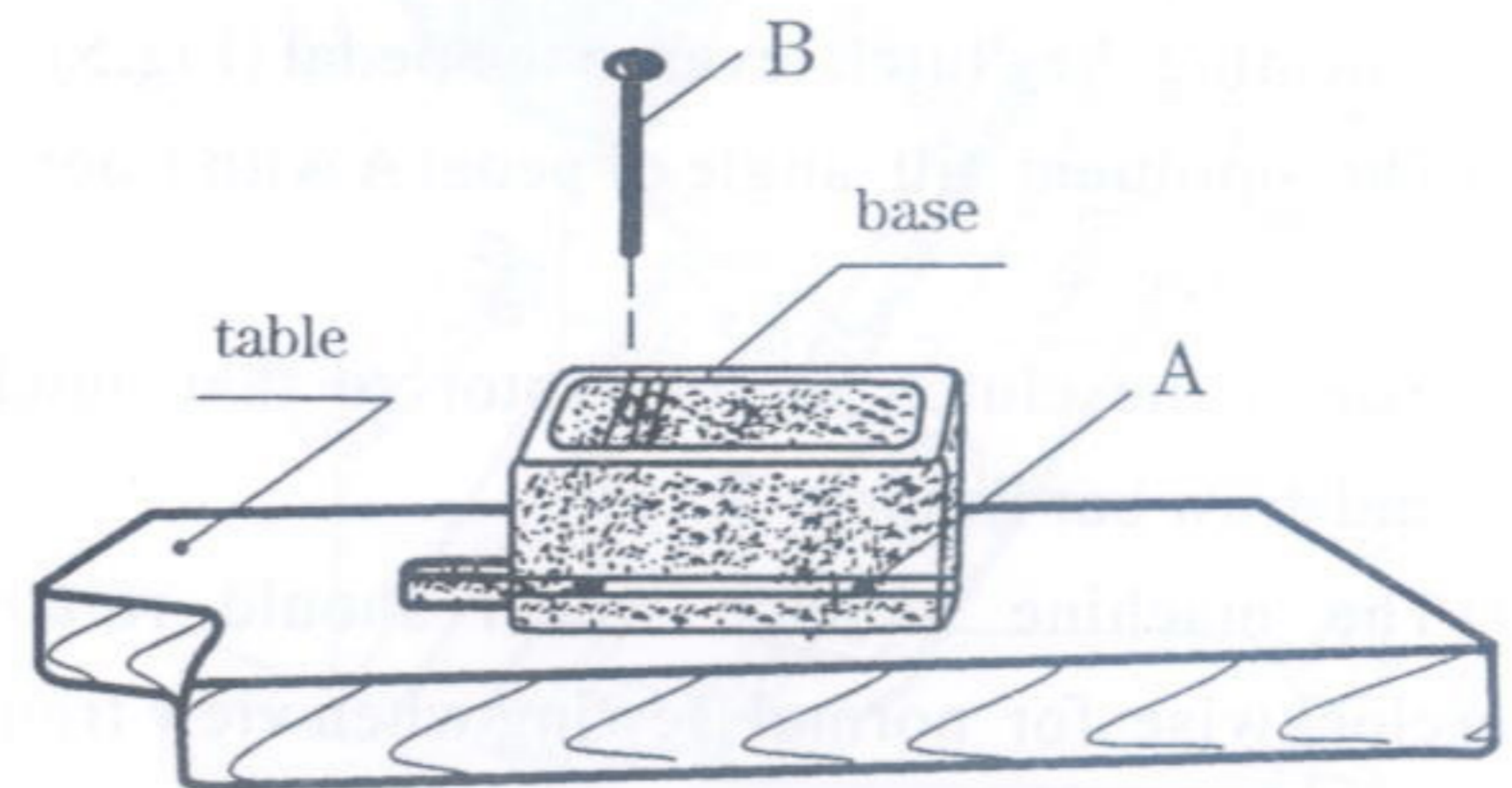

Fig.2

3.1.5 Installing the motor (Fig.4)

Align machine balance wheel belt groove A with motor pulley belt groove B by moving motor C leftward or rightward. Be sure the belt is not touch with the table.

3.1.6 Connecting the clutch lever to the pedal (Fig.5)

1) The optimum tilt angle of pedal A with floor is approx. 15 degree.

2) Adjust the clutch of the motor so that clutch lever C and draw bar B run in line.

3) The machine balance wheel should rotate counterclockwise for normal sewing when view from opposite side of the balance wheel. The motor rotates in the same direction. The rotation can be reversed by reversing (turn over 180 deg.) the plug of the motor.

4) Adjust the tension of V-belt F by moving the motor vertically. The proper tension of V-belt is a slack of 10-12mm when the belt is depressed (at the belt span) by forefinger.

3.1.7 Installing the bobbin winder (Fig.6)

Align pulley B of the bobbin winder with the outside of the belt. And there should be a proper clearness between them, so that pulley B can be contacted with the belt when stop latch thumb lever A is depressed, thereby the belt driver pulley B while the machine running. The bobbin winder should be parallel with belt slit E of the table, then fastened with two wood screws D.

3.1.8 Installing the thread unwinder (Fig.7)

The thread unwinder should be located on the right back side of the table. Threading should be smooth when sewing and the spool rest may not obstruct when the machine head is turned backward, then tighten wood screw C.

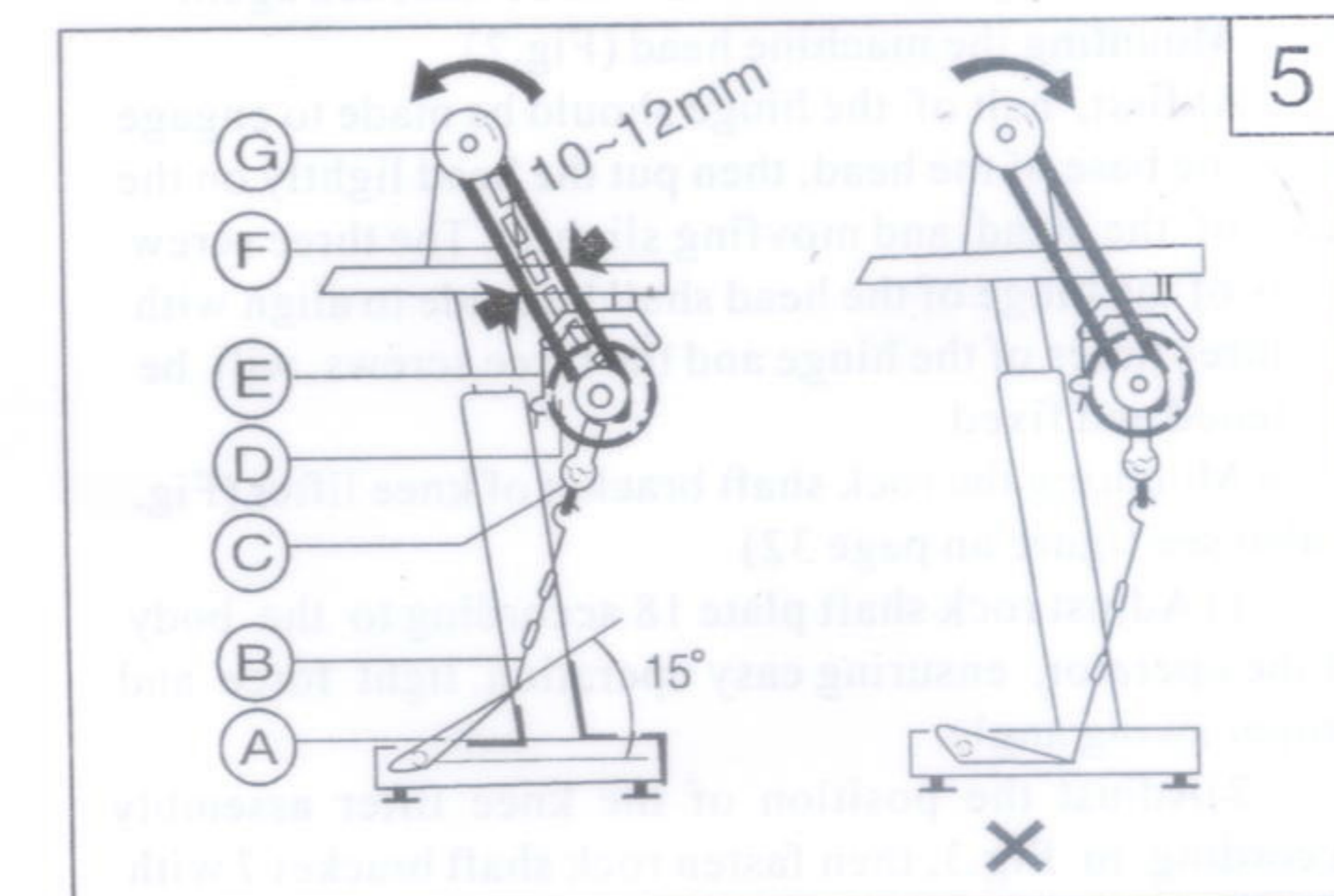
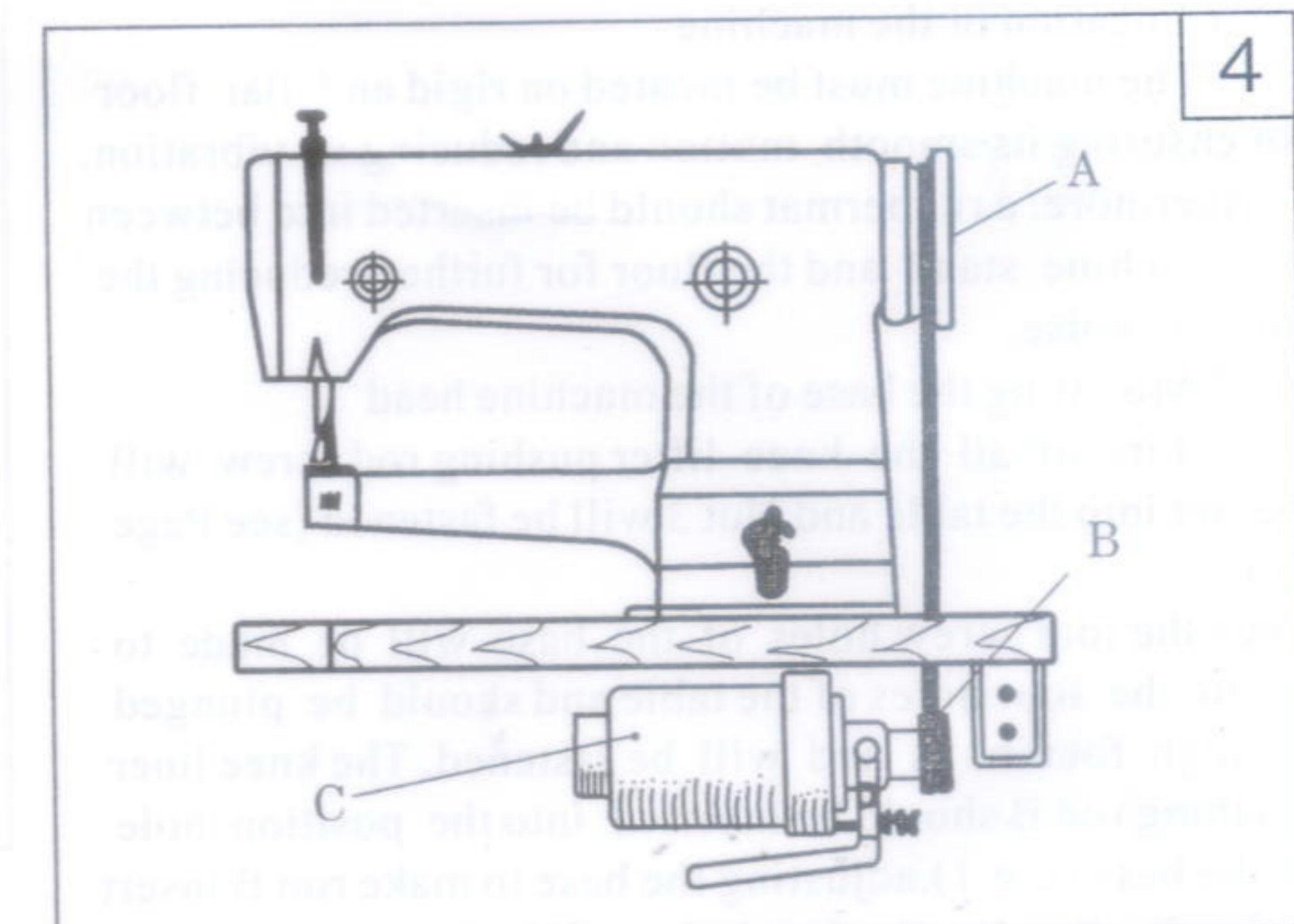
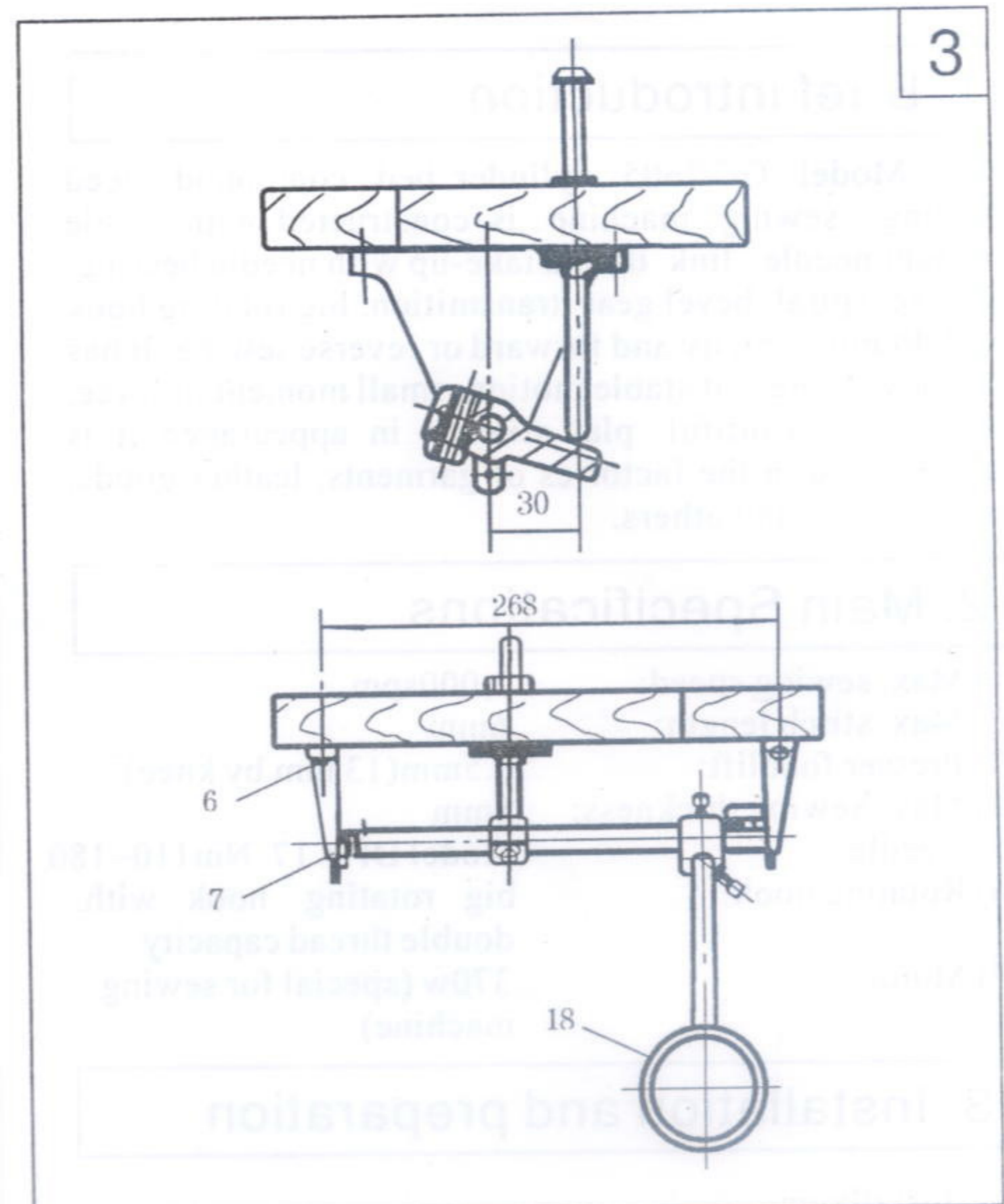

3.2 Preparation

3.2.1 Cleaning the machine

Before the head is packed, all the parts of the machine are coated with preventive grease, which may be hardened and contaminated by dust during long storage and shipment. This grease must be removed by clean cloth with gasoline.

3.2.2 Examination

The parts of the machine may be loose and deformed after long distance transportation with jolt though every machine is confirmed by strict inspection and test before delivery. A thorough examination must be performed after cleaning the machine. Turn the balance wheel to check if there is running obstruction, parts collision, uneven resistance or abnormal noise. If any of these exist, adjustment must be made accordingly before running.

3.2.3 Lubrication

Before running, the machine must be oiled at the places by arrow as shown in Fig.8. If the machine continues in operation, it should be oiled not less than twice per shift.

In lubrication, HA-8 sewing machine oil or HJ-7 machine oil must be used.

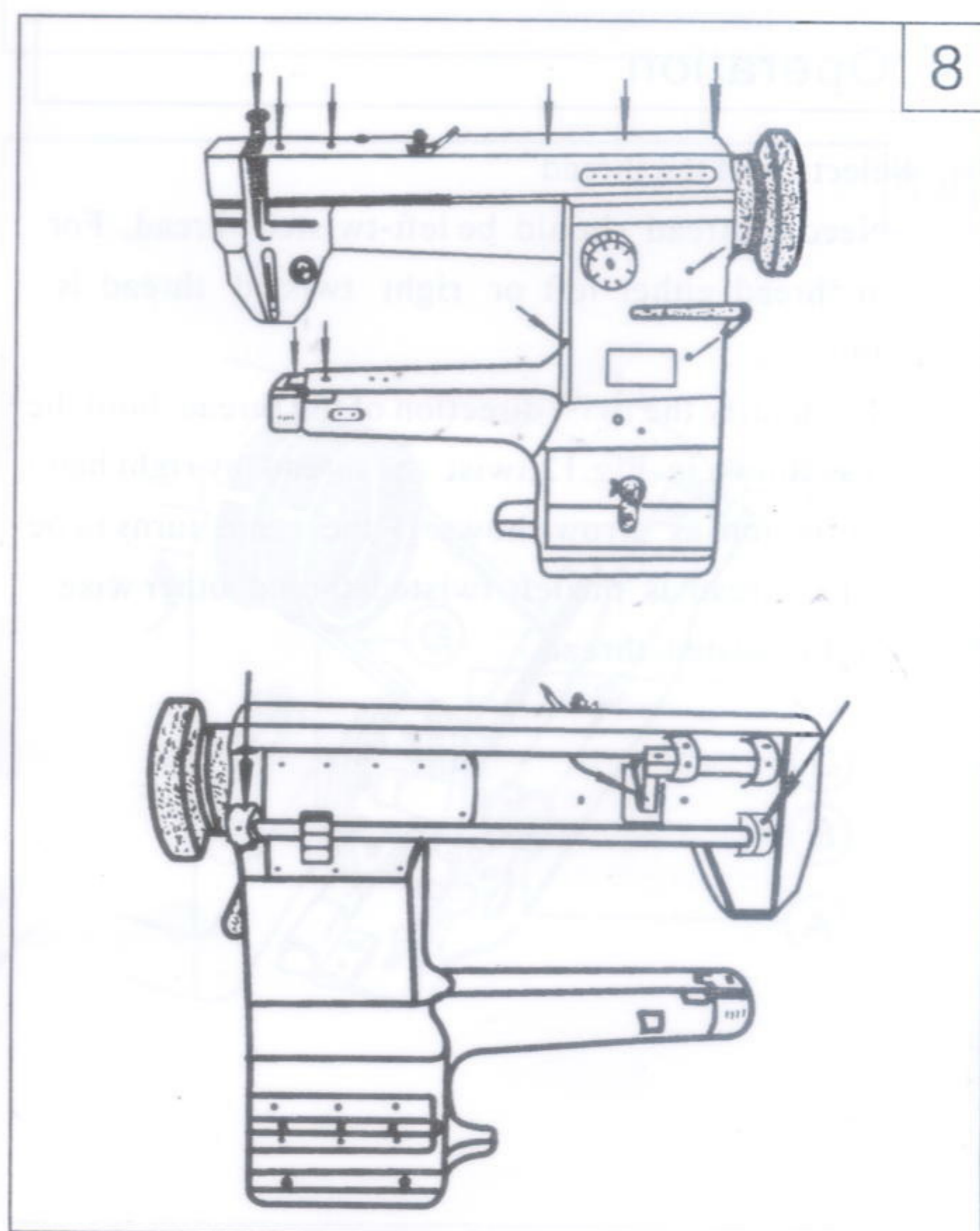
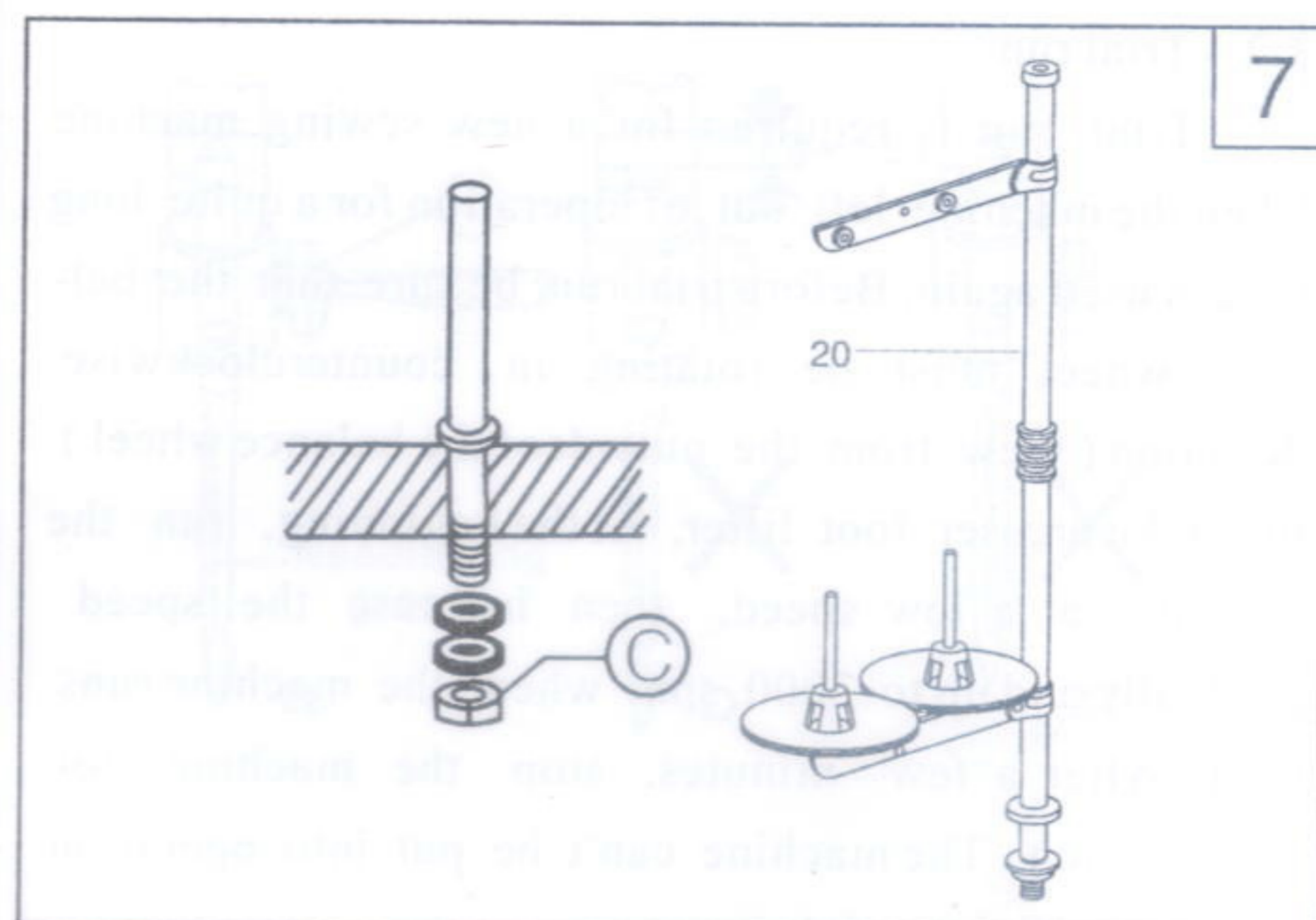
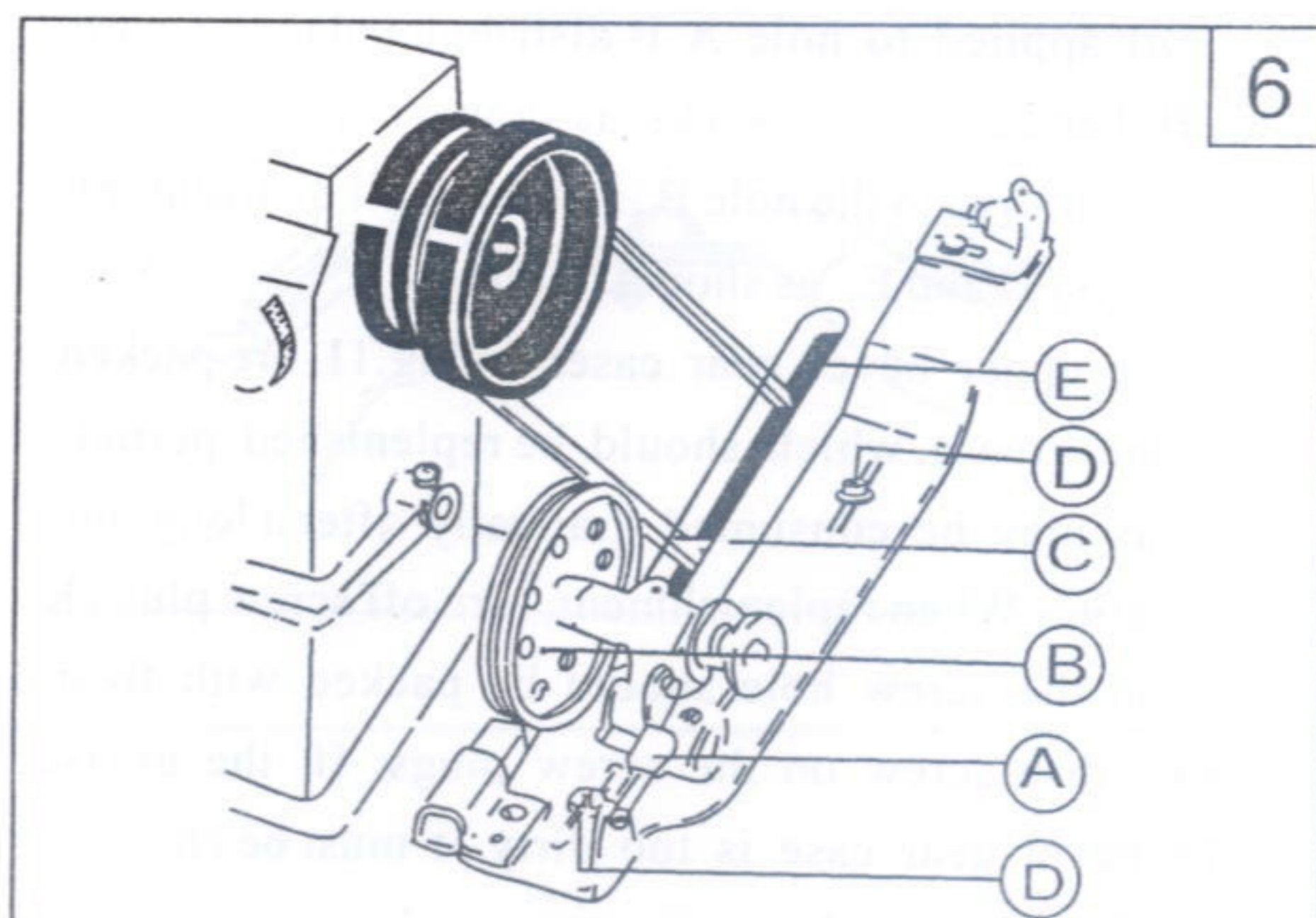

Oil applied to hole A is distributed to the parts F, G, H, I and J through wicks, as shown in Fig.9.

Oil applied to the hole B is through oil distributor to the parts C, D and E, as shown in Fig.10.

The upper bevel gear cases in Fig.11, are packed with fine grease, which should be replenished periodically as may be consumed gradually after a long time of operation. When replenishment, turn off screw plugs K first and the screw hole should be packed with fresh grease, thru screw on the screw plugs. If the grease in the bevel gear case is too dirty, it must be changed thoroughly.

3.2.4 Trial run

Trial run is required for a new sewing machine when the machine left out of operation for a quite long time is used again. Before trial run, be sure that the balance wheel must be rotating in counterclockwise direction (view from the outside of the balance wheel) to lift the presser foot lifter. At the beginning, run the machine at a low speed, then increase the speed gradually and up to 2000 spm when the machine runs well. After a few minutes, stop the machine for examination. The machine can't be put into operation without sufficient trial run.

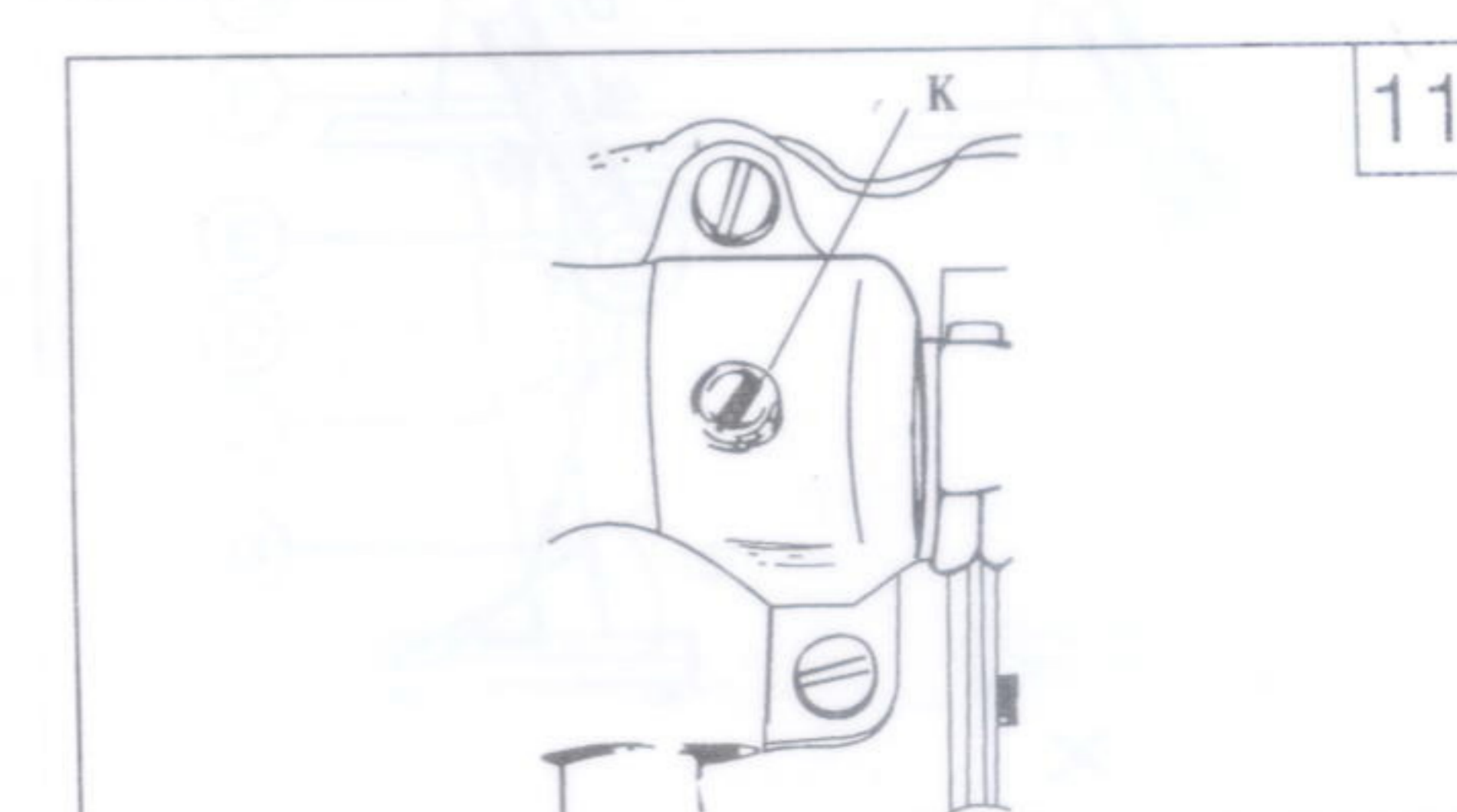
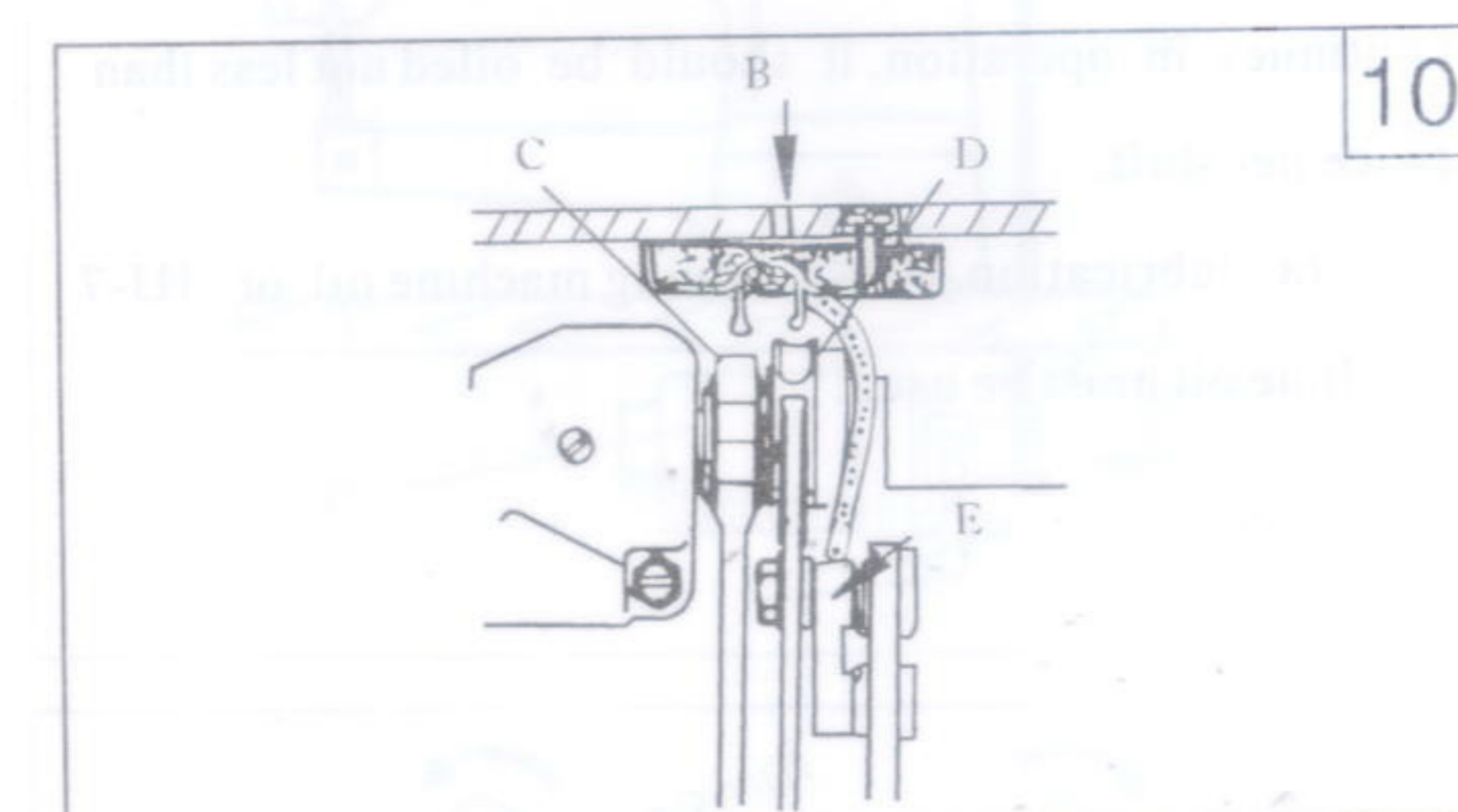
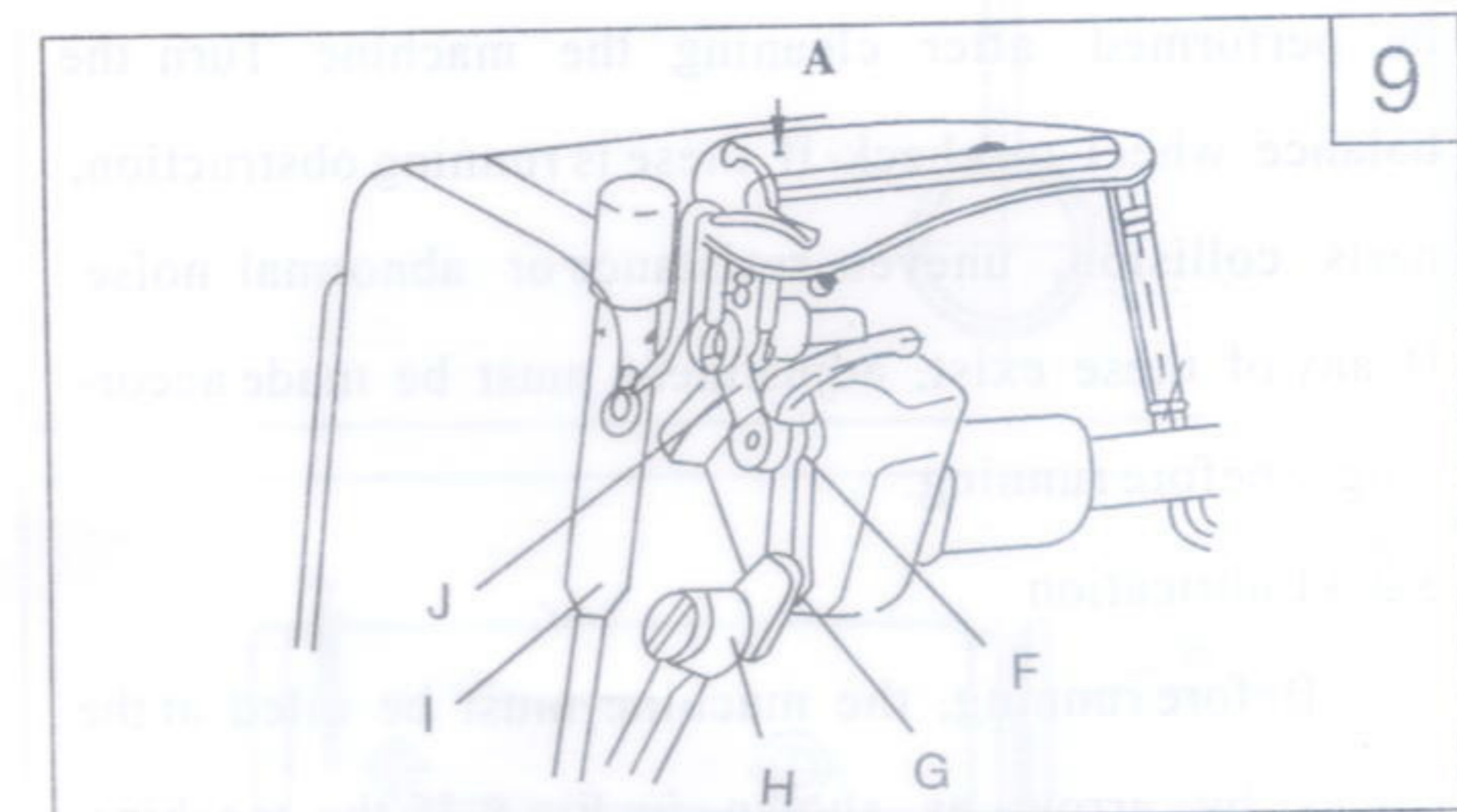
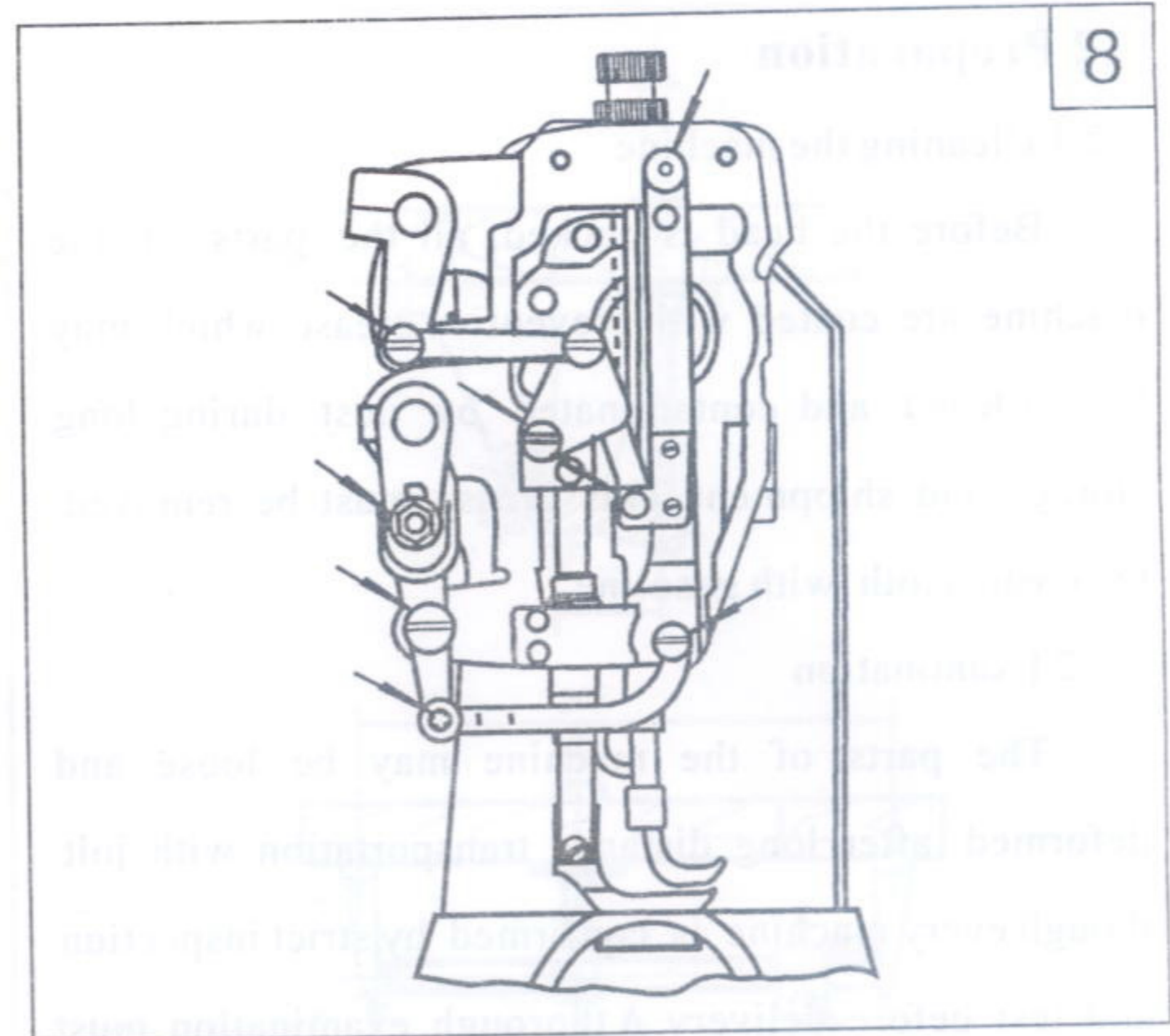

4. Operation

4.1 Selection of the thread

Needle thread should be left-twisted thread, For bobbin thread, either left or right twisted thread is available.

To identify the twist direction of the thread, hold the thread as shown in Fig.12, twist the thread by right hand in the direction as arrow shows. If the stand turns to be tight, the thread is the left-twisted thread, other wise it is right-twisted thread.



4.2 Coordination among the needle, the thread and the sewing material

Needle number is DP× 17, 135×.17 Nm 110-180 (#18~#24)

Selection to the needle size should be based upon the thread and materials to be sewn. As to the thread, refer to the following table, please.

The needle number should be suitable for the nature of material. If use needle of too small number to sew heavy and hard fabrics, the needle will be broken easily and will skip which will cause thread breakage. On the contrary, the material will be destroyed for the big needle hole. So the needle size and the thread should be selected properly according to the nature of material.

4.3 Installing the needle(Fig.13)

Turn the balance wheel to lift the needle bar to its highest point, loosen needle set screw 1, make the needle groove turn to the left side of an operator, fully insert the needle shank up to the bottom of needle socket, then tighten needle set screw 1.

Note: Fig.13(b) insufficient insertion,
Fig.13(c) wrong direction of groove

4.4 Winding the bobbin thread

4.4.1 Winding method(Fig.14)

Install bobbin A to the top of bobbin winder spindle B. Pass thread C from the spool through eye 1 on tension bracket E, then pass it between tension disc 2, and wind the end of the thread a few turns on the bobbin. Push stop latch thumb lever D down to lock the bobbin, the winder pulley F is thereby pressed on belt G.

Start the machine to wind. When the thread is fully wound, the bobbin winder stop latch will automatically release the bobbin winder, thus stopping the winding motion.(Be sure to keep the presser foot lifted when the thread is wound without operation.

12

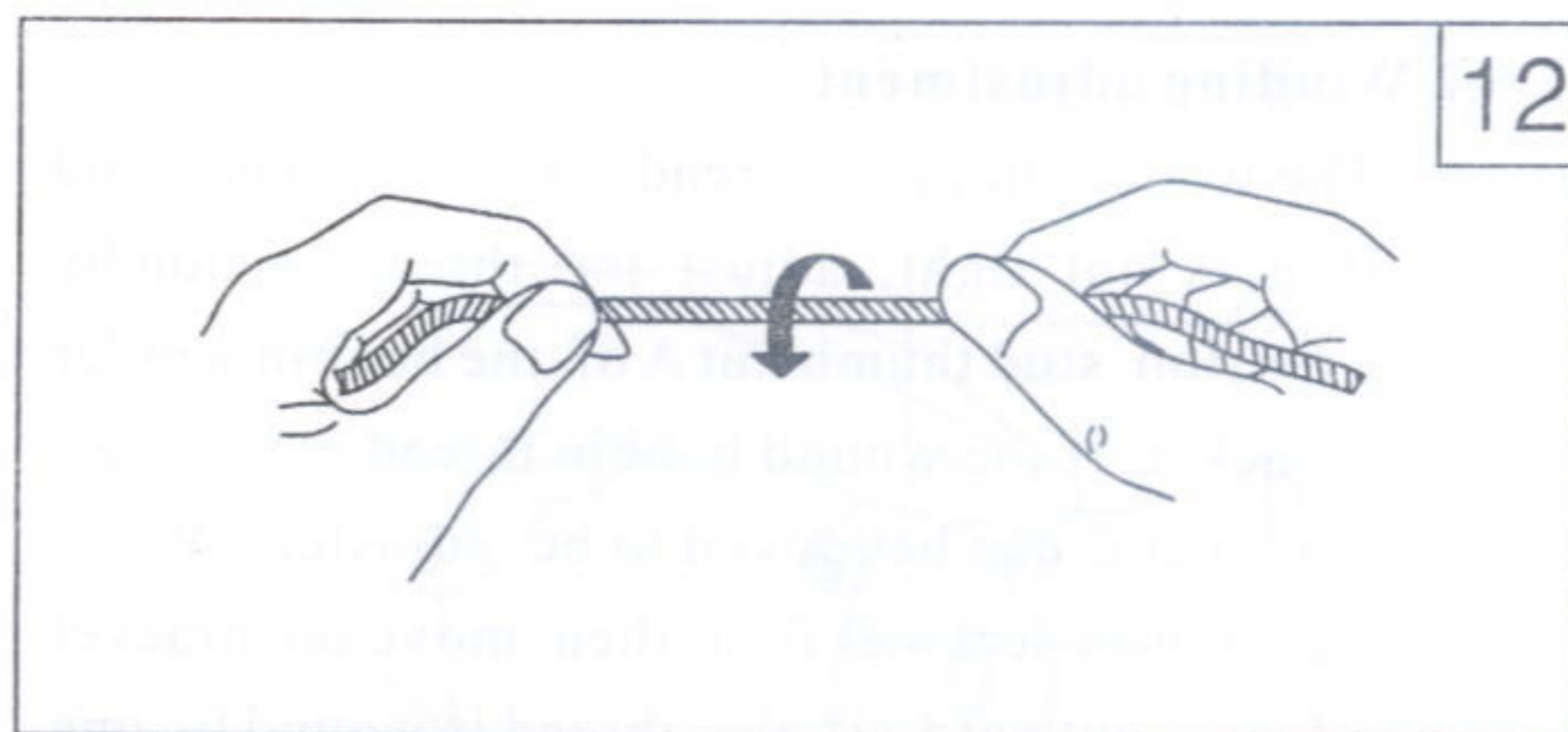

13

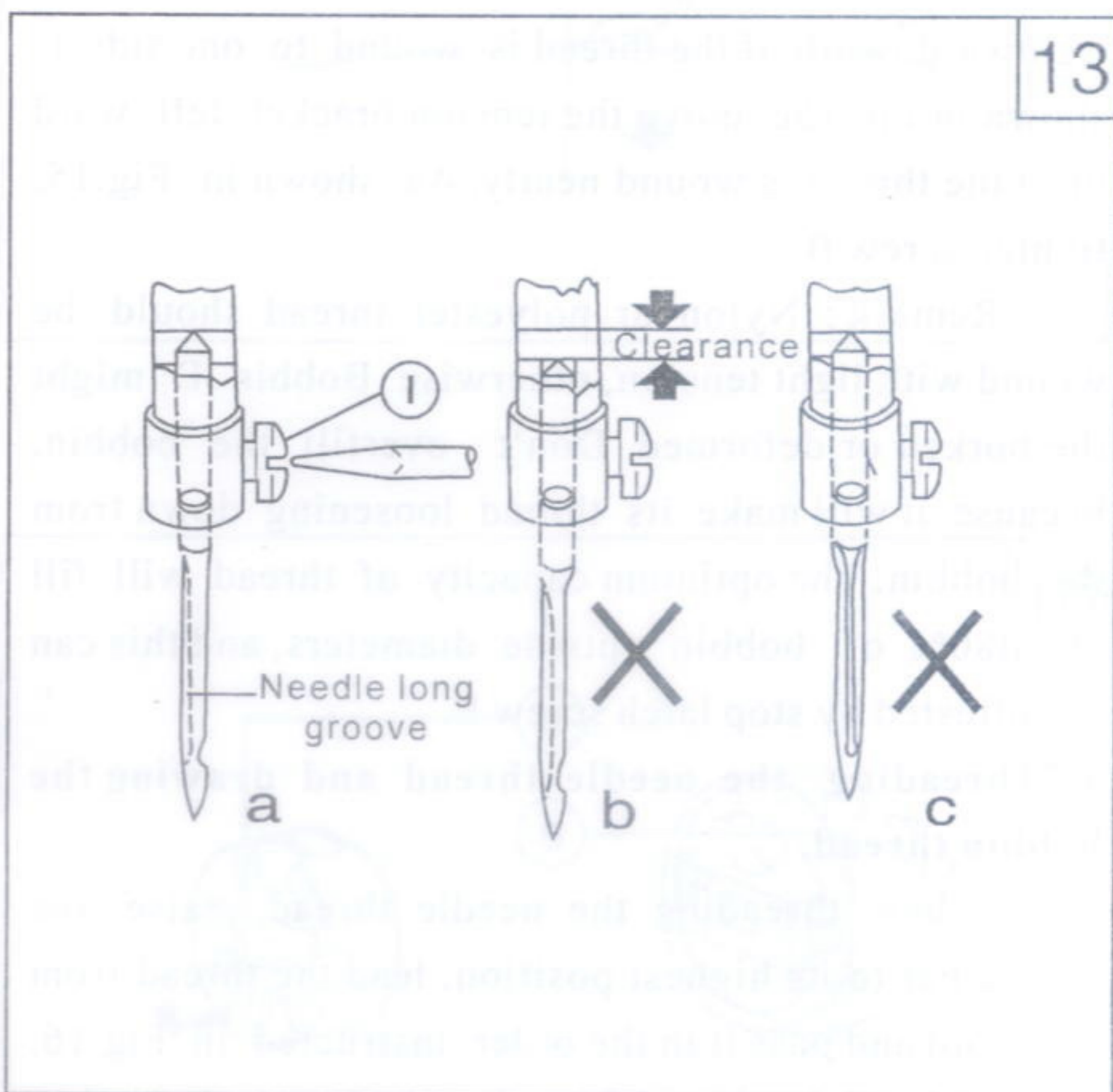

14

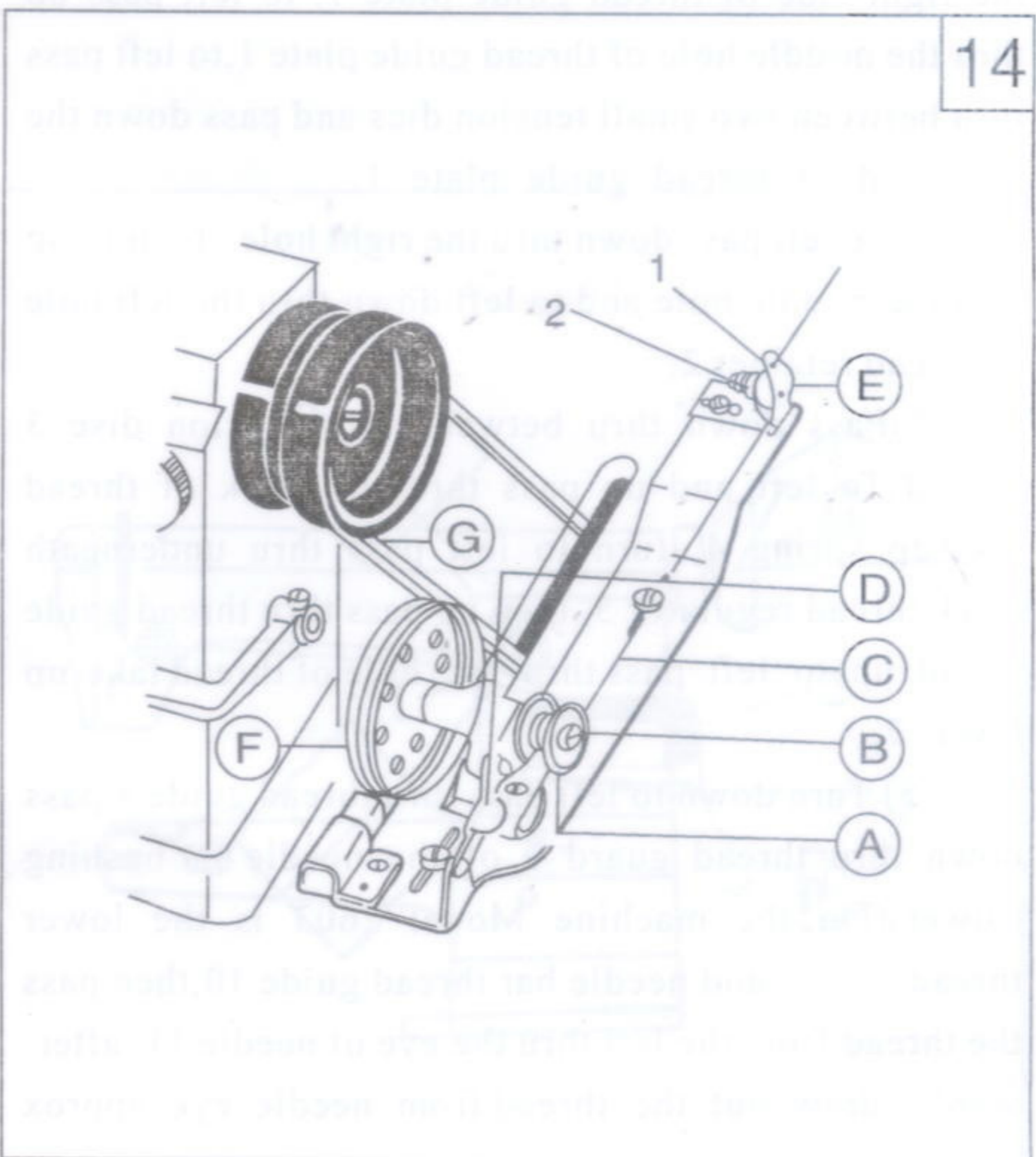

4.4.2 Winding adjustment

The wound bobbin thread should be neat and tight. If it is not tight, adjust the thread tension by turning tension stud thumb nut A of the bobbin winder tension bracket. If the wound bobbin thread is not neat, tension bracket C can be moved to be adjusted. When adjusting, loosen screw B first, then move the bracket left-ward or rightward. If the thread is wound to one side as shown in Fig.15b, move the tension bracket rightward, while if the thread is wound to one side as shown in Fig 15c, move the tension bracket left ward until the thread is wound neatly. As shown in Fig.15, tighten screw B.

Remark : Nylon or polyester thread should be wound with light tension, otherwise Bobbin D might be broken or deformed. Don't overfill the bobbin, because it will make its thread loosening down from the bobbin. The optimum capacity of thread will fill about 80% of bobbin outside diameters, and this can be adjusted by stop latch screw E.

4.5 Threading the needle thread and drawing the bobbin thread.

When threading the needle thread, raise the needle bar to its highest position, lead the thread from the spool and pass it in the order instructed in Fig.16.

1) Lead the thread from the spool, pass down thru the right side of thread guide plate 1, to left pass up thru the middle hole of thread guide plate 1, to left pass thru between two small tension discs and pass down the left hold of thread guide plate 1.

2) To left pass down thru the right hole, to left up thru the middle hole and to left down thru the left hole of thread retainer 2.

3) Pass down thru between two tension disc 3

4) To left and up pass thru the hook of thread take-up spring 4, turn to left pass thru underneath slack thread regulator 5, then up pass thru thread guide 6 and up to left pass thru the hole of thread take-up lever 7.

5) Turn down to left pass thru thread guide 8, pass down thru thread guard 9 of the needle bar bushing (lower) (On the machine Model 2603 is the lower thread guard) and needle bar thread guide 10, then pass the thread from the left thru the eye of needle 11, afterwards, draw out the thread from needle eye approx 100mm.

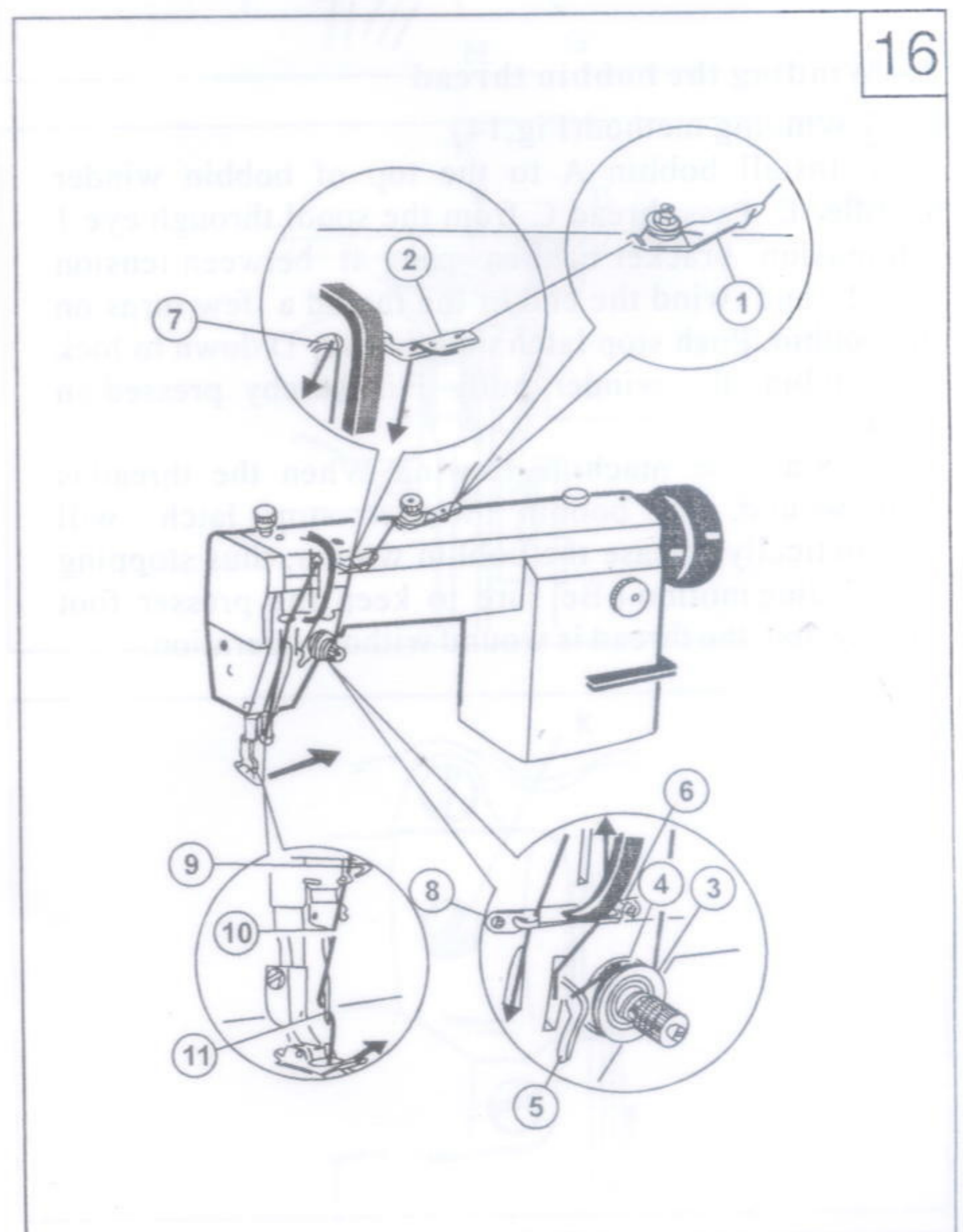
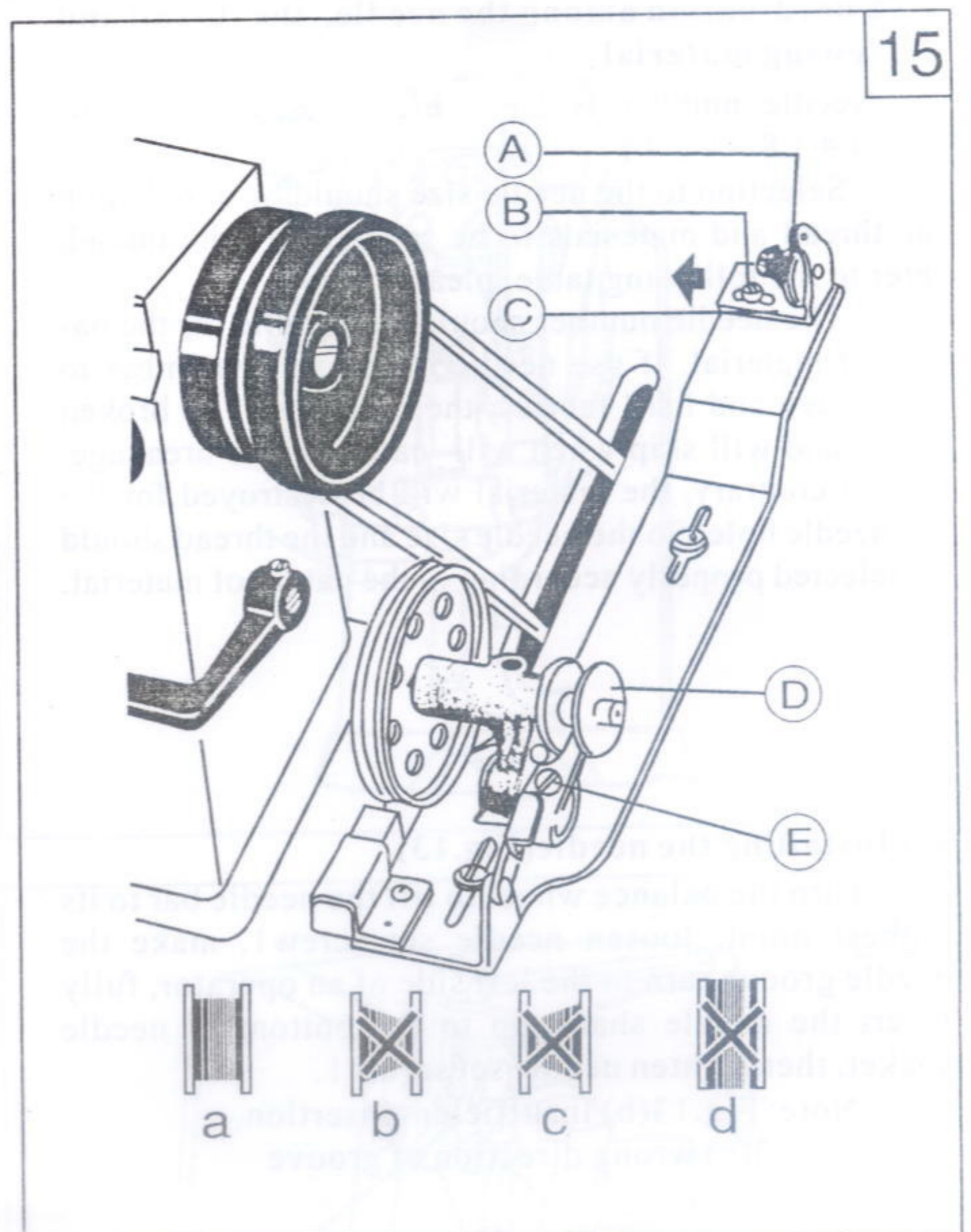

When drawing the bobbin thread, hold the tip of the needle thread by hand, turn the balance wheel to lower the needle bar and then, to lift it to its highest position, Pull the needle thread and then the bobbin thread is drawn up. Put the tips of the needle and bobbin thread toward front under the presser foot.

4.6 Setting the bobbin (Fig.17)

Put bobbin B into bobbin case, pass thread E thru slit C to lead it under-neath the bobbin case tension spring D and out at the notch of the spring, draw out thread about 100mm.

Remark: The bobbin case must be rotating clockwise when thread E is drawn. If not, reverse bobbin B.

4.7 Installing the bobbin case(Fig.18)

Lift the needle bar to its highest position and open the bed slide. Fully lift bobbin case latch lever A, holding it by fingers, then install the bobbin case into rotating hook B as shown in Fig.18. Make sure that the bobbin case latch is engaged in the position groove of rotating hook spindle.

When remove the bobbin case from the rotating hook, fully lift bobbin case latch lever A holding it by fingers first, so as to prevent the bobbin from dropping out of the bobbin case, then gently take the bobbin case out.

4.8 Setting stitch length and reverse sewing (Fig.19)

Stitch length can be set by turning stitch length regulating dial 1. The stitch length is longer when turning stitch length regulating dial 1 Counterclockwise, and the stitch length is shorter when turning dial 1. Clockwise. Reverse sewing can be obtained when feed reverse lever 2 is depressed. And forward sewing can be restored automatically when feed reverse lever 2 is released.

5. Adjusting the thread tension

In general, the thread tension is to be adjusted in accordance with materials, thread and others.

In practice, the thread tension is adjusted according to the stitches resulted. The needle thread tension should be adjusted with reference to the bobbin thread tension. When adjusting the bobbin thread tension, turn bobbin case tension spring screw A (see Fig.20)clockwise for more tension or turn the screw counterclockwise for less tension.

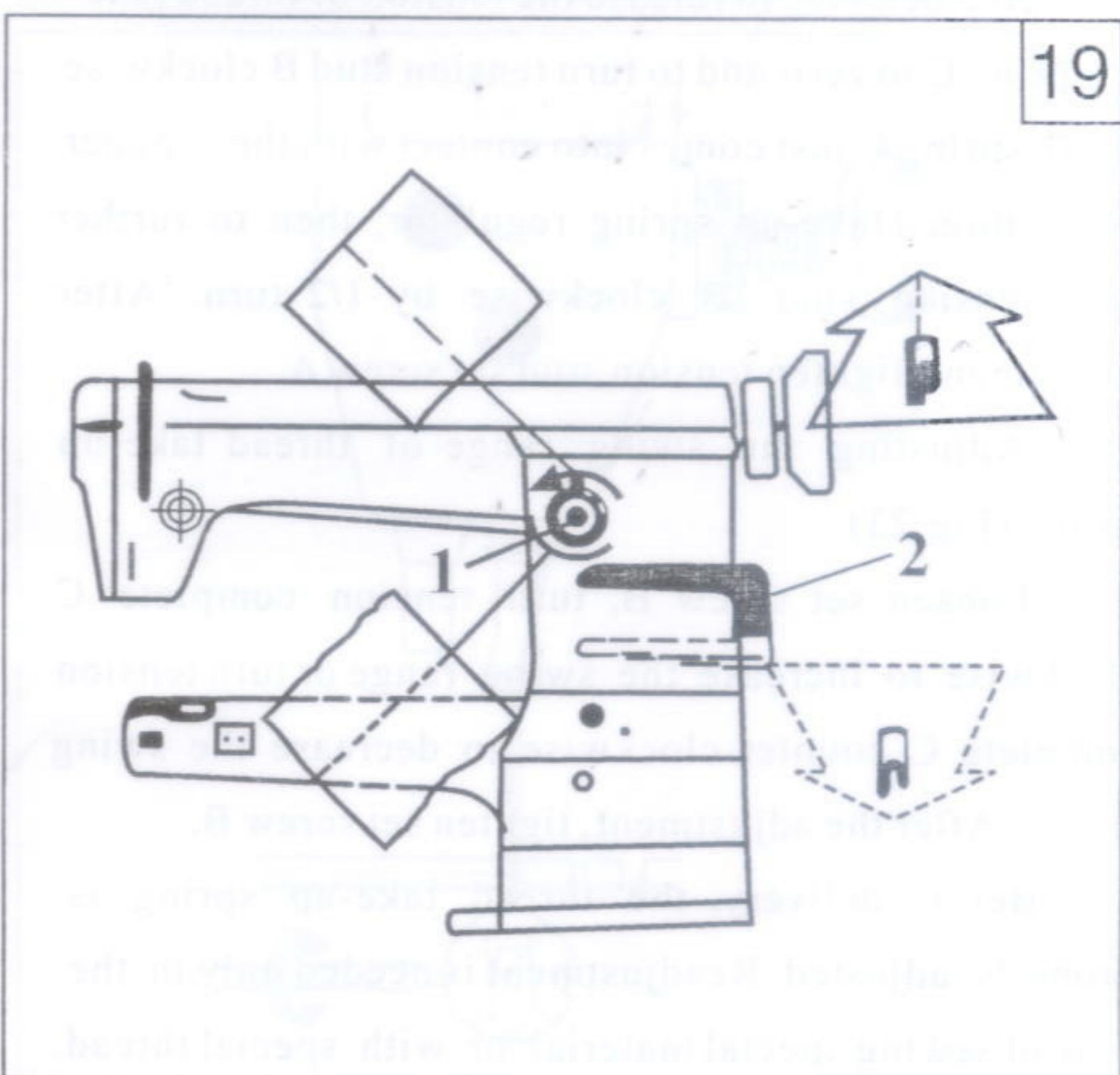
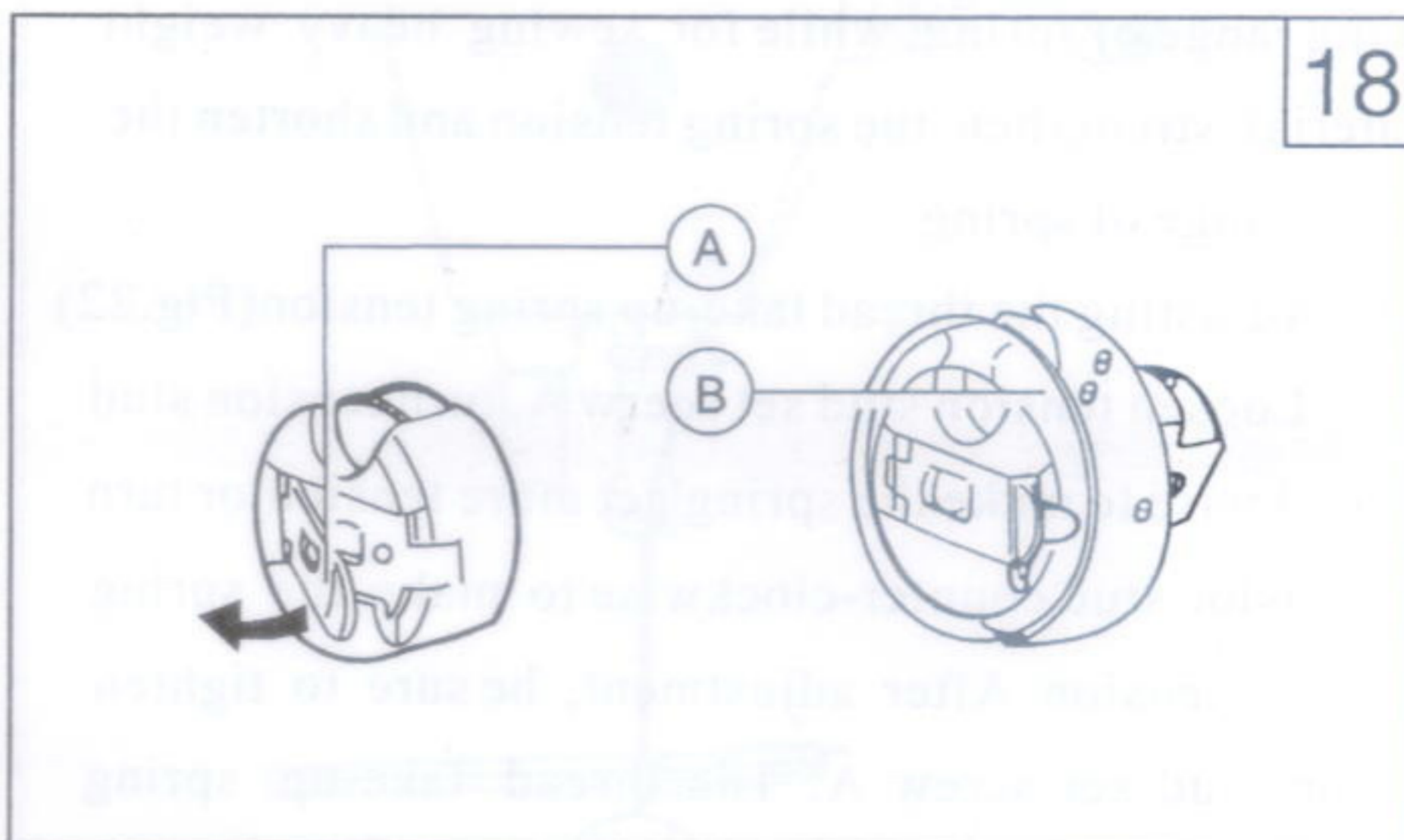
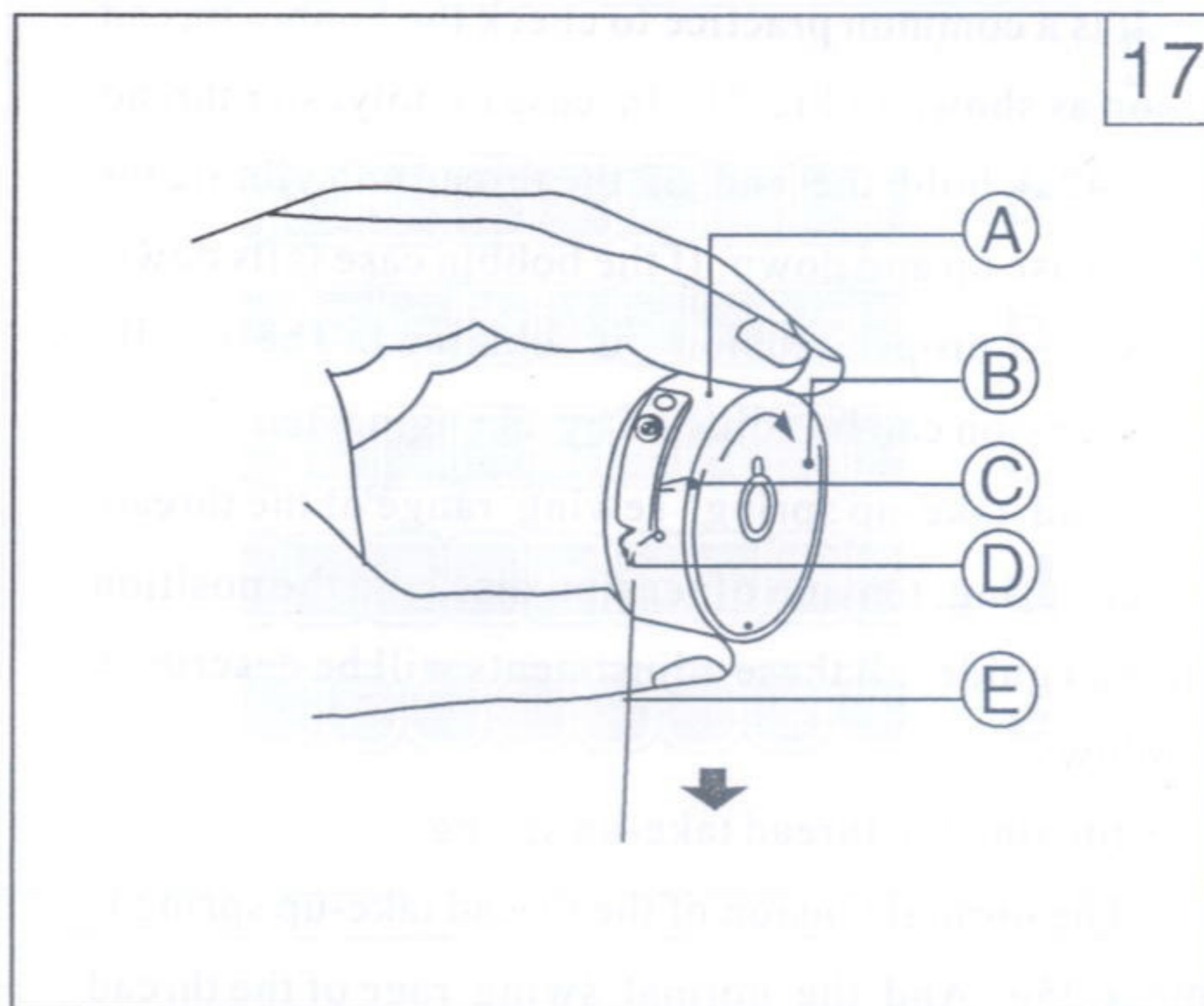

It is a common practice to check the bobbin thread tension as shown in Fig.21. In case of polyester thread 14 tex(42s), hold the end of the thread and vibrate the bobbin case up and down. If the bobbin case falls down slowly, the proper tension is obtained. The needle thread tension can be adjusted by changing tension of the thread take-up spring, sewing range of the thread take-up spring, tension of tension disc, and the position of thread guide, all these adjustments will be described as follows.

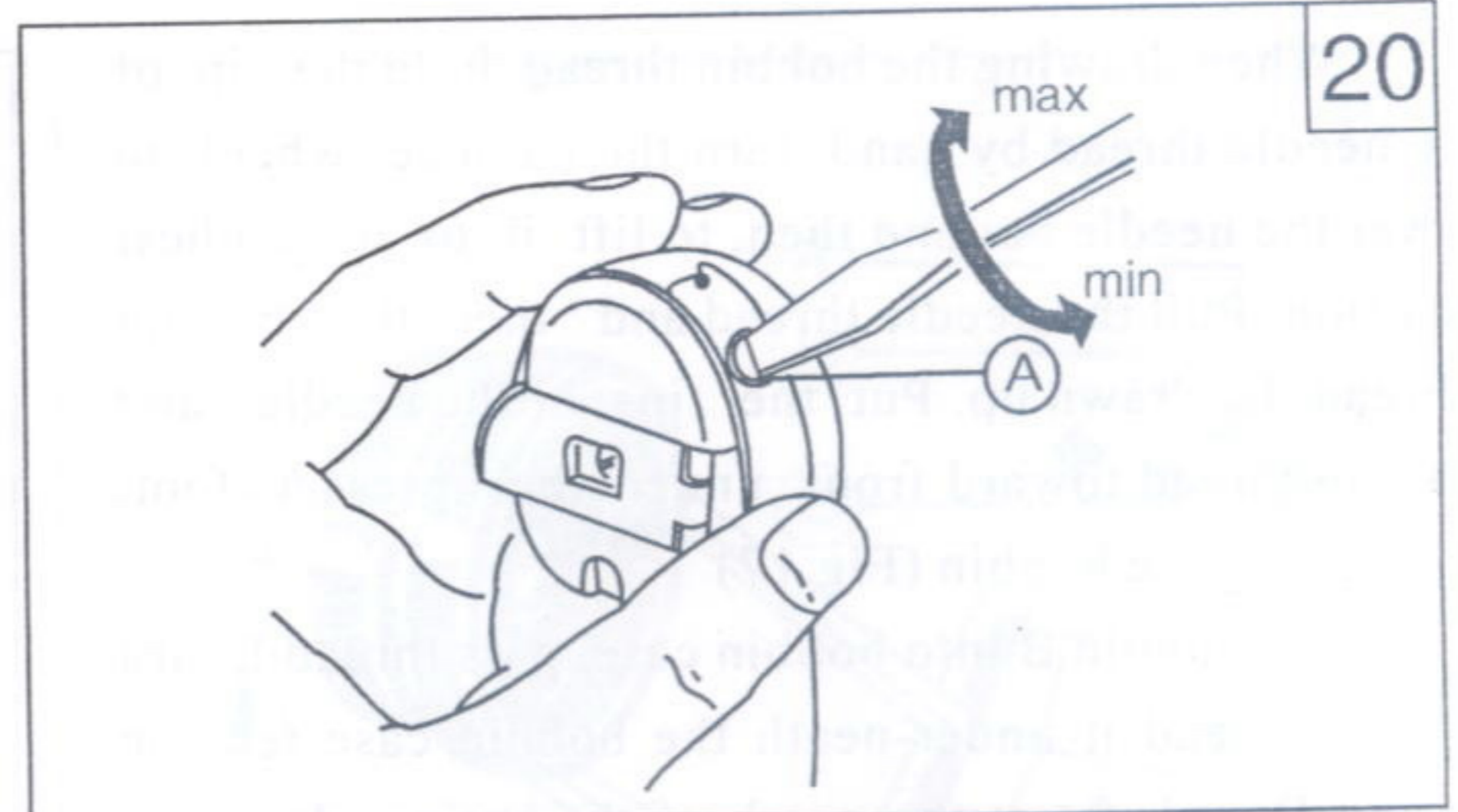

5.1 Adjusting the thread take-up spring

The normal tension of the thread take-up spring is approx.25g. And the normal swing range of the thread take-up spring is 5-8mm. For sewing light weight materials, weaken the spring tension and widen the swing range of spring, while for sewing heavy weight material, strengthen the spring tension and shorten the swing range of spring.

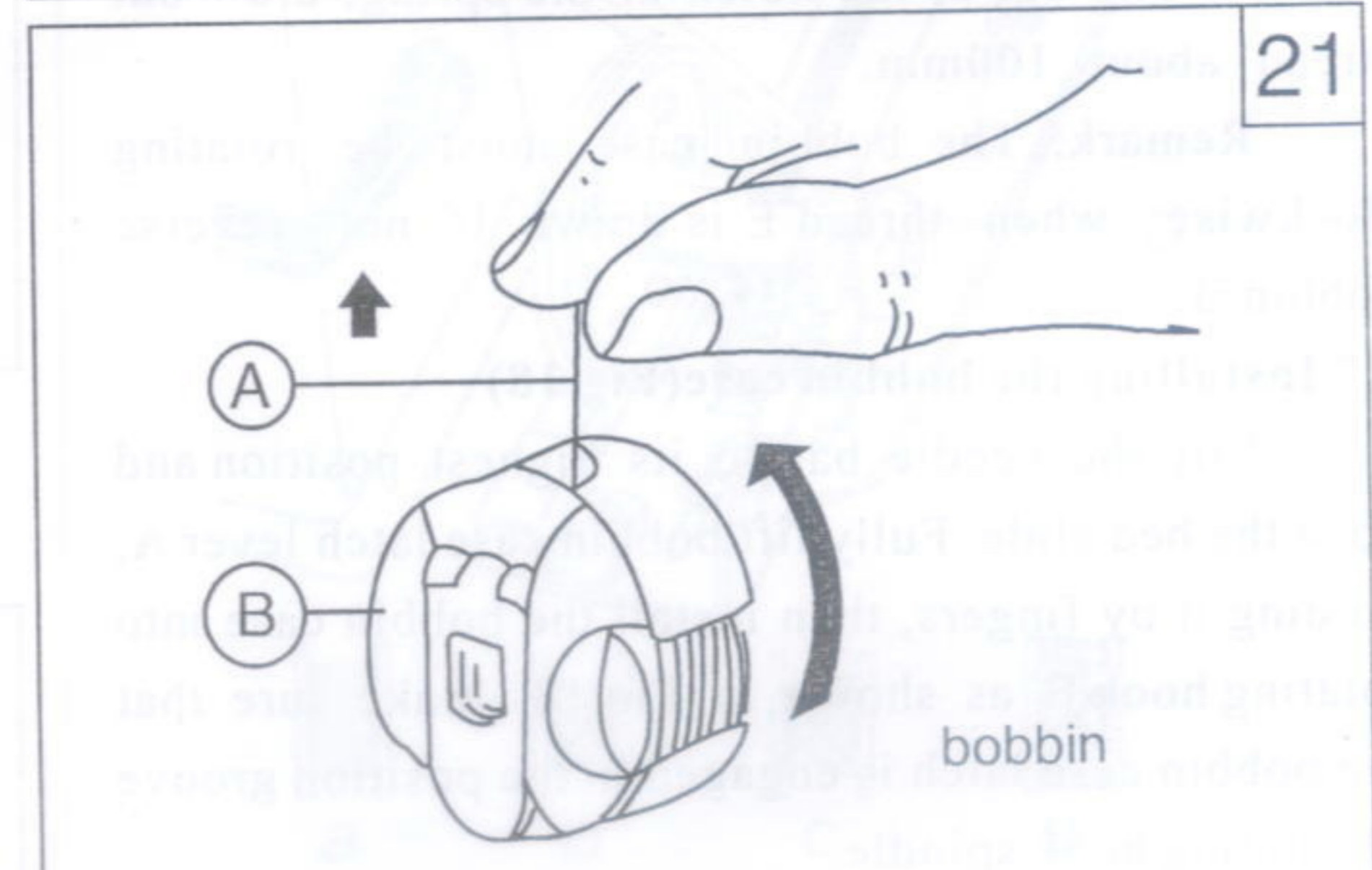

5.1.1 Adjusting the thread take-up spring tension(Fig.22)

Loosen tension stud set screw A, turn tension stud B clockwise to make the spring get more tension, or turn the tension stud counter-clockwise to make the spring get less tension. After adjustment, be sure to tighten tension stud set screw A. The thread take-up spring tension is about 25g. The method of adjustment is to loose set screw A first, then to turn tension stud B counter-clockwise to release the tension of thread take-up spring C to zero, and to turn tension stud B clockwise until spring C just comes into contact with the stopper on the thread take-up spring regulator, then to further turn tension stud B clockwise by 1/2 turn. After adjustment, tighten tension stud set screw A.

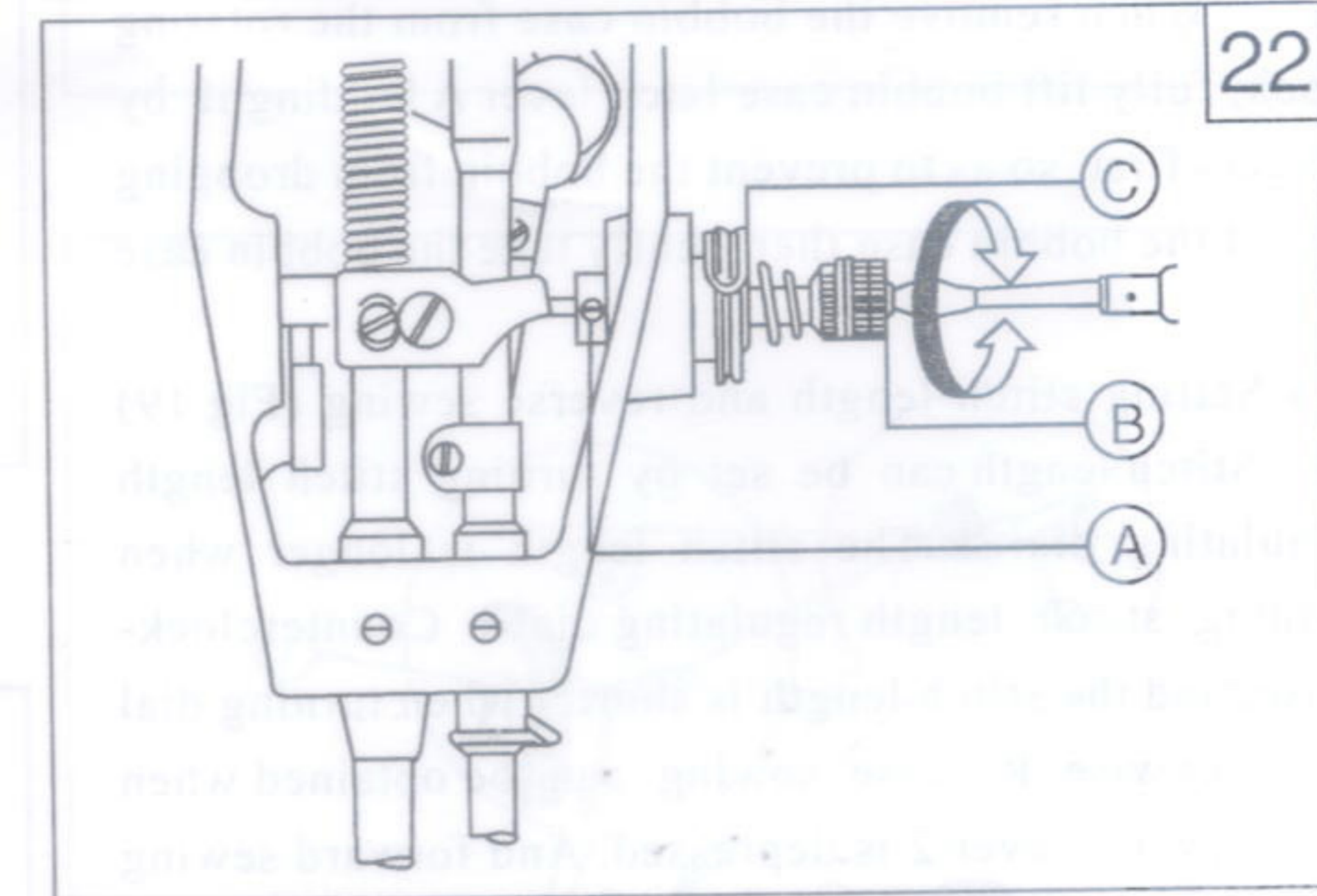

5.1.2 Adjusting the swing range of thread take-up spring (Fig.23)

Loosen set screw B, turn tension complete C clockwise to increase the swing range or turn tension complete C counter-clockwise to decrease the swing range. After the adjustment, tighten set screw B.

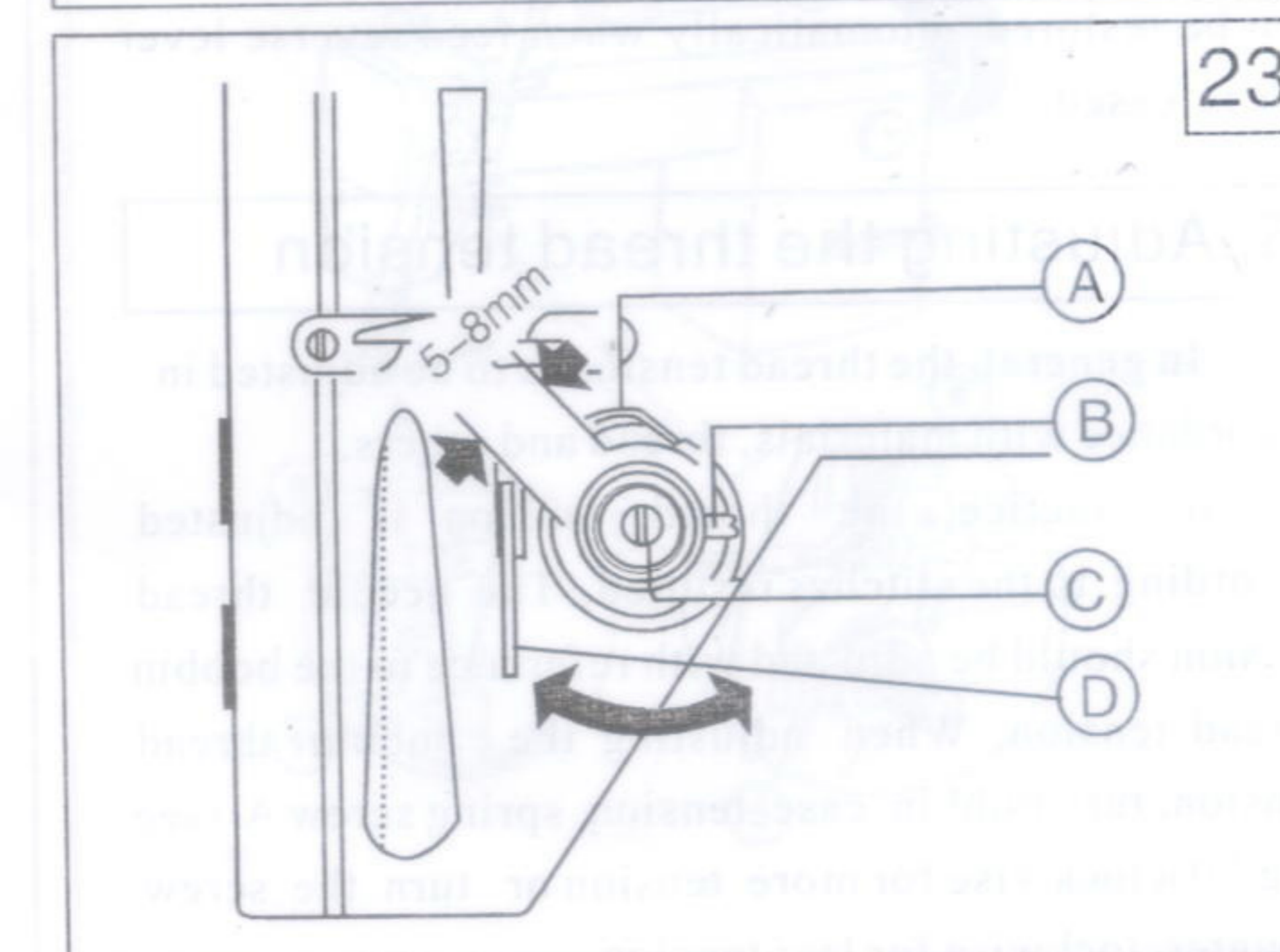

Before delivery, the thread take-up spring is properly adjusted. Readjustment is needed only in the case of sewing special material or with special thread.

5.2 Adjusting the thread guide

The position of the thread guide affects sewing quality, so it must be adjusted according to the materials to be sewn.

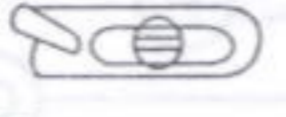
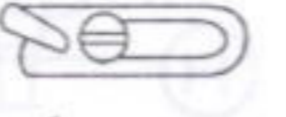
	1	2	3
Thread guide Position	 Leftward	 Center	 Rightward
Material Weight	Heavy	Medium	Light

5.3 Adjusting the tension of needle thread and bobbin thread

Fig.24 shows the various type of stitch forms probably to happen when sewing.

Normal stitch form should be as shown in Fig.24a. When abnormal stitches occur with puckering, loose stitch or thread breakage, the tension of needle thread and bobbin thread must be adjusted accordingly.

Fig.24b shows the needle thread tension is too strong or the bobbin thread tension is too weak. Turn the tension regulating thumb nut counter-clockwise to make the needle thread get less tension or tighten the bobbin case tension regulating screw to make the bobbin thread get more tension (see Fig.25).

Fig. 24c shows the needle thread tension is too weak or the bobbin thread is too strong, turn the tension regulating thumb nut clockwise to make the needle thread get more tension or turn the bobbin case tension regulating screw counter-clockwise to make the bobbin thread get less tension (see Fig.26).

Fig.24d、e shows other abnormal stitches, adjustment can be made with reference to the above means.

24

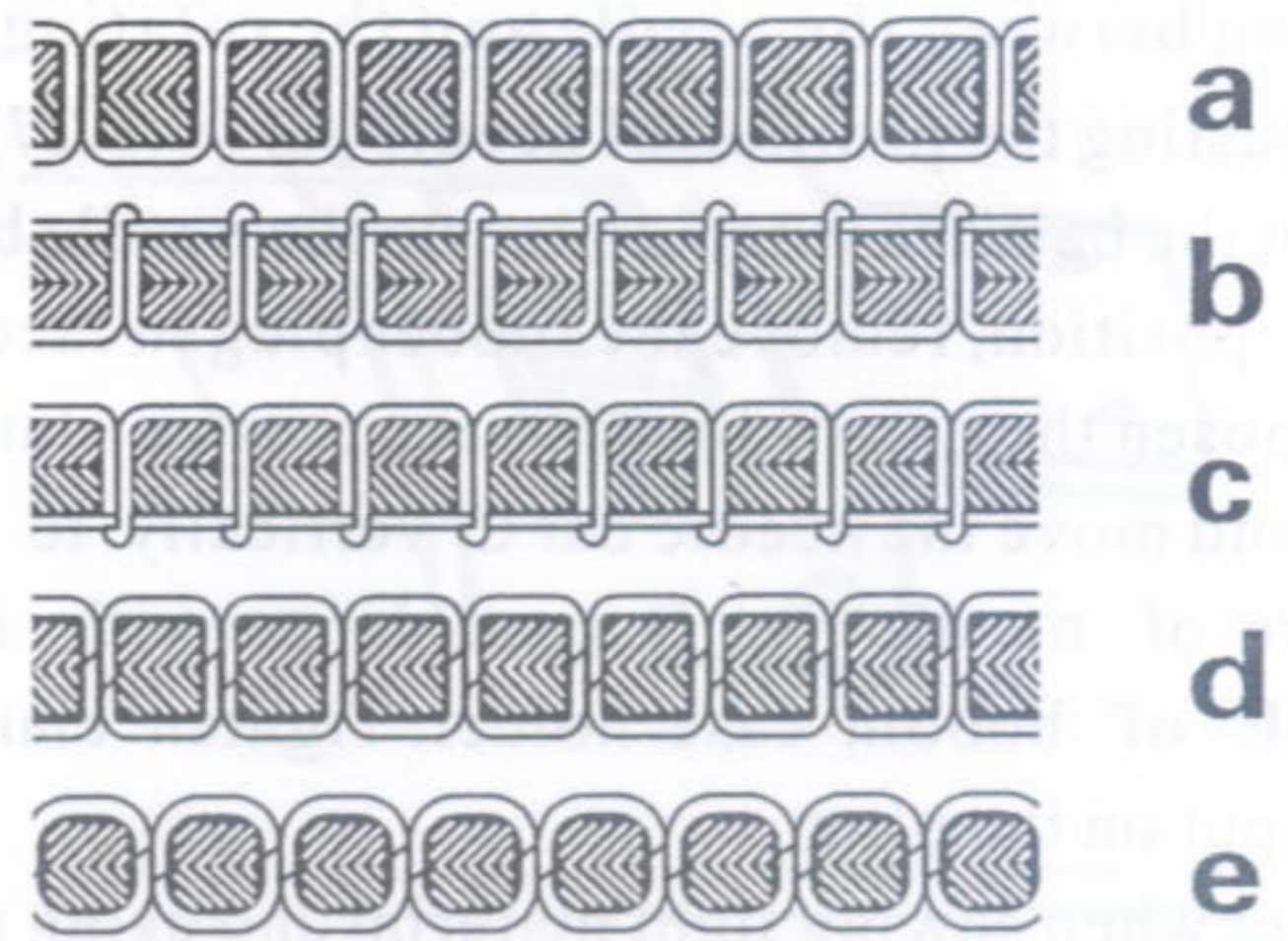

25

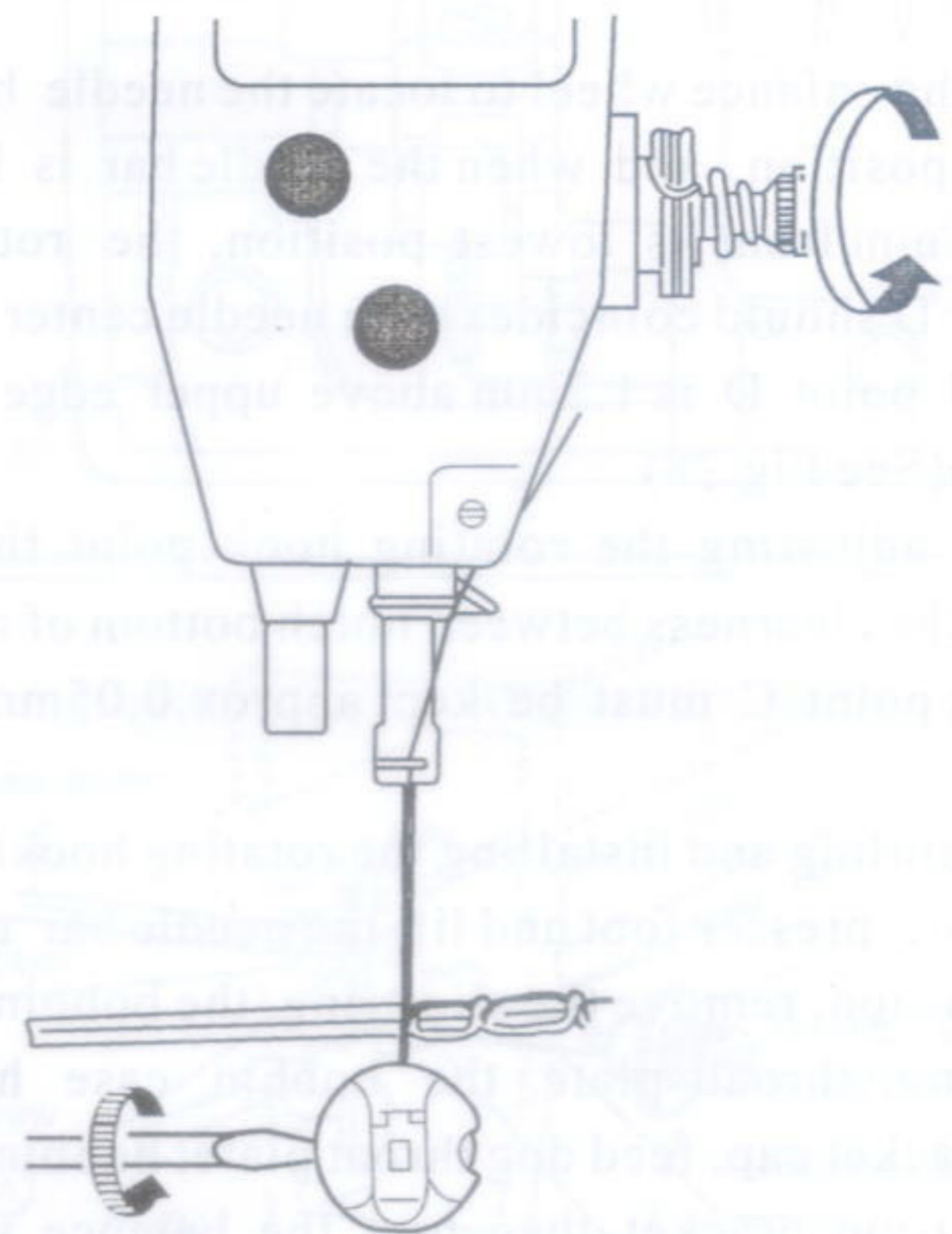

26

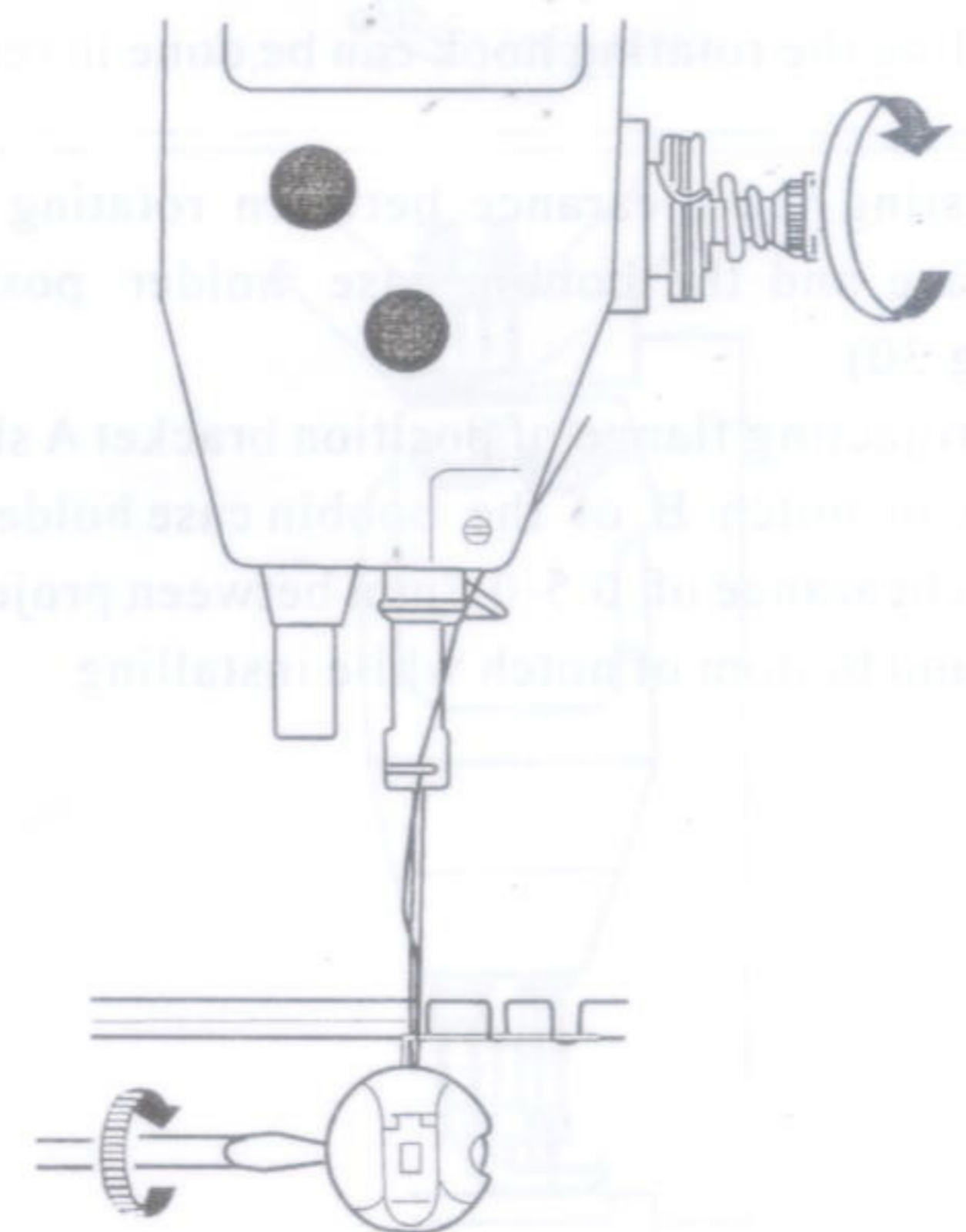

6. Adjustment

6.1 Timing between the needle and the rotating hook

6.1.1 Adjusting the position of needle bar (Fig.27)

Turn the balance wheel to locate the needle bar at its lowest position, remove the rubber plug in face plate A, then loosen the needle bar connecting stud clamping screw B and move the needle bar C vertically to make the centre of needle eye D coincide with inside surface E of bobbin case holder. Tighten clamping screw B, put on the plug.

Note: when sewing light material and using nylon, polyester fabrics, the needle timing position is 0.5mm above the standard timing position.

6.1.2 Adjusting the rotating hook point timing with the needle.

Turn the balance wheel to locate the needle bar at its lowest position, and when the needle bar is lifted again at 2.5mm from its lowest position, the rotating hook point D should coincide with needle center line C, and hook point D is 1.2mm above upper edge E of needle eye. (See Fig.28)

When adjusting the rotating hook point timing, make sure the clearness between notch bottom of needle D and hook point C must be kept approx.0.05mm (see Fig.29).

6.1.3 Dismantling and installing the rotating hook (F.30)

Lift the presser foot and lift the needle bar to its highest position, remove the slide ring, the bobbin case, back-up ring, throat plate, the bobbin case holder position bracket cap, feed dog throat plate, bobbin case holder position bracket, then turn the balance wheel and loosen three set screw D of the rotating hook, At last, take it down slowly with hand.

Installing the rotating hook can be done in reverse sequence.

6.1.4 Adjusting the clearance between rotating hook inner surface and the bobbin case holder position bracket (Fig.30)

The projecting flange of position bracket A should be engaged in notch B of the bobbin case holder, and maintain a clearance of 0.5-0.7mm between projecting flange top and bottom of notch while installing.

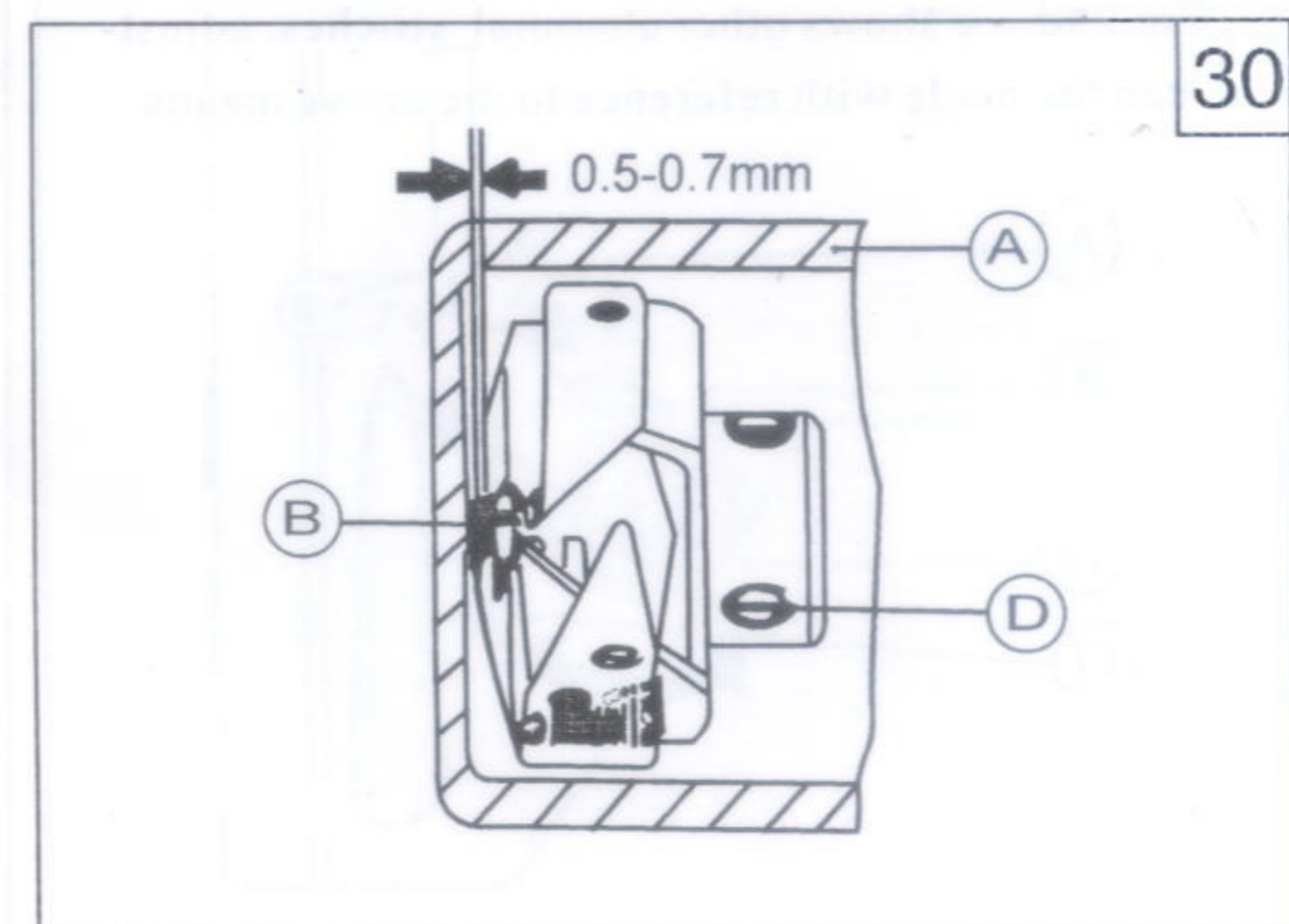
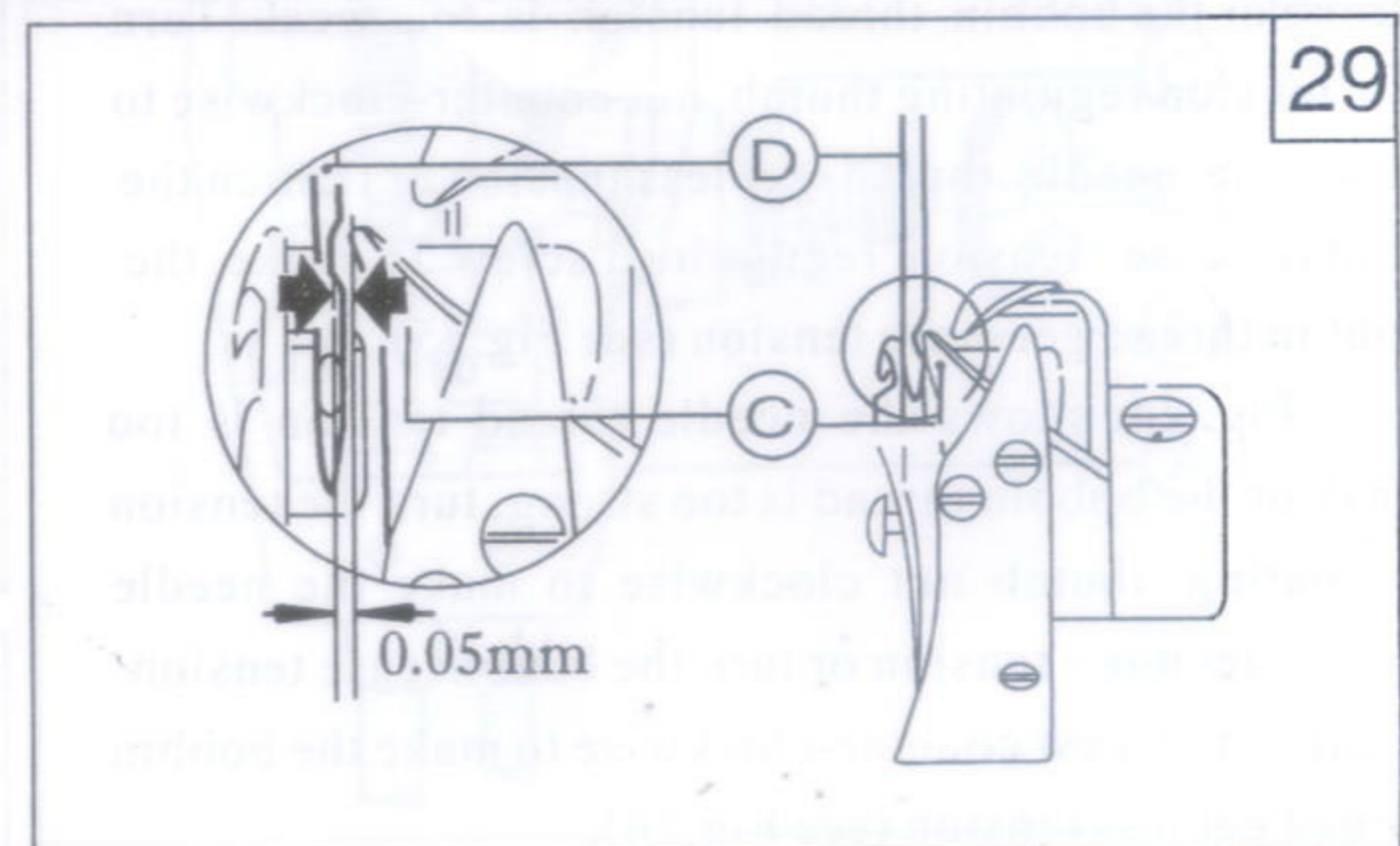
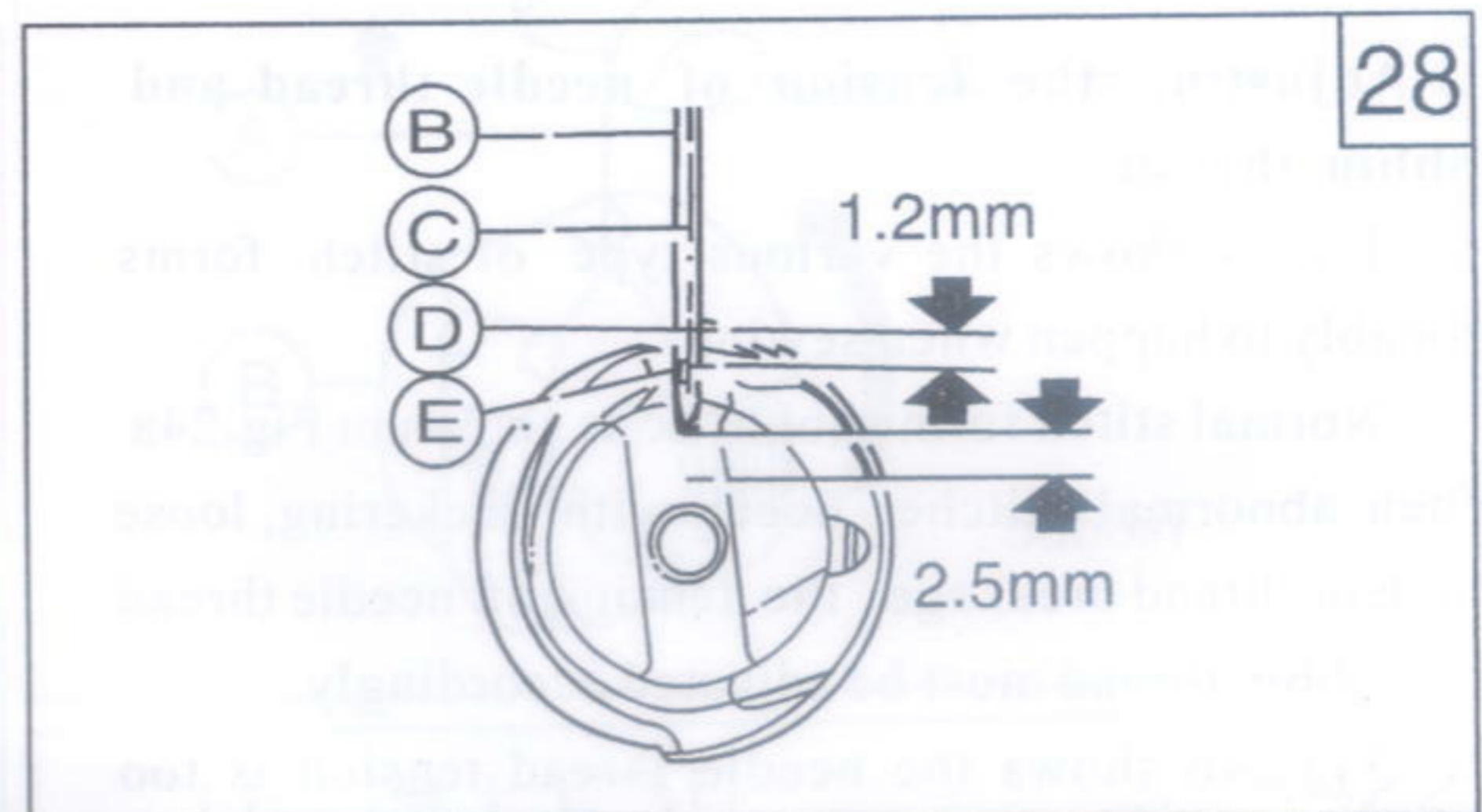
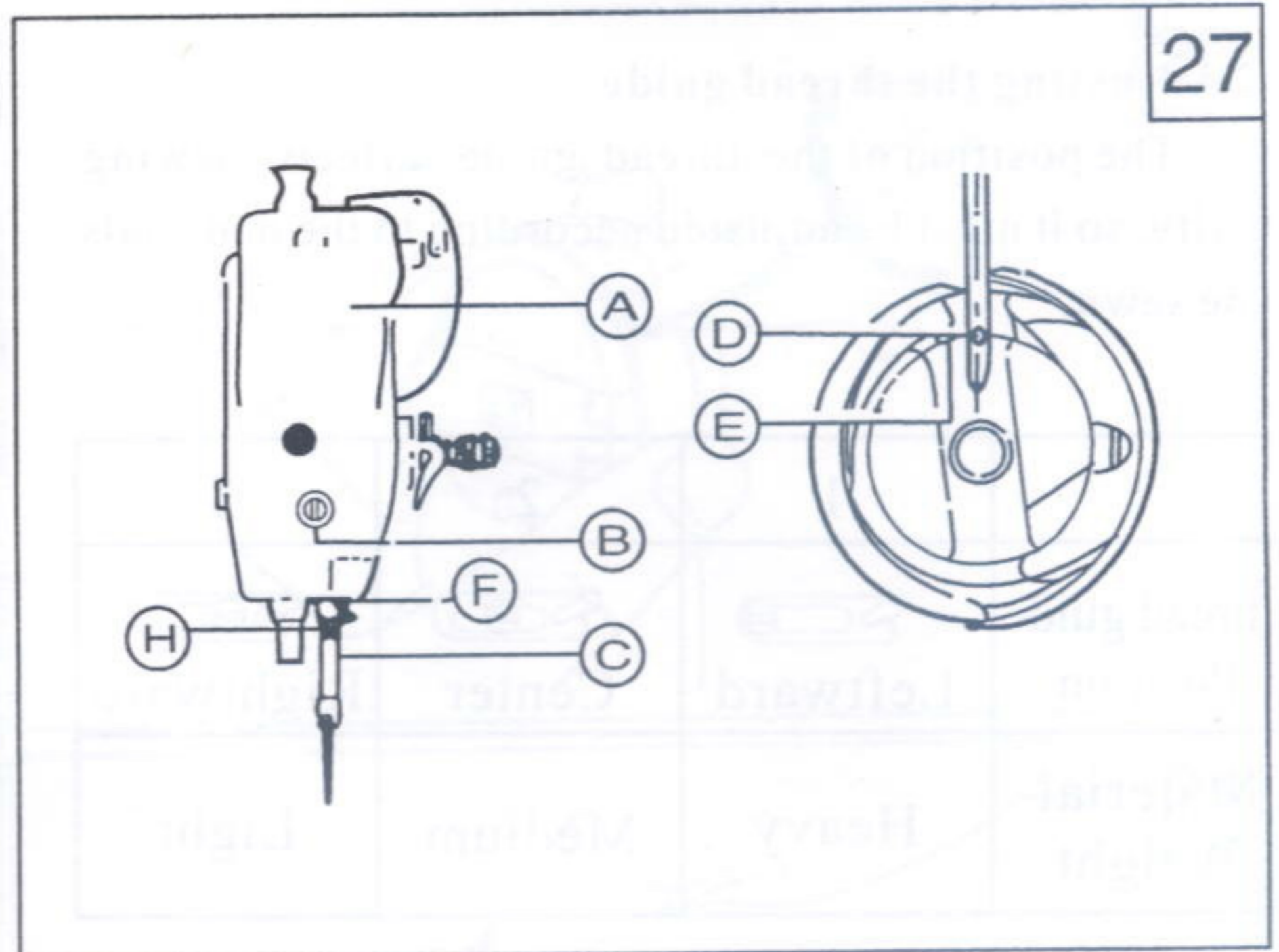

6.2 Adjusting the position of the feed dog (Fig.31)

The standard position of the feed dog is that the clearance from the throat plate slit to the front end D of the fully advanced feed dog is 1.5mm. When adjusting, fix the feed dog in the position where the feed dog fully advances. Then loosen feed rock shaft crank clamping screw A slightly (see Fig.31) and move the feed bar to adjust the clearness between the feed dog and the thread plate. After that, tighten clamping screw A.

6.3 Adjusting the tension releasing mechanism(Fig.32)

The tension discs should be pushed apart to open when the presser foot is lifted. But the open timing of the tension discs can be adjusted. When adjusting, first remove the rubber plug at the rear side of the arm and loosen screw A of the knee lifting lever(left), then the tension releasing cam can be moved leftward or rightward. When the cam is moved rightward, it is later to open, otherwise it is earlier to open.

6.4 Adjusting the pressure of presser foot(Fig.33)

Pressure on presser foot is to be adjusted in accordance with the materials to be sewn. Loosen lock nut B, first, if heavy materials to be sewn, turn pressure regulating thumb screw A clockwise as shown 34 to increase the pressure. While light materials to be sewn, turn the pressure regulating thumb screw A, a, counter-clockwise to decrease the pressure on presser foot, then tighten lock nut B.

6.5 Timing feed adjustment

The feed is well adjusted before machine leaving off factory. Adjust if necessary as follows:

Lift presser foot, turn the dial to the max. Turn balance wheel slowly to observe if the needle fall into the symmetric center of feed dog hole. If not, loosen the screw and turn the motion shaft to adjust it with reference to Fig.37a. After adjustment tighten the screw.

Go on turning the balance wheel, make needle advance a stitch length. At the moment, if the needle is at the center of feed dog hole, see Fig.34B, then the unison feed is got, if at D, then upper feed amount too much, if at C, then too small. Both should be adjusted. When adjusting, loosen the nut (Fig.35) and change the center gauge A. Increase A to increase upper feed amount, reduce A to reduce upper feed amount. After adjustment, tighten the nut.

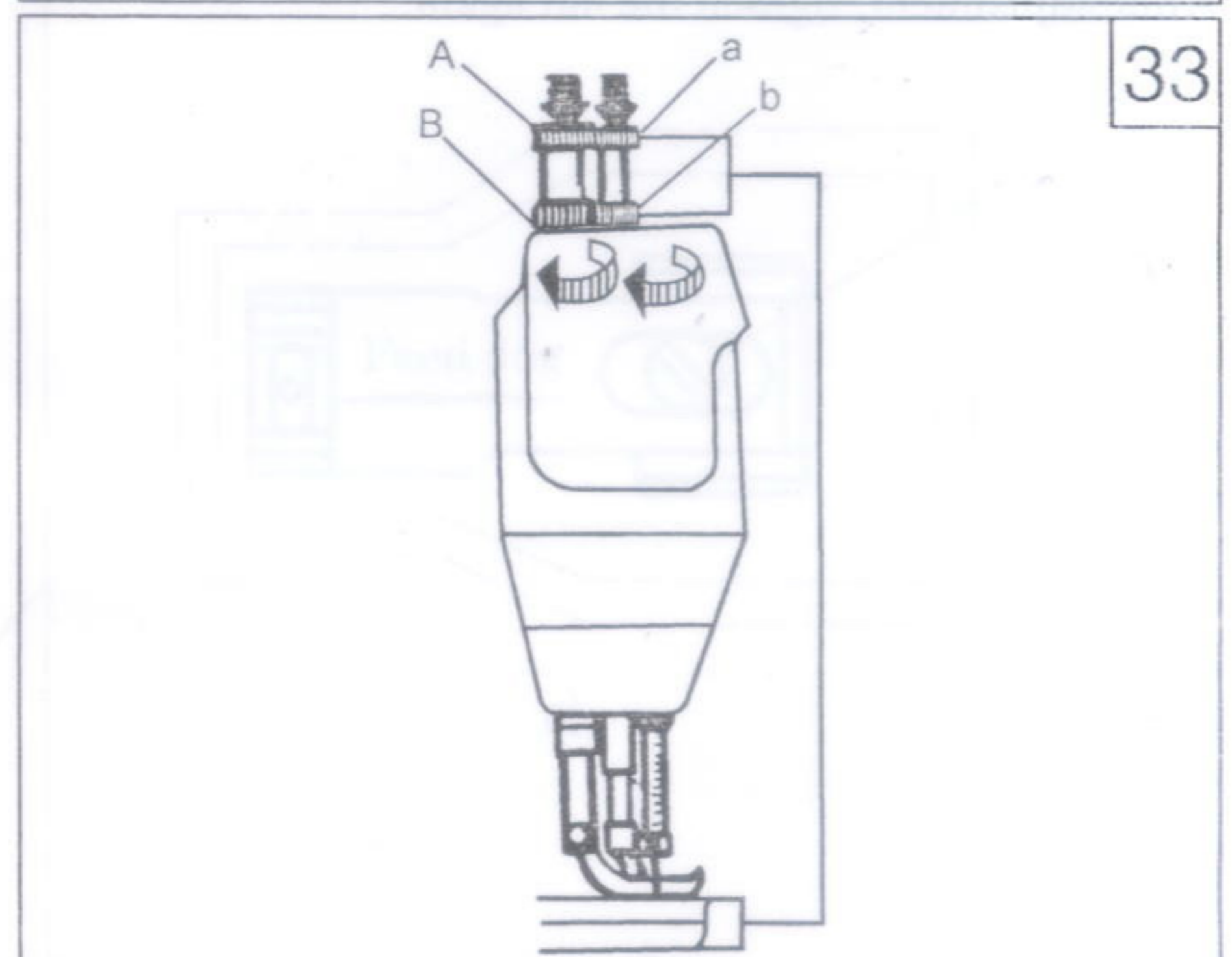
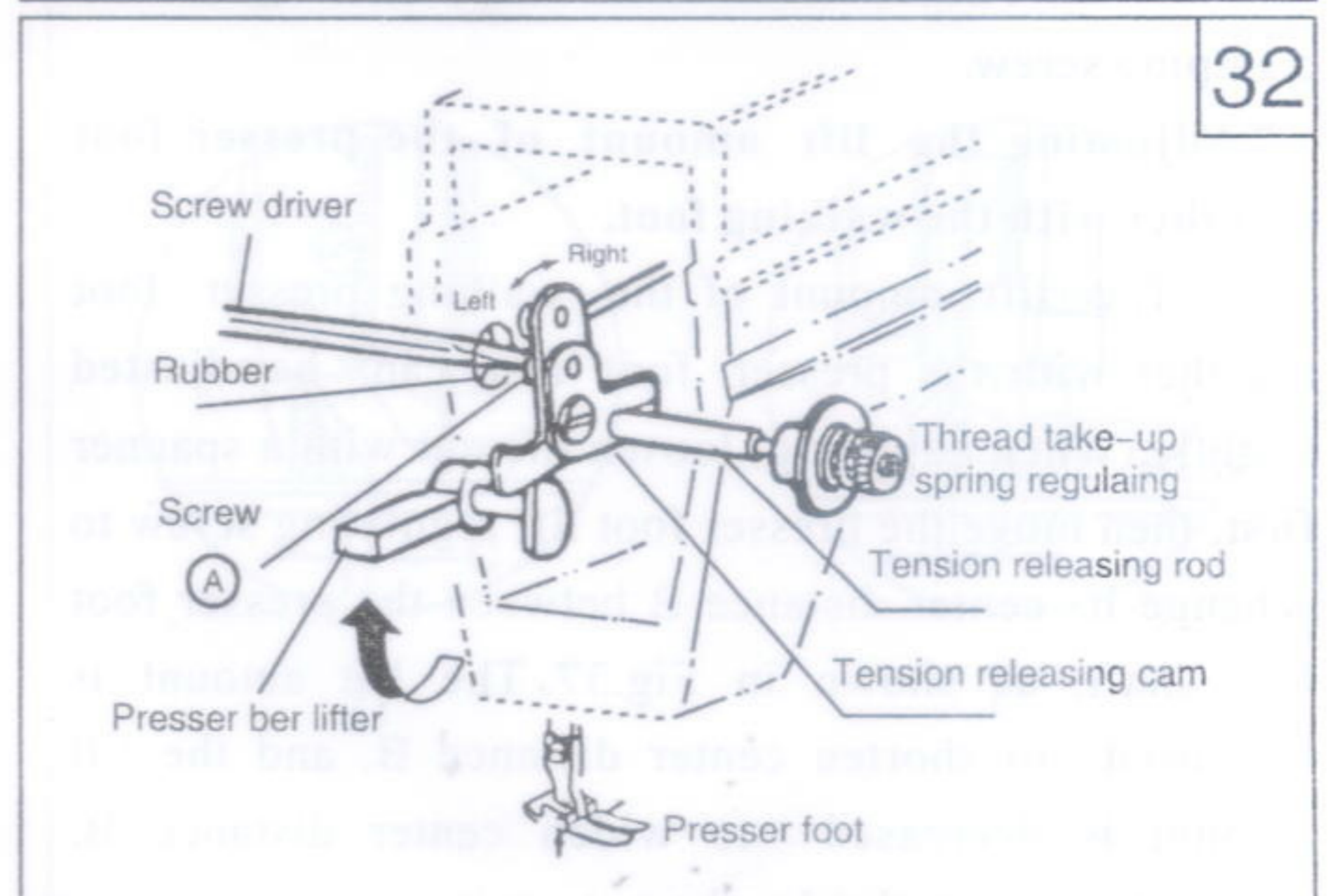
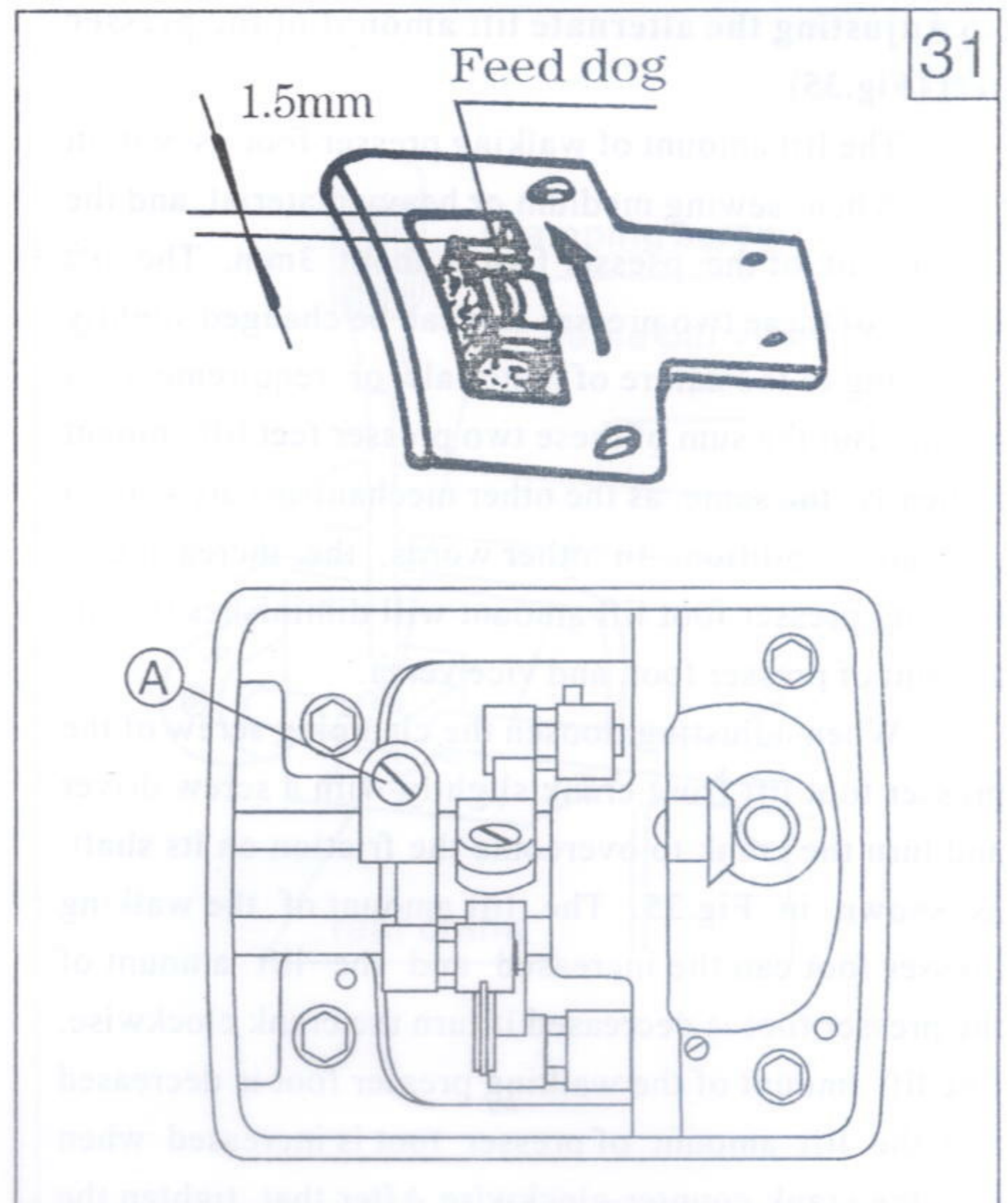

6.6 Adjusting the alternate lift amount of the presser feet (Fig.35)

The lift amount of walking presser foot is within 5mm. When sewing medium or heavy material, and the lift amount of the presser foot is about 3mm. The lift amount of these two presser feet can be changed slightly according to the nature of materials or requirements in sewing. But the sum of these two presser feet lift amount is nearly the same, as the other mechanisms are kept in constant condition. In other words, the increasing of walking presser foot lift amount will diminishes the lift amount of presser foot, and vice versa.

When adjusting, loosen the clamping screw of the presser foot lift front crank slightly with a screw driver and turn the crank to overcome the friction on its shaft, as shown in Fig.35. The lift amount of the walking presser foot can be increased and the lift amount of the presser foot is decreased if turn the crank clockwise. The lift amount of the walking presser foot is decreased and the lift amount of presser foot is increased when turn the crank counter-clockwise. After that, tighten the clamping screw.

6.7 Adjusting the lift amount of the presser foot together with the walking foot.

The lift amount of the walking presser foot together with the presser foot also can be adjusted slightly. When adjusting, loosen the nut with a spanner first, then move the presser foot lift regulating screw to change its center distance B between the presser foot lift shaft, as shown in Fig.37. The lift amount is increased to shorten center distance B, and the lift amount is decreased to widen center distance B. After adjustment, tighten the nut again.

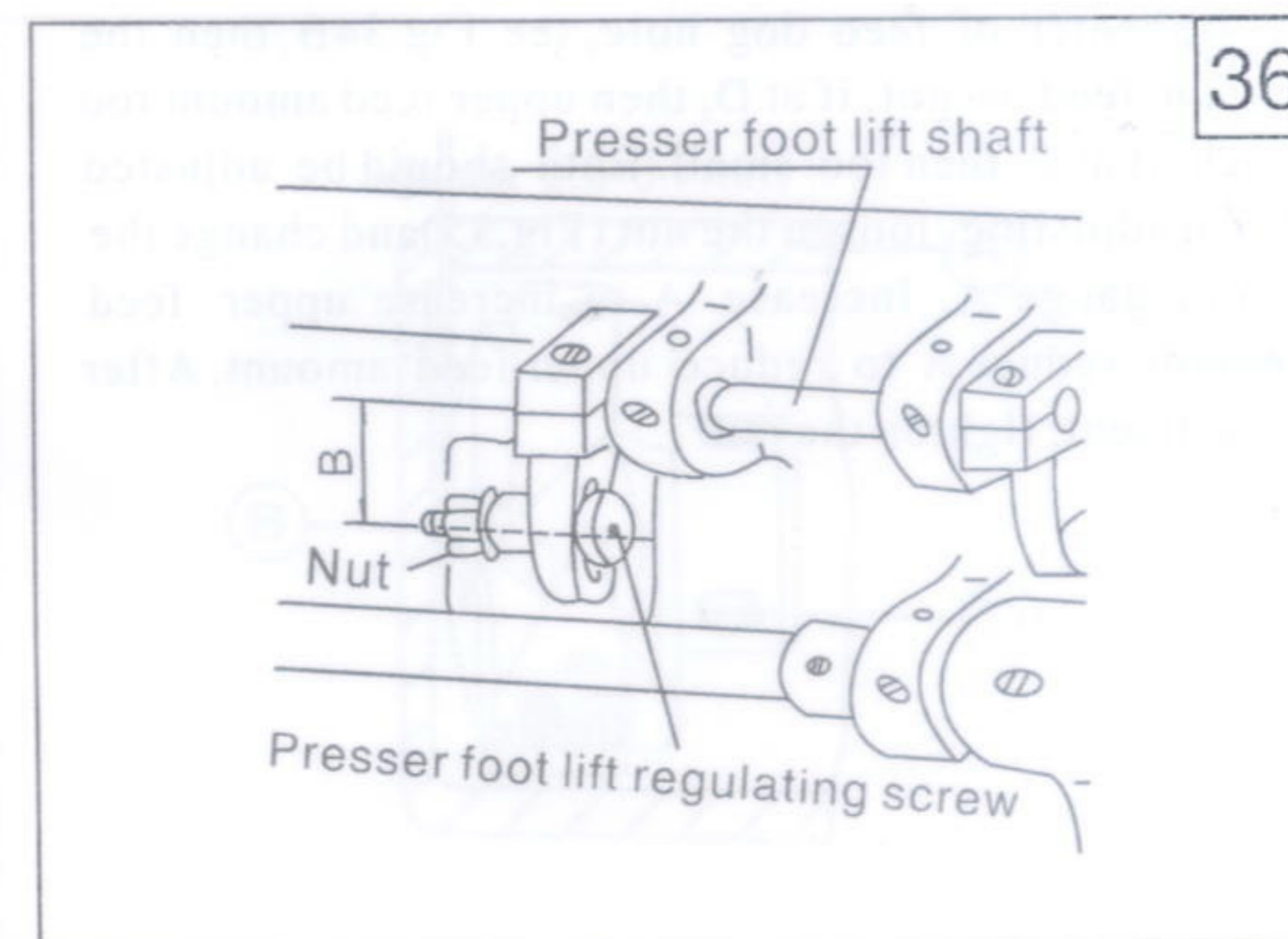
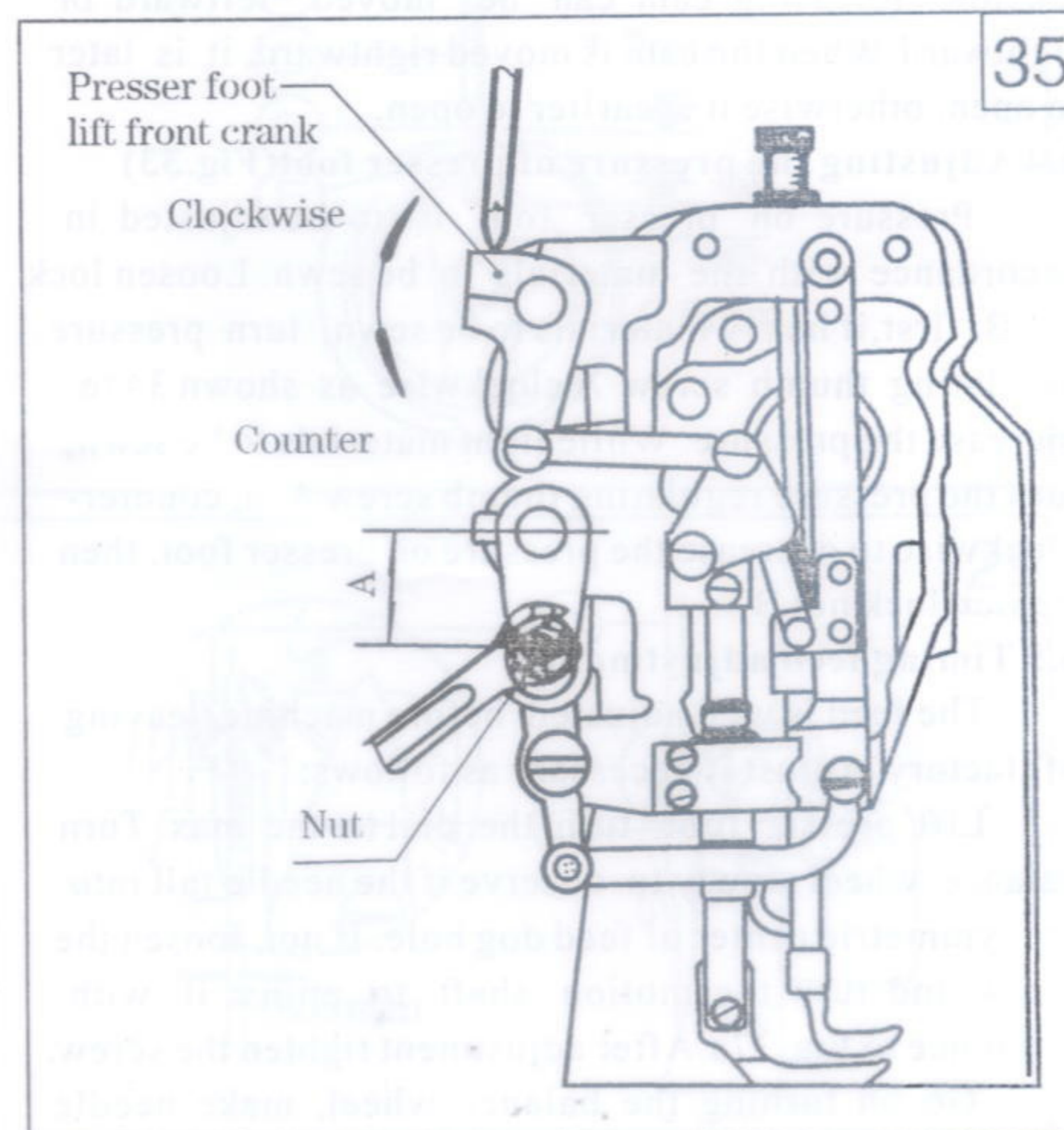
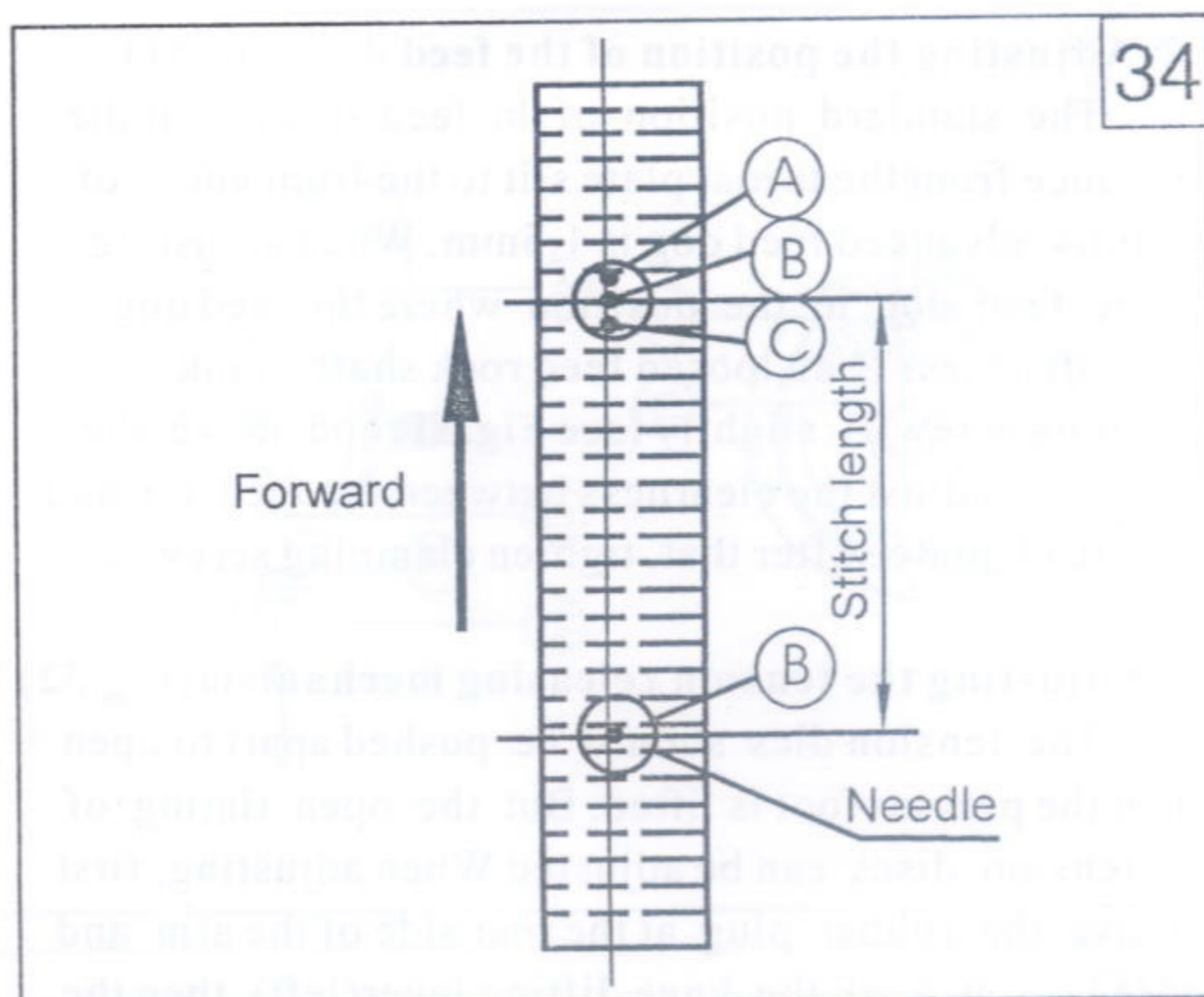

6.8 Adjusting the clearness between the presser foot and the walking presser foot (Fig.37)

In sewing, to prevent the walking presser foot from striking on the presser foot at the end of feeding, a proper clearness C of approx.15mm should be kept between them, as shown in Fig.37b. When the clearness is too small or too big and it is necessary to be adjusted, loosen the rear crank clamping screw with a screw driver and turn the rock shaft, as shown in Fig.37a. Turn the rock shaft clockwise to decrease clearness C , and turn the rock shaft counter-clockwise to increase clearness C . After adjustment, tighten the clamping screw.

During adjusting presser foot, if needle is off the symmetric center of feed dog hole, then loosen the screw D for feed dog (see Fig.37c) and adjust the position of feed dog. After finishing, tighten screw D .

After the adjustment, an inspection should be made, as to raise the presser feet with presser bar lifter, and turn balance wheel slowly to see if the walking presser foot is to strike with other parts. if it is, should be adjusted again.

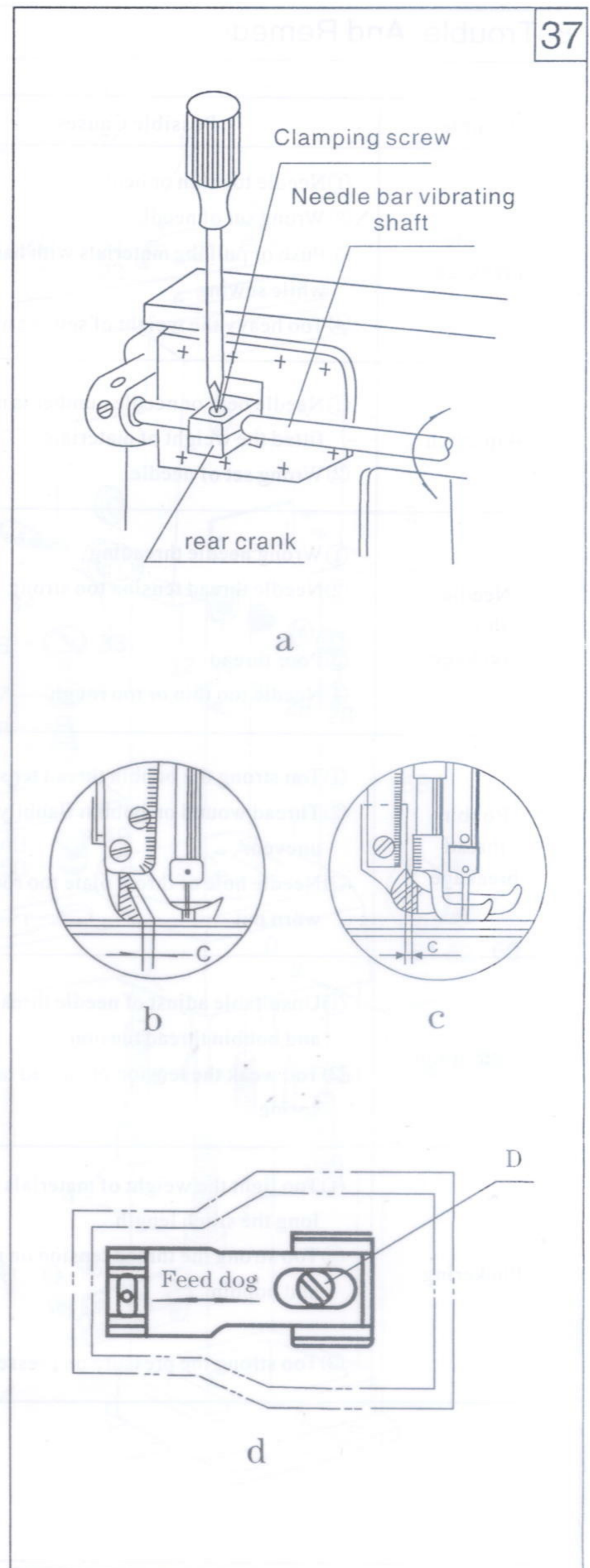

7. Periodical cleaning

Clean the feed dog, the rotating hook, the bobbin case and the like periodically according to customer's usage.

Remove the throat plate, the slide ring and the bobbin case and clean off all the dust and lint on the slit of the feed dog and on the rotating hook and wipe them with brush.

8. Trouble And Remedy

Trouble	Possible Causes	Remedy
Needle breakage	<ul style="list-style-type: none"> ① Needle too thin or bent. ② Wrong set of needle. ③ Push or pull the materials with hand while sewing ④ Too heavy the weight of sewing materials. 	<p>Change the needle with a new one. Refer to Fig 13 on Page 5</p> <p>Support the materials gently with hand while sewing</p> <p>Use the needle according to the technical specifications.</p>
Skip stitch	<ul style="list-style-type: none"> ① Needle bent or needle number is not fitted the weight of materials. ② Wrong set of needle. 	<ul style="list-style-type: none"> ① Chang the needle. ② Refer to Fig 13 on Page 5.
Needle thread breakage	<ul style="list-style-type: none"> ① Wrong needle threading ② Needle thread tension too strong ③ Poor thread ④ Needle too thin or too rough 	<ul style="list-style-type: none"> ① Refer to Fig 16 on Page 6. ② Befer to Fig 25 on Page 8. decrease the tension on the needle thread ③ Change the thread ④ Change the needle.
Bobbin thread breakage	<ul style="list-style-type: none"> ① Too strong the bobbin thread tension ② Thread wound on bobbin flabbily and uneven. ③ Needle hole of throat plate too rough or worn out 	<ul style="list-style-type: none"> ① Weaken the bobbin thread tension. ② Wind the bobbin again. ③ Change the throat or polish needle hole with#Oemery cloth.
Loose stitch	<ul style="list-style-type: none"> ① Unsuitable adjust of needle thread tension and bobbin thread tension ② Too weak the tension on thread take-up spring 	<ul style="list-style-type: none"> ① Readjust the needle thread tension and bobbin thread tension ② Adjust thread take-up spring as per Fig 22 on Page 7.
Puckering	<ul style="list-style-type: none"> ① Too light the weight of materials and too long the stitch length. ② Too strong the thread tension on needle and bobbin. ③ Too strong the pressure on presser foot. 	<ul style="list-style-type: none"> ① Adjust suitably. ② Adjust tension regulation thumb nut, thread take-up spring and bobbin case tension spring screw. ③ Loosen pressure regulating thumb screw.



Parts catalog Contents

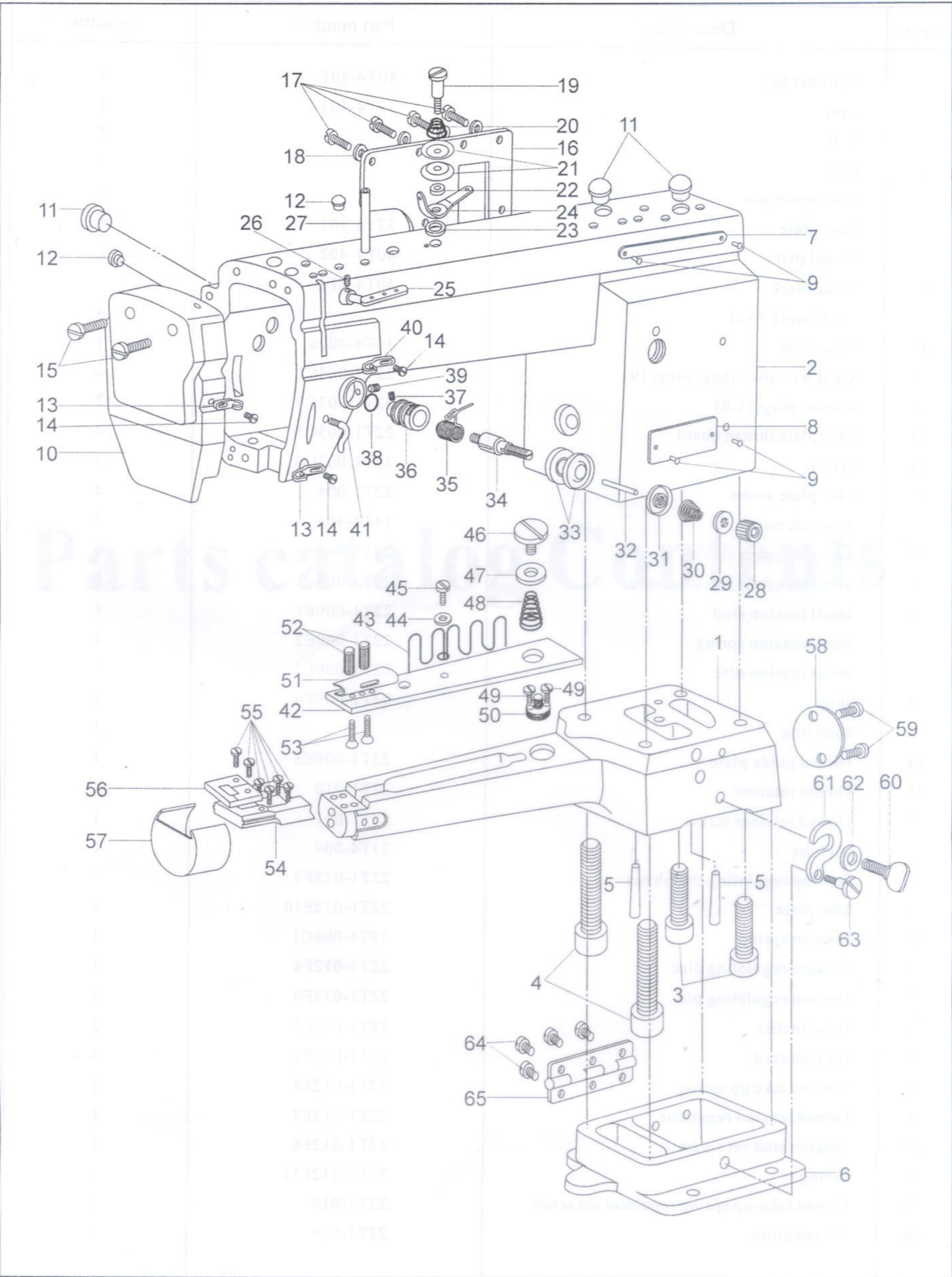

1、 Arm and bed

Item	Description	Part number	Quantity
1	Cylinder bed	40T4-401	1
2	Arm	37T4-403	1
3	Bolt		2
4	Bolt		2
5	Arm dowel pin		2
6	Base plate	37T4-401	1
7	Model plate	40T4-402	1
8	Trade mark	40T4-414	1
9	Trade mark rivet		4
10	Face plate	35T4-402a	1
11	Sight window rubber plug(19)	22T1-003C3	3
12	Rubber plug(11.8)	22T1-003C4	2
13	Face plate thread guard	22T1-003C5	2
14	Screw	22T1-003C6	3
15	Face plate screw	22T1-004	2
16	Arm side cover	34T4-405	1
17	Arm side cover screw	22T1-006	6
18	Arm side cover screw washer	22T1-007	6
19	Small tension stud	22T1-009E1	1
20	Small tension spring	22T1-009E2	1
21	Small tension disc	22T1-009E3	2
22	Shim	22T1-009E4	1
23	Snap ring		1
24	Thread guide plate	22T1-009E5	1
25	Thread retainer	22T1-010	1
26	Thread retainer screw	22T1-011	1
27	Oil tube	33T4-004	1
28	Tension regulating thumb nut	22T1-012F2	1
29	Stop plate	22T1-012F10	1
30	Tension spring	33T4-008C1	1
31	Tension regulating disc	22T1-012F4	1
32	Tension regulating pin	22T1-012F9	1
33	Tension disc	22T1-012F5	2
34	Tension stud	22T1-012F1	1
35	Tension take up spring	22T1-012F6	1
36	Thread tension regulator	22T1-012F7	1
37	Tension stud set screw	22T1-012F8	1
38	O-ring	22T1-012F11	1
39	Thread take-up spring regulator set screw	22T1-013	1
40	Thread guide	22T1-014	1

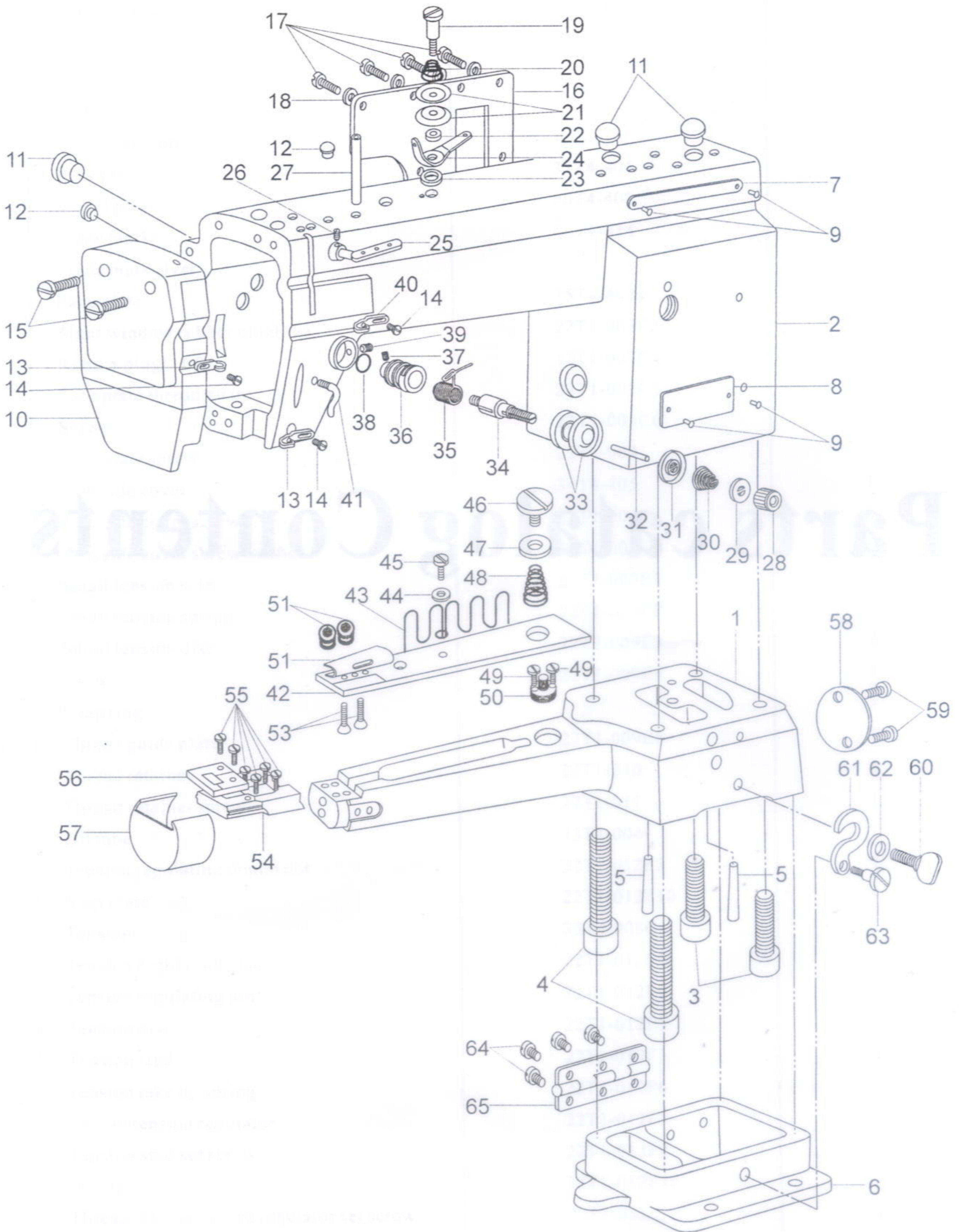

Item	Description	Part number	Quantity
41	Thread guide	35T4-405	1
42	Cylinder cover plate	40T4-404	1
43	Binding tape frame	40T4-405	1
44	Washer	22T1-007	1
45	Screw	22T1-006	1
46	Screw	40T2-206	1
47	Spring spacer	40T2-207	1
48	Coil spring	40T2-211	1
49	Screw	40T2-210	2
50	Feed dog support set shaft complete	40T2-209	1
51	Edge folder complete	40T4-406	1
52	Nut	40T4-409	2
53	Screw		2
54	Hook positioner bracket	40T4-410	1
55	Screw	40T4-411	6
56	Throat plate	40T4-412	1
57	Sliding plate	37T4-421	1
58	Cylinder cover plate	37T4-422	1
59	Screw	37T4-416	1
60	Screw	37T4-410	1
61	Connecting finger	37T4-409	1
62	Shim	37T4-411	1
63	Screw	37T4-412	1
64	Screw	37T4-408	6
65	Hinge	37T4-407	1

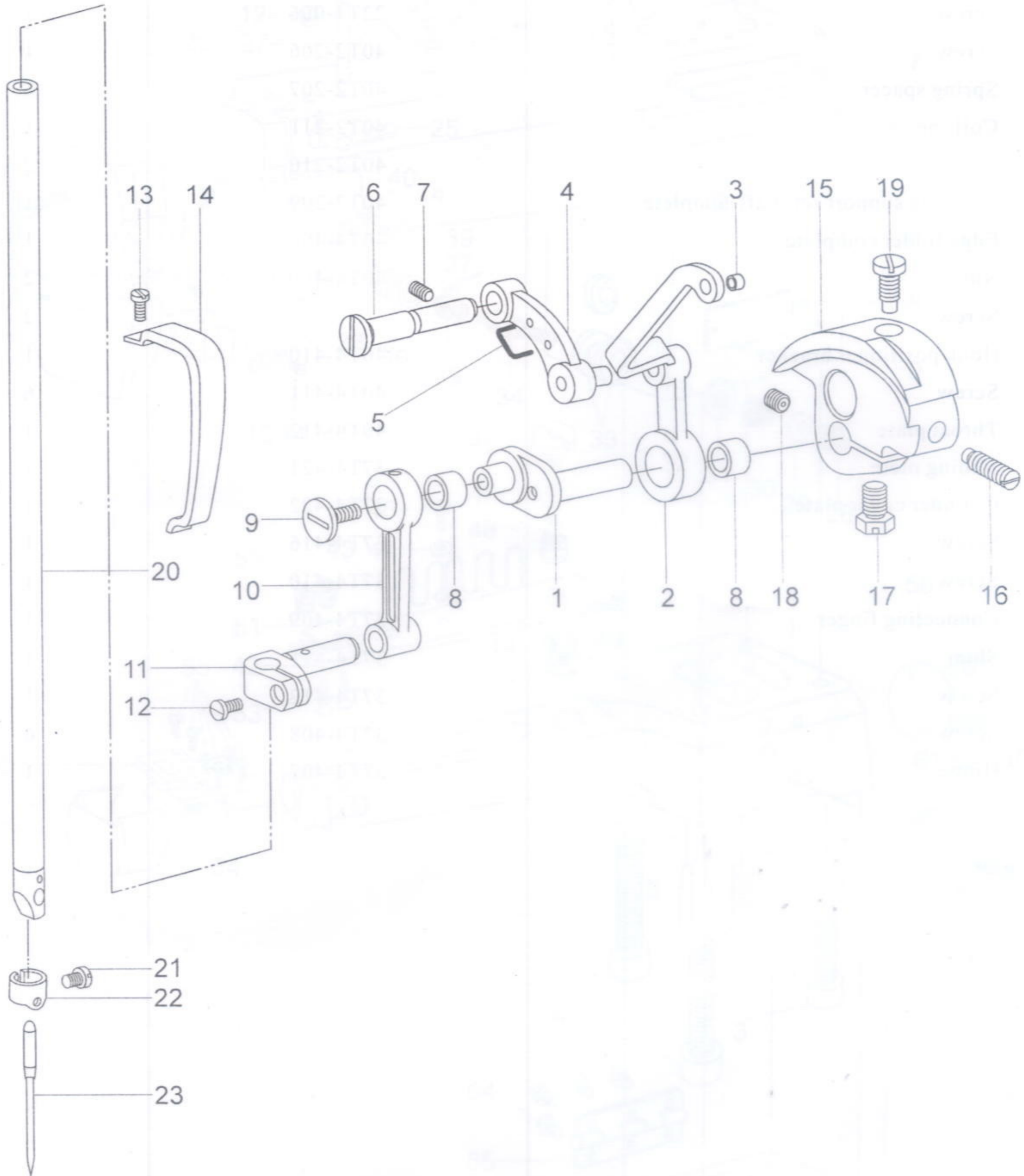

2、 Needle Bar And Thread Take-up

Item	Description	Part number	Quantity
1	Thread take-up crank	33T1-001	1
2	Thread take-up lever	33T1-004B1	1
3	Thread take-up lever eyelet bushing	33T1-004B2	1
4	Thread take-up link	33T1-003A1	1
5	Thread take-up link oil wick	33T1-003A2	1
6	Thread take-up link hinge pin	33T1-002	1
7	Thread take-up link hinge pin set screw	J0.0.40	1
8	Needle bearing	19242/8	2
9	Needle bar connecting link cap screw(left rotation)	22T2-001A6	1
10	Needle bar connecting link	33T1-014	1
11	Needle bar connecting stud	130032	1
12	Needle bar connecting stud clamping screw	22T2-001A9	1
13	Thread take-up lever guard	33T1-007	1
14	Thread take-up lever guard screw	33T2-004	1
15	Needle bar crank	33T1-006C1	1
16	Needle bar crank set screw	33T1-006C2	1
17	Thread take-up crank clamping screw	33T1-006C3	1
18	Thread take-up crank position screw	22T2-005B3	1
19	Needle bar crank clamping screw	61-04-01/B2	1
20	Needle bar	33T1-017	1
21	Needle bar thread guide	22T2-015	1
22	Needle		1
23	Needle set screw	22T2-017	1

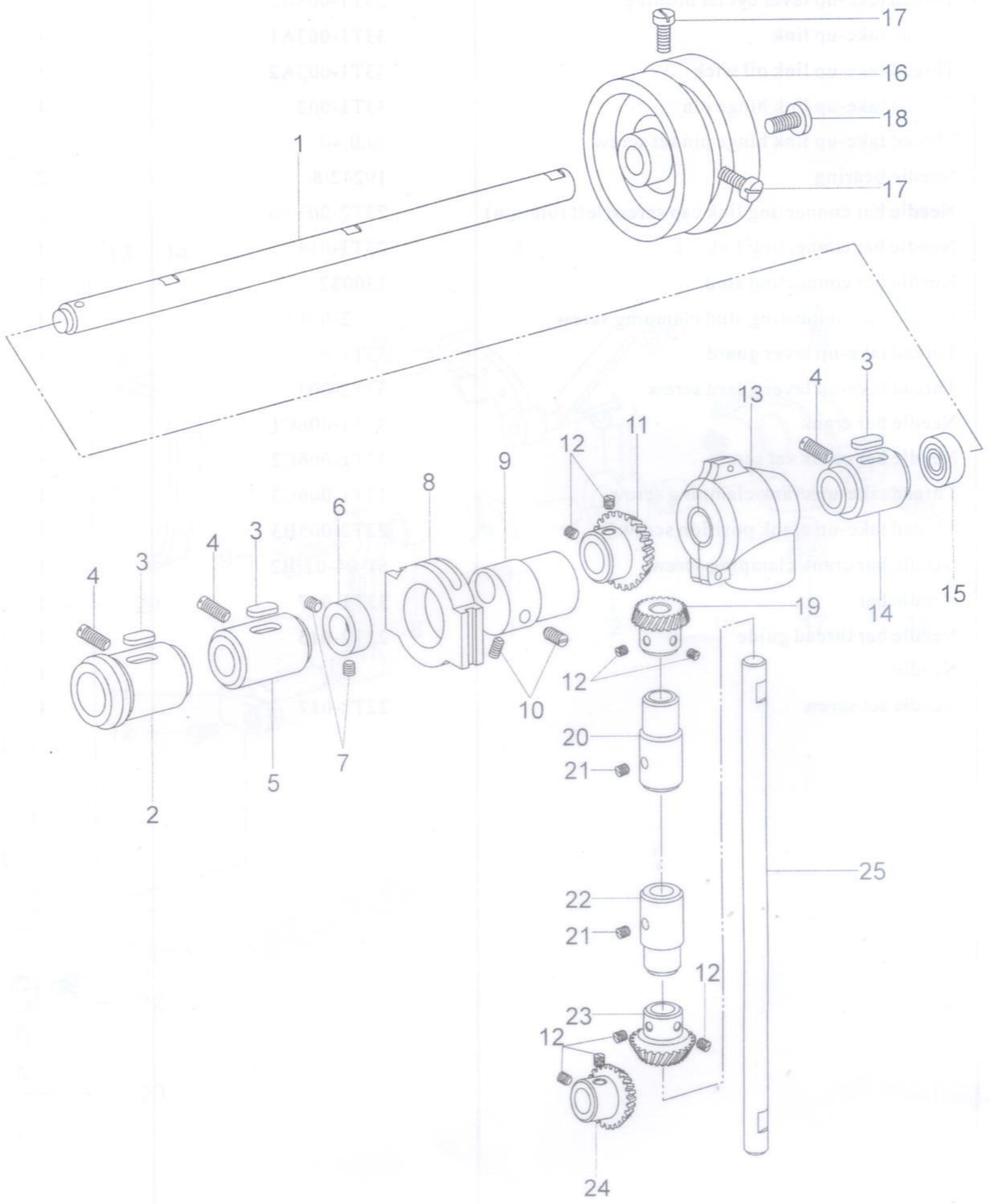

3、 Arm Shaft And Vertical Shaft

Item	Description	Part number	Quantity
1	Arm shaft	33T1-008	1
2	Arm shaft flanged bushing (front)	33T1-007D1	1
3	Arm shaft bushing oil felt	33T1-007D2	3
4	Arm shaft bushing set screw	J0.0.40	3
5	Arm shaft bushing (middle)	33T1-009E1	1
6	Collar	22T3-002B1	1
7	Collar set screw	22T3-003B2	2
8	Feed and feed lifting eccentric sleeve complete	22T3-009D1a2	1
9	Feed and feed lifting eccentric	40T2-214	1
10	Screw	22T1-013	2
11	Arm shaft bevel gear	22T3-010E2a1-2	1
12	Bevel gear screw	22T2-005B3	8
13	Bevel gear case(upper)complete	33T1-010F	1
14	Arm shaft bushing(rear)	33T1-011G1	1
15	Arm shaft bushing(rear)oil seal complete	22T3-006F	1
16	Balance wheel	33T1-024	1
17	Screw for balance wheel	22T3-007C2	2
18	Screw for arm shaft	22T3-008	1
19	Vertical shaft bevel gear(upper)	22T3-010E2a2-2	1
20	Vertical shaft bushing(upper)	33T1-025Q	1
21	Vertical shaft bushing screw	J0.0.40	2
22	Vertical shaft bushing(lower)	33T1-023P1	1
23	Vertical shaft bevel gear(lower)	22T3-010E2b2-2	1
24	Rotating hook shaft bevel gear	22T3-010E2b1-2	1
25	Vertical shaft	33T1-026	1

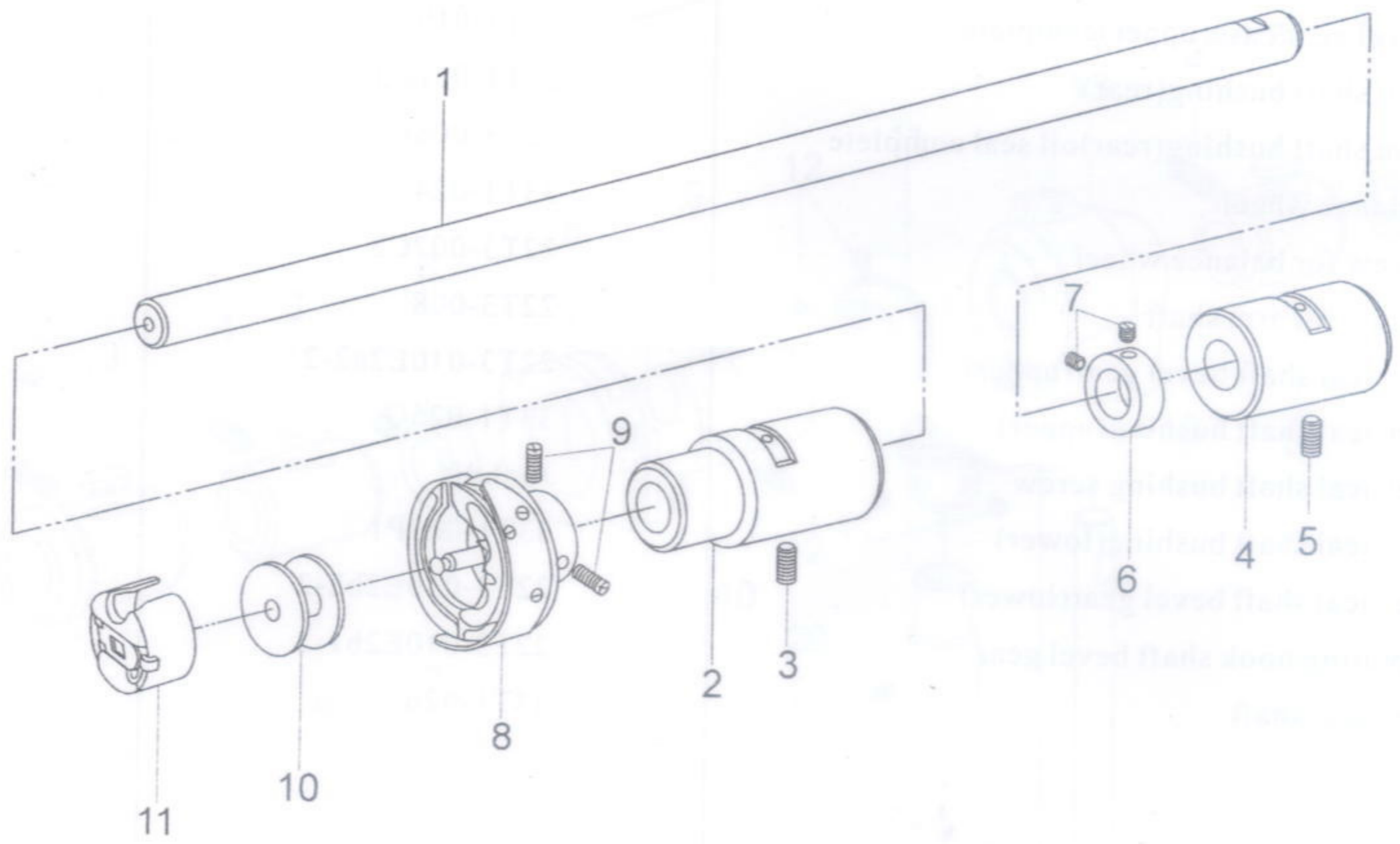

4、Rotating Hook And Its Oscillating shaft

Item	Description	Part number	Quantity
1	Rotating hook shaft assembly	33T1-021L	1
2	Rotating hook shaft bushing(front)	40T1-101	1
3	Rotating hook shaft bushing(front)screw	J0.0.40	1
4	Rotating hook shaft bushing(rear)	37T1-103	1
5	Rotating hook shaft bushing(rear)screw	J0.0.81	1
6	Rotating hook shaft collar	37T1-102	1
7	Rotating hook shaft collar set screw	22T2-013	2
8	Rotating hook assembly	37T1-104	1
9	Rotating hook set screw	37T4-105	3
10	Bobbin	33T1-027	1
11	Bobbin case assembly	33T1-028R	1

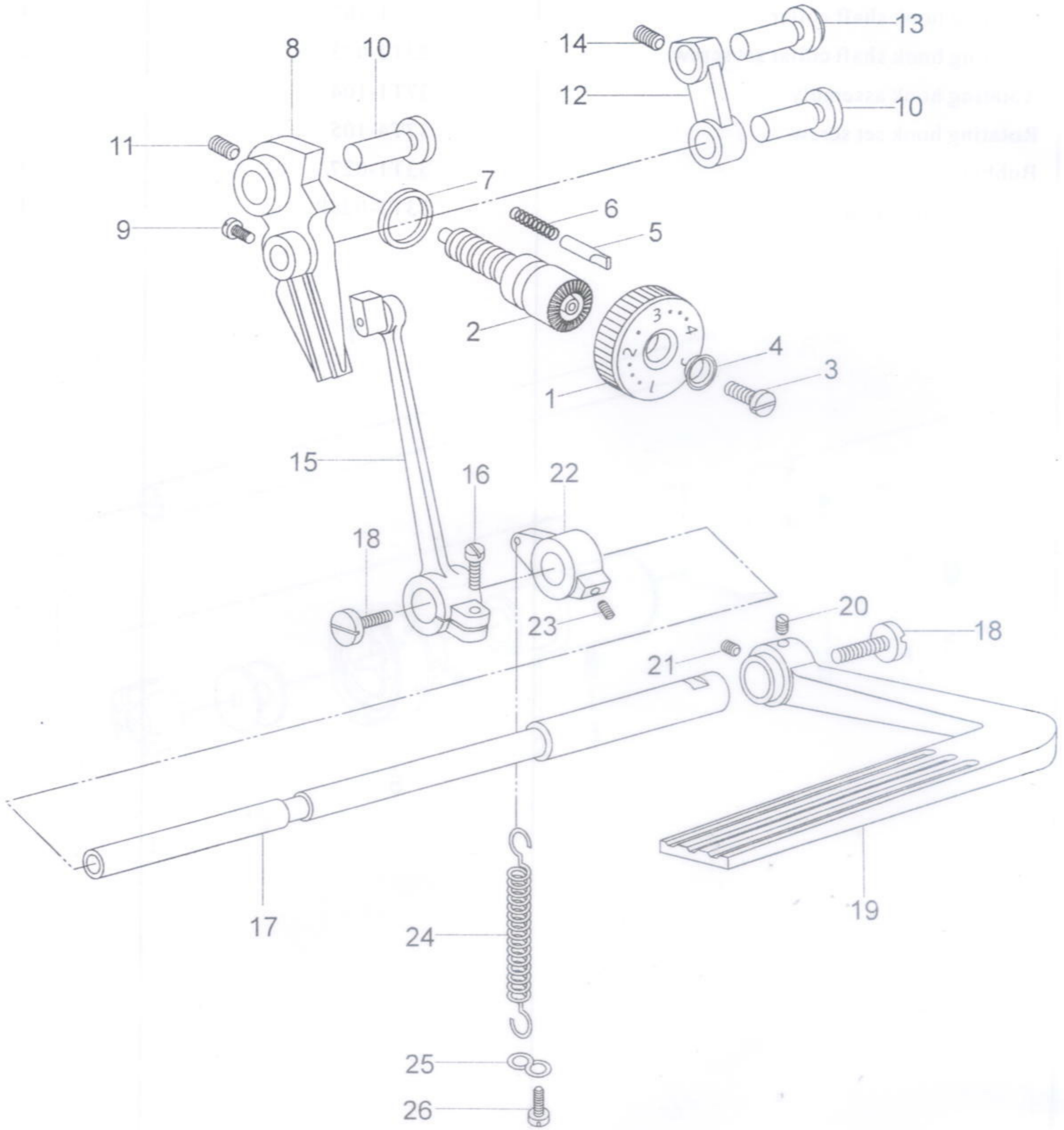

5、Stitch Length Regulating

Item	Description	Part number	Quantity
1	Stitch length dial	33T2-012	1
2	Stitch length adjusting screw	33T2-009	1
3	Screw	22T5-006C3	1
4	Screw bushing	36T5-007D4	1
5	Stop pin	22T5-008	1
6	Spring	22T5-009	1
7	O-type ring		1
8	Stitch length adjusting swing bar	33T2-013-A	2
9	Set screw	17T5-010	1
10	Hinge pin	33T2-024-A	1
11	Stitch	J0.0.81	1
12	Stitch length link	33T2-025-A	1
13	Connecting pin	33T2-026-A	1
14	Set screw	22T2-005B3	1
15	Reverse feed swing lever complete	33T2-019C	1
16	Screw	22T6-001A1b	1
17	Reverse lever shaft	37T2-020	1
18	Screw	17T5-019	2
19	Reverse feed lever	17T5-015	1
20	Set screw	17T5-017	1
21	Screw	17T5-016	1
22	Reset lever	33T2-021	1
23	Screw	6A6-08A	1
24	Coil spring	33T2-022	1
25	Set hook for spring	33T2-023	1
26	Screw	22T1-006	1

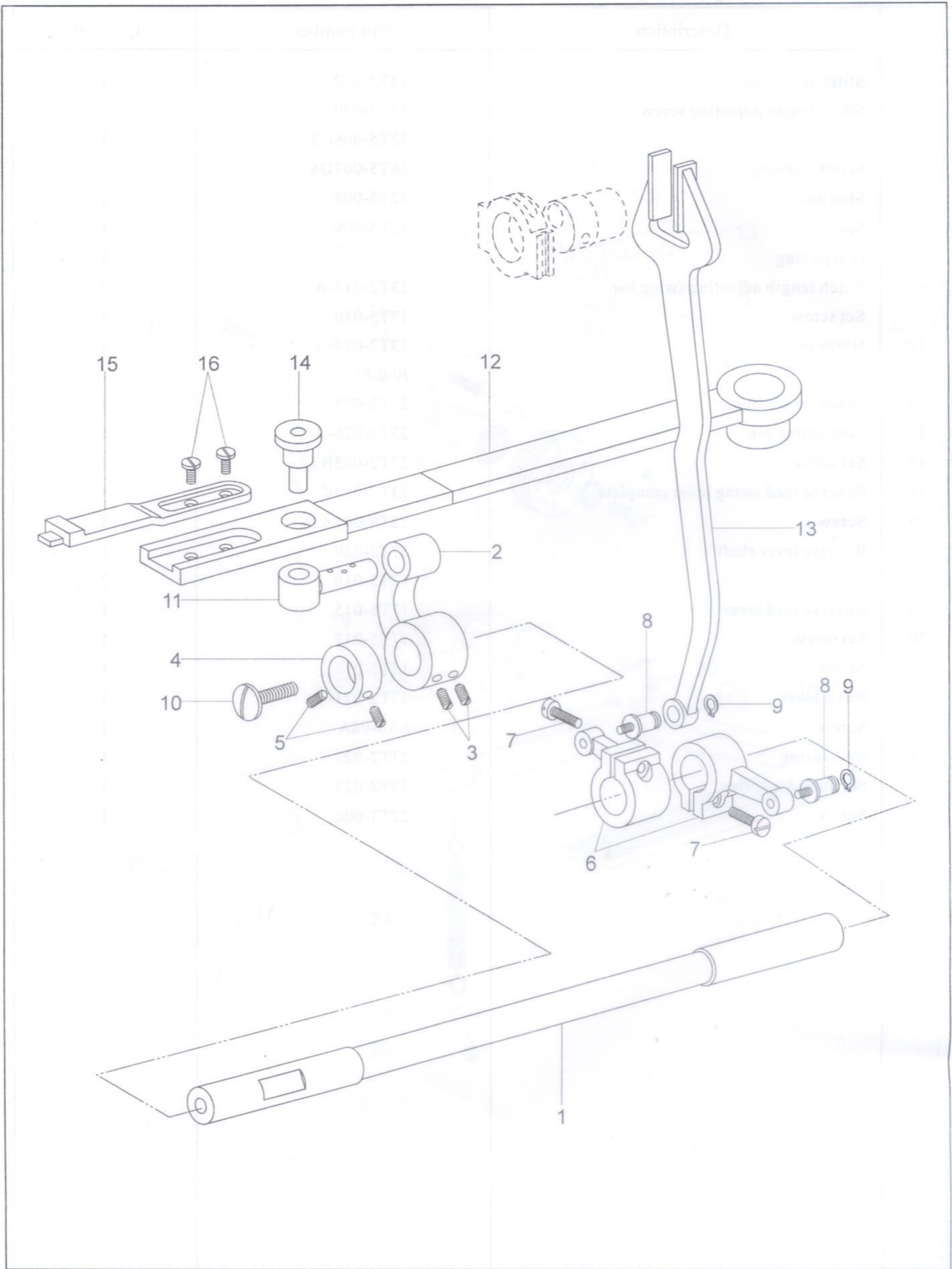

6、Bottom Feed

Item	Description	Part number	Quantity
1	Feed shaft	40T2-205	1
2	Front crank	40T2-213	1
3	Screw	22T1-011	2
4	Feed rock shaft and feed lifing rock shaft collar	37T2-208	1
5	Screw	22T2-013	2
6	Feed crank	37T2-212	2
7	Feed rock shaft crank set screw	37T2-210	2
8	Link connecting stud	37T2-213	2
9	Link connecting stud snap ring		2
10	Screw	17T5-019	1
11	Feed linking rock shaft	40T2-204	1
12	Feed dog support	40T2-212	1
13	Feed fork	37T2-214	1
14	Feed shaft pin	40T2-203	1
15	Feed dog	40T2-201	1
16	Screw	40T2-202	2

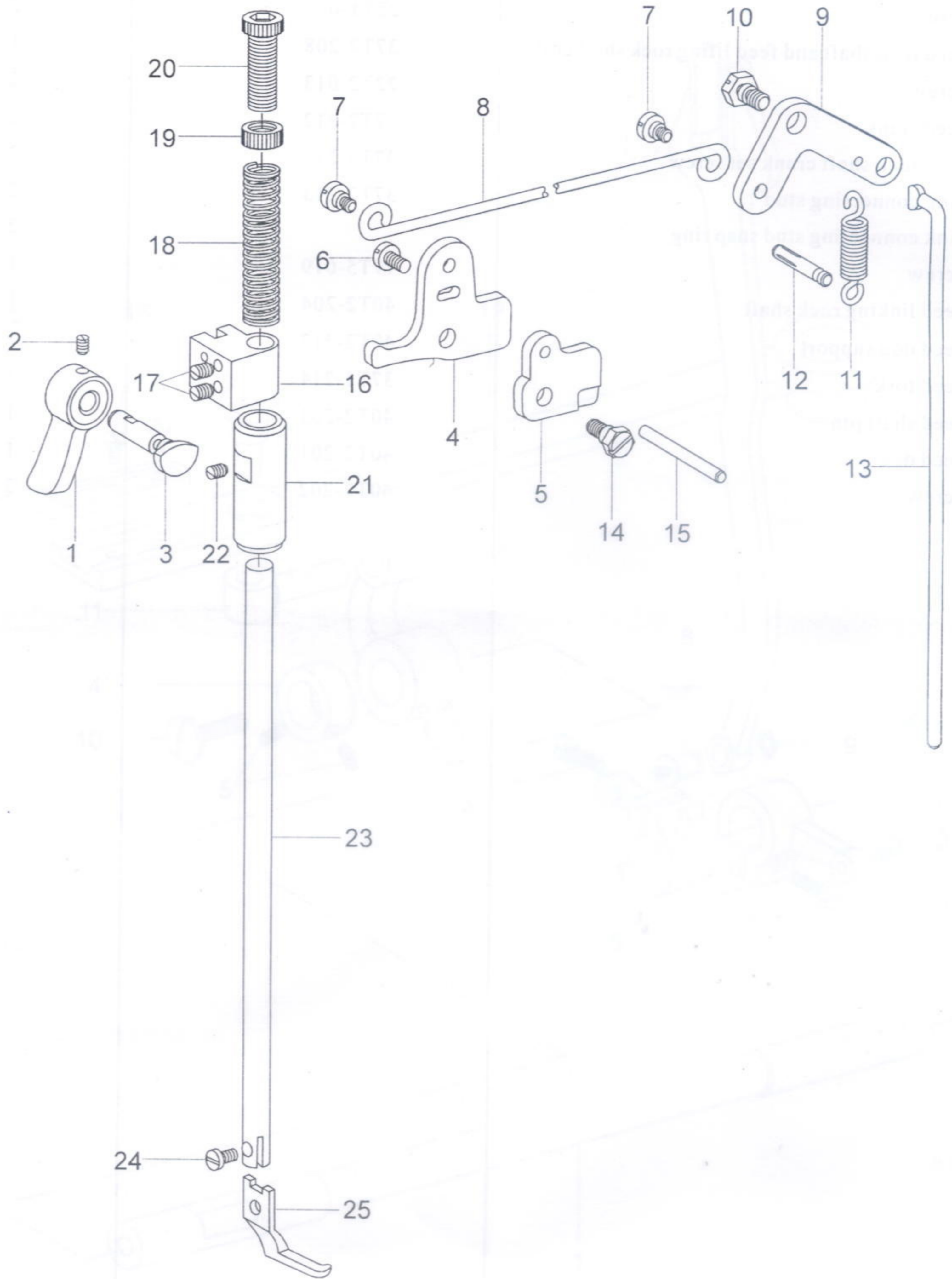

7、Presser Bar And Drawing Bar

Item	Description	Part number	Quantity
1	Presser bar lifter	334T3-304	1
2	Presser bar lifter position screw	22T7-001A2	1
3	Presser bar lifting cam	33T3-004	1
4	Knee lifter bellcrank(left)	22T7-004B1a	1
5	Tension releasing cam	22T7-004B1b	1
6	Knee lifter bellcrank (left) screw	22T7-004B1c	1
7	Screw for knee lifter bellcrank hinge	22T7-004B2	2
8	Knee lifter drawing bar	22T7-004B3	1
9	Knee lifter bellcrank(right)	22T7-007C1	1
10	Knee lifter bellcrank(right)screw	22T7-005(B)	1
11	Knee lifter bellcrank(right) spring	22T7-007C2	1
12	Spring connecting pin for knee lifter bellcrank(right)	22T7-008	1
13	Knee lifter connecting rod	37T3-301	1
14	Tension releasing cam screw	22T7-005(A)	1
15	Tension releasing rod	35T3-305	1
16	Presser bar position block	35T3-301	1
17	Presser bar position block screw	J0.0.40	2
18	Presser bar spring	34T3-302	1
19	Presser regulating thumb screw lock nut	22T7-014E2	1
20	Presser regulating thumb screw	34T3-301	1
21	Presser bar bushing	35T3-303	1
22	Presser bar bushing screw	22T2-013	1
23	Presser bar	35T3-302	1
24	Presser foot screw	22T2-019	1
25	Presser foot	40T3-301	1

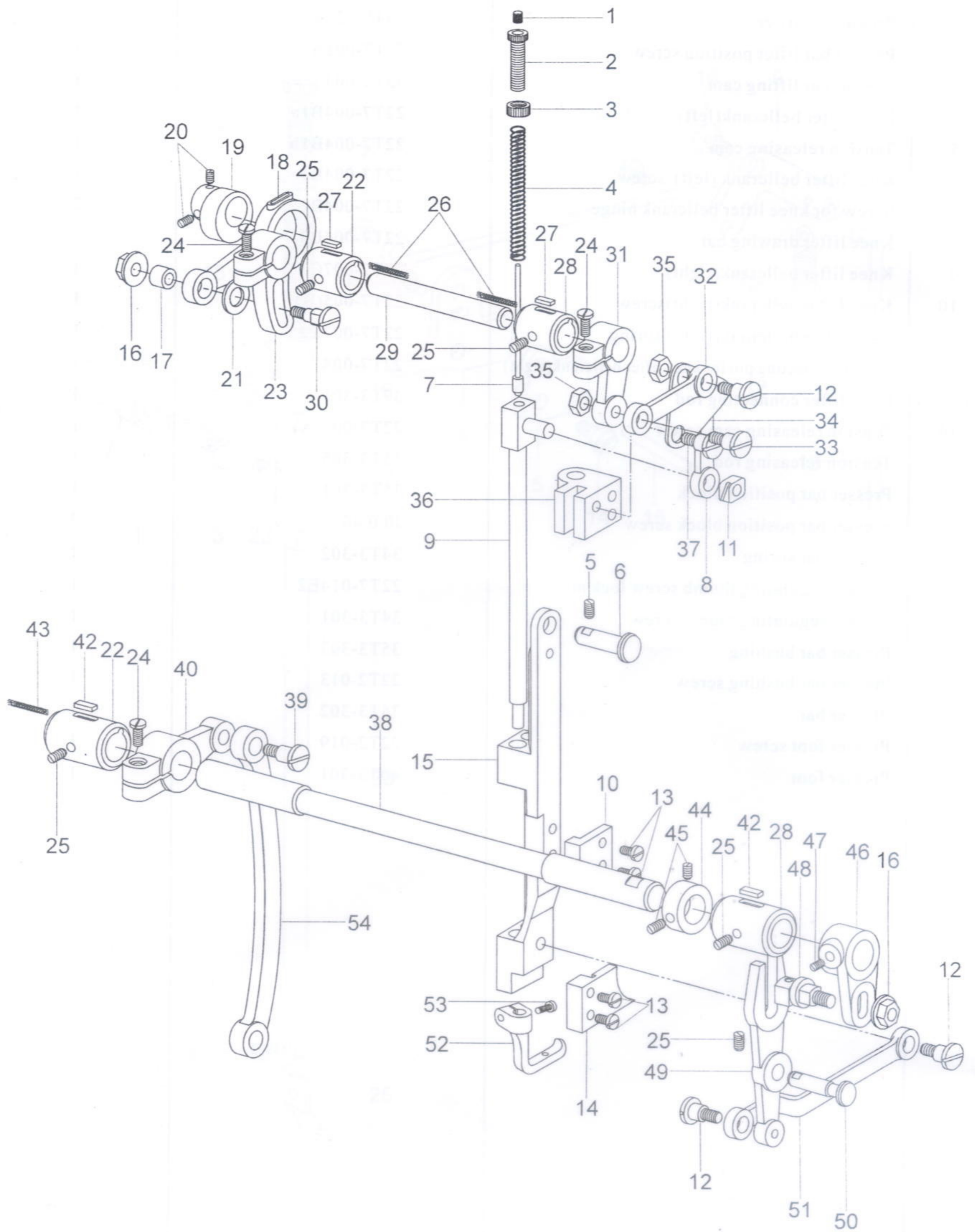

8、Top Feed

Item	Description	Part number	Quantity
1	Oil felt	34T5-501	1
2	Screw	35T5-503	1
3	Nut	34T5-503	1
4	Press bar spring	35T5-501	1
5	Screw	J0.0.40	1
6	Needle bar move stand shaft	35T5-504	1
7	Spring bar	35T5-505	1
8	Presser foot up and down link	35T5-507	1
9	Connector	35T5-509	1
10	Slot for slide block	35T5-513	1
11	Slide block	33T1-013	1
12	Screw	34T5-507	3
13	Screw	22T2-019	4
14	Rail block	35T5-511	1
15	Needle bar move stand	35T5-510	1
16	Nut	34T5-531c	2
17	Washer	34T5-519	1
18	Link	34T5-520	1
19	Presser foot up and down eccentric	34T5-516	1
20	Screw	01/B602	2
21	Washer	34T5-521	1
22	Rear bushing	34T5-538a	2
23	Rear crank	34T5-517	1
24	Screw	34T5-540	3
25	Set screw	J0.0.35	5
26	Cotton wick	34T5-536c	2
27	Oil felt	34T5-536b	2
28	Front bushing	34T5-536a	2
29	Presser foot up and down shaft	34T5-537	1
30	Screw	34T5-522	1
31	Front crank	34T5-535	1
32	Link	34T5-534	1
33	Bolt	34T5-513b	1
34	Presser foot up and down lever	35T5-506	1
35	Nut	34T5-516	2
36	Presser bar set block	35T5-301	1
37	Bolt	34T5-527	1
38	Needle bar move shaft	34T5-539	1
39	Screw	17T4-002	1
40	Rear crank	34T5-523	1
41	Screw	61-04-01/B06	1
42	Felt	34T5-538b	2
43	Cotton wick	34T5-538c	2
44	Collar	34T5-532	1
45	Screw	22T3-002B2	2
46	Front crank for needle bar move	34T5-533	1
47	Screw	01/B902	1
48	Slide block complete	34T5-531	1
49	Fork bar	34T5-529	1
50	Pin	34T5-530	1
51	Needle bar move link	35T5-512	1
52	Small presser foot	40T5-502	1
53	Screw	22T2-001A9	1
54	Swing presser foot link	34T5-524	1

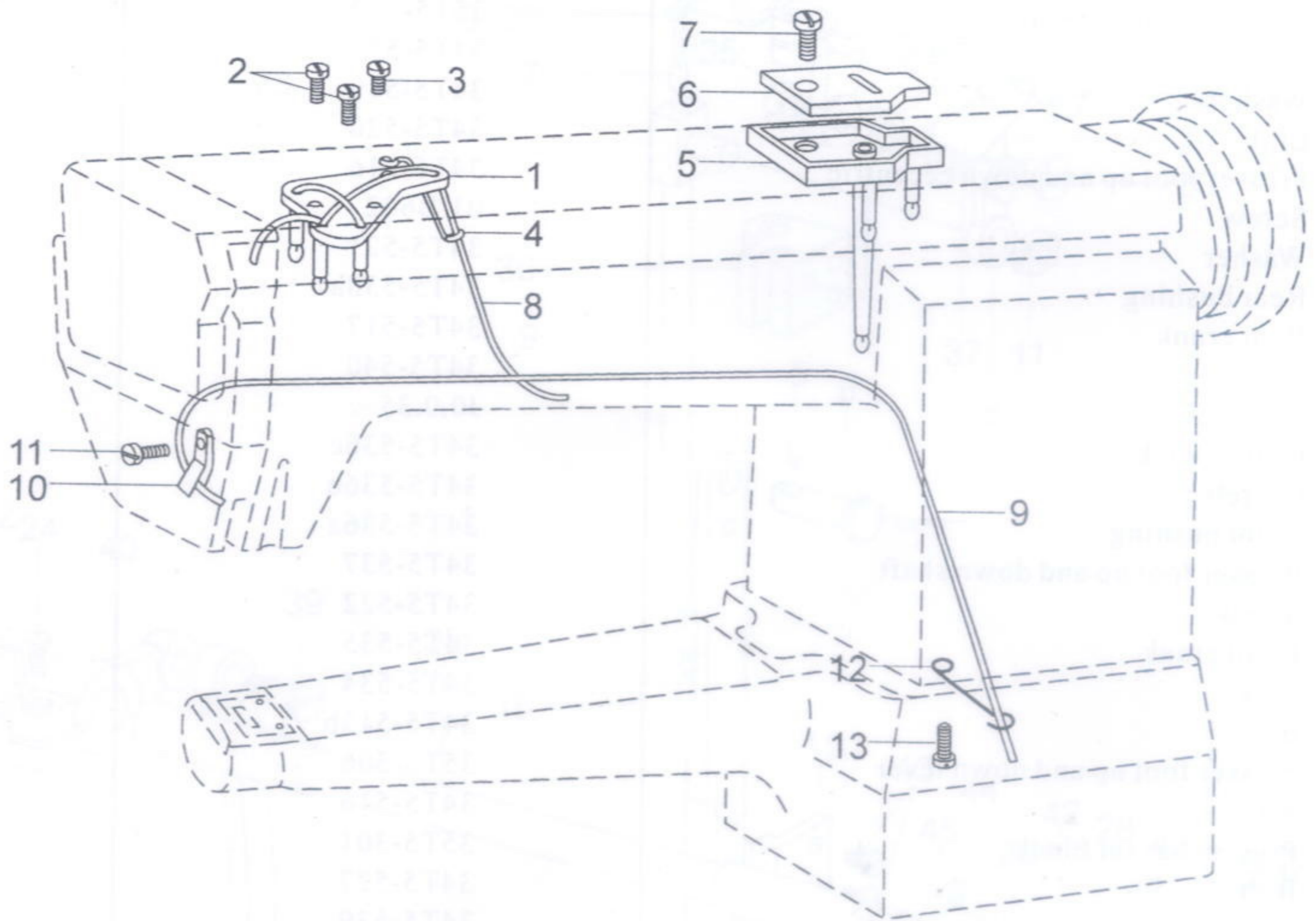

9、 Lubrication

Item	Description	Part number	Quantity
1	Oil wick fixing plate assembly	22T8-011C	1
2	Oil wick fixing plate screw	22T8-012	2
3	Oil wick fixing hook screw	22T8-011C4	1
4	Oil wick fixing hook	22T8-011C5	1
5	Small oil reservoir	33T4-005B1	1
6	Small oil reservoir oil pad	33T4-005B3	1
7	Small oil reservoir screw	33T4-005B2	1
8	Oil wick of oil wick fixing plate	22T8-011C3	1
9	Long oil wick		1
10	Long oil wick clamp	22T1-016	1
11	Long oil wick clamp screw	22T2-004	1
12	Long oil wick fixing hook	33T4-010	1
13	Long oil wick fixing hook screw	22T2-004	1

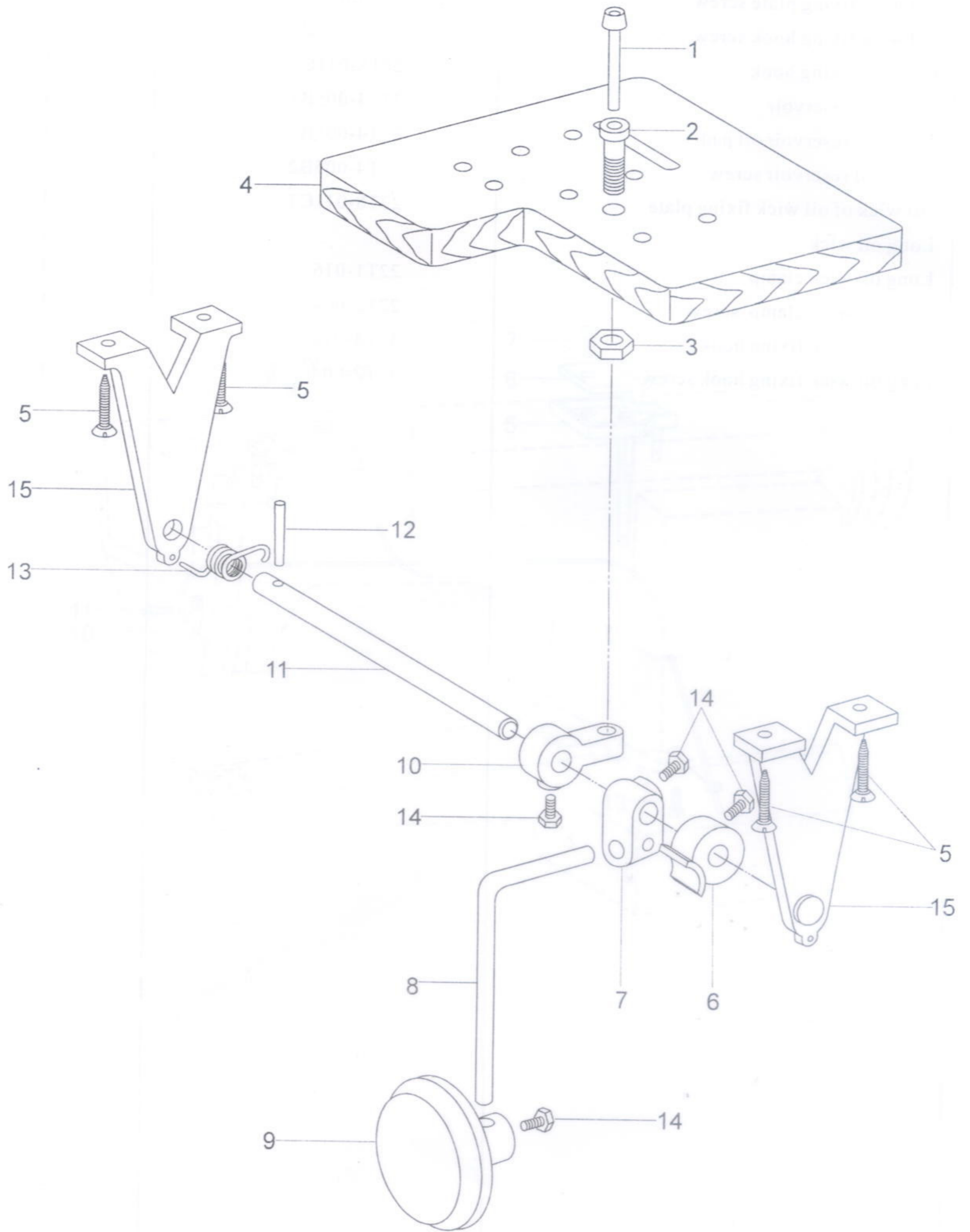

10、Knee Lifter

Item	Description	Part number	Quantity
1	Knee lifter pushing rod	37T6-601	1
2	Knee lifter pushing rod screw	37T6-602	1
3	Hexagon nut		1
4	Table	37T7-701	1
5	Round head wood screw		4
6	Knee lifter rock shaft stop dog	33T5-001E1	1
7	Knee lifter bellcrank joint	33T5-005	1
8	Knee lifter bellcrank	32T6-009	1
9	Knee lifter knee plate assembly	32T6-010F	1
10	Knee lifter lifting crank	33T5-002	1
11	Knee lifter rock shaft	33T5-007B1	1
12	Knee lifter rock shaft spring pin		1
13	Knee lifter rock shaft spring	33T5-006	1
14	Knee lifter knee plate set screw		4
15	Knee lifter rock shaft bracket	33T5-005	1

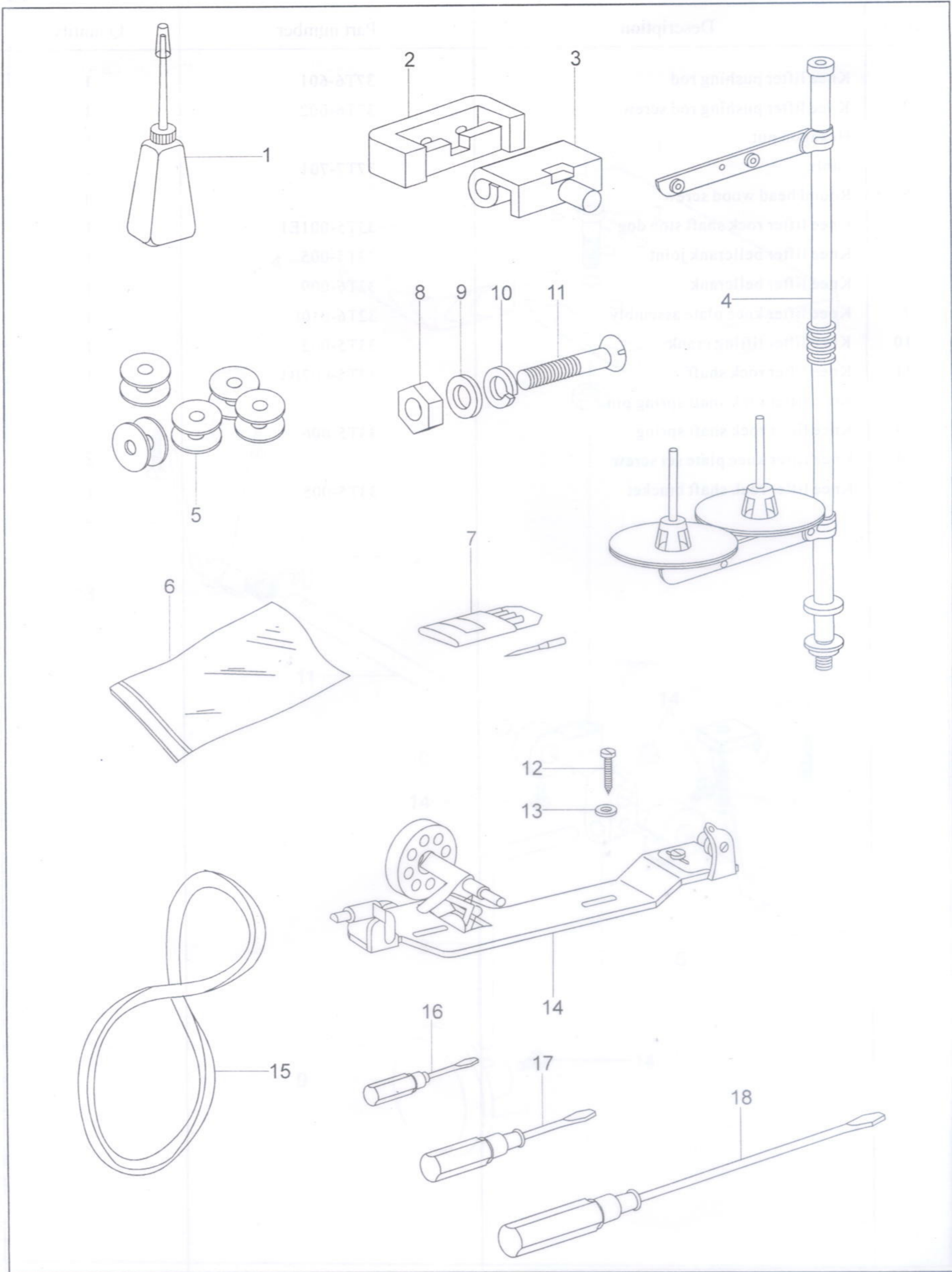

11、Accessories

Item	Description	Part number	Quantity
1	Small oil pot	33TF-011	1
2	Hinge case	33T7-003	1
3	Hinge hook	33T7-002	1
4	Spool stand complete	33TF-019	1
5	Bobbin case	33T1-027	1
6	Accessories bag	33TF-010	1
7	Needle	1F-009	1
8	Nut	37TF-007	4
9	Washer	37TF-008	4
10	Spring washer	37TF-009	4
11	Screw	37TF-006	4
12	Wood screw	33TF-017	2
13	Washer for woody screw	33TF-018	2
14	Bobbin winder complete	S14420020	1
15	V-belt	37TF-005	1
16	Screw driver(small)	33TF-014	1
17	Screw driver(middle)	33TF-013	1
18	Screw driver(big)	33TF-012	1

- Please don't adjust and repair the machine by non-professionals, except adjusting stitch.
- Specifications subject to change without notice

TYPICAL SEWING MACHINE WANPING MACHINERY CO.,LTD.

ADD: WANPING TOWN, WUJIANG CITY, JIANGSU
PROVINCE, CHINA

TEL: +86-512-63391278

FAX: +86-512-63391371

POST. CODE: 215223

[Http://www.typicalwpchina.com](http://www.typicalwpchina.com)

E-mail: export@typicalwpchina.com

Printed in May. 2008